



# ASIAN TRUCKER

www.asiantrucker.com

MALAYSIA

**FOTON DAIMLER**  
AUTOMOTIVE



**MPIRE**



4 YEARS  
UNLIMITED MILEAGE  
WARRANTY

**MPIRE COMMERCIAL SDN BHD** (1260072-T)

+603 5131 2255    info@mpiregroup.com.my

www.fotonmalaysia.com.my

No. 2, Jalan Gitar 33/3, Elite Industrial Park, Section 33, 40460 Shah Alam Selangor.







# HAMMAR

## THE ULTIMATE SIDELOADER

When you want the ultimate sideloader, there is only one choice- HAMMAR.

It can load and cart a 20', 2x20's, a 40', or even a jumbo 45' container in minutes at the push of a button.

Make **HAMMAR** your ultimate choice.

- Lightest tare weight in the world! From 2,000Kgs to 3,000Kgs lighter than the competition. Fuel savings with every kilometer covered!
- 1 tonne to 36 tonnes payload, same cycle time of 3.5 mins! Does not slow down when payload increases.
- 100% Spares always in stock.
- 24hrs back-up service, 365 days all year round.
- PTO or 84Hp Engine Power Pack options



**Hammar Maskin (M) Sdn Bhd**  
 41, Lebu Sultan Mohamed 1/KU18,  
 Taman Perindustrian Bandar Sultan Suleiman,  
 42000 Port Klang, Selangor D.E.Malaysia  
 Tel: +60-3-31790830 Fax: +60-3-31790831  
 E-mail info@hammar.com.my  
 Website www.hammar.com.my

**Hammar Maskin AB**  
 Buagärde 35, SE-517 95 OLSFORS,  
 Sweden  
 Tel: +46-33 290000 Fax: +46-33 290001  
 E-mail info@hammar.eu  
 Website www.hammar.eu

**Hammar Lift, Inc.**  
 300 25 Alicia Pkwy # 114 ,Laguna Niguel ,CA 92 677  
 Tel: +1 (949) 716-2513 Fax: +1 (949) 716-2514  
 Cell: (949) 293-0028  
 Email: info@hammarlift.com  
 Website www.hammarlift.com





**Hammar New Zealand Ltd**

PO Box 72-1347, Papakura 2244, 3 Glasgow Ave,  
 Manukau 2104, AUCKLAND, New Zealand  
 Tel: +64-9 488 99 80 Fax: +64-9 488 99 84  
 E-mail info@hammar.co.nz  
 Website www.hammar.co.nz

**Hammar Australia Pty Ltd**

PO Box W131, West Pennant Hills, SYDNEY,  
 NSW 2125, Australia  
 Tel: +61-2 4577 7700 Fax: +61-2 4577 7711  
 E-mail info@hammar.com.au  
 Website www.hammar.com.au



**NBG INDUSTRIES SDN BHD** (1052500-M)

No.133, Lot 7955, Jalan Sungai Buloh, Kampung Baru Subang,  
Seksyen U6, 40150 Shah Alam, Selangor.

Tel: +603-7859 9533 / +603-7859 8533 Fax: +603-7859 7833

Facebook: FAW Trucks Malaysia







**HINO 500 SERIES**

**BETTER PERKS,  
BETTER VALUE.**

**UNLIMITED  
MILEAGE\***



## **UNLIMITED MILEAGE AND 24 MONTHS WARRANTY**

**HINO TRUCK 500 SERIES POWER TRAIN \*1:**

Warranty period - **24 MONTHS / 200,000 KM**

**HINO TRUCK 500 SERIES OTHERS \*2:**

Warranty period - **12 MONTHS / UNLIMITED MILEAGE**

- This warranty will be expired at mileage or No. of month, whichever comes first.
- During this warranty period, customers are required to send their vehicle to Hino Motors Sales (Malaysia) Sdn Bhd workshop or any Hino Authorized Dealers for service at required service interval, failure to do so may result the warranty being null or void.



**HINO MOTORS SALES (MALAYSIA) SDN BHD** (187863-U)

**Selangor:** Lot PT. 24, Jalan 223, Section 51A, 46100 Petaling Jaya, Selangor Darul Ehsan, Malaysia. Tel: (603) 7957 5199 (12 lines) Fax: (603) 7954 3276 / 7957 2235

**Sarawak:** Lot 3477, Block 226 KNLD, Off Jalan Datuk Amar Kalong Ningkan, 93250 Kuching, Sarawak, Malaysia. Tel: (082) 451 611 (5 lines) Fax: (082) 451 993

**Sabah :** Mile 4 ½, Tuaran Road, Lot No. 353, Taman Cempaka, Likas, 88450 Kota Kinabalu, Sabah, Malaysia. Tel: (088) 393 663 Fax: (088) 424 223

**AUTHORISED DEALERS:** ■ **KUALA LUMPUR** • Daihatsu Malaysia (Kepong) 03-6276 6062, Hong Yep Motor (Batu Caves) 03-6186 3533 / 2522, ■ **SELANGOR** • Awesome Trucks Enterprise (Rawang) 03-6091 6212, Daihatsu Malaysia (Serdang Raya) 03-8943 7235, Daihatsu Malaysia (Shah Alam) 03-5510 9988, Eng Kee Commercial Vehicles (Klang) 03-3374 9278, Power Truck & Parts (Puchong) 03-8062 6882, Premium Truck (Semenyih) 03-8723 8833, Soo Chuan Motor Credit (Jln Kapar) 03-3370 1243, Soo Chuan Motor Credit (Klang) 03-3342 7918, Soon Heng Motor & Commercial Truck (Banting) 03-3341 7167, Soon Heng Motor & Commercial Truck (Kg Baru Subang) 03-7859 0326, ■ **PERAK** • Daihatsu Malaysia (Ipoh) 05-506 0331 / 907, SR Automobile Centre (Bidar) 05-434 6000, TTJ Agency (Taiping) 05-847 9368 / 012 400 9368, ■ **NEGERI SEMBILAN** • Soon Seng Truck & Parts (Nilai) 06-799 5975 / 5976, ■ **JOHOR** • Auto Skyline (Johor Bahru) 07-358 5805, Daihatsu Malaysia (Batu Pahat) 07-431 5910, Daihatsu Malaysia (Johor Bahru) 07-224 6601, Key Power (Pasir Gudang) 07-234 7228, Sam Hin Motors Enterprise (Kluang) 07-771 7410, Sam Hin Motors Enterprise (Segamat) 07-931 7939, Sin Soon Hup Services (Muar) 07-975 6688, Smart Edition Auto (Kulai) 07-663 2628, ■ **TERENGGANU** • Marsing Industries (Kuala Terengganu) 09-631 1022, ■ **KEDAH** • AWS Jaya Motors (Alor Setar) 04-731 9706, AWS Jaya Motors (Sg Petani) 04-423 1600, ■ **MELAKA** • Paramount Value (Taming Sari) 06-283 2925, Sam Hin

[www.hino.com.my](http://www.hino.com.my)





# 24 MONTHS\* WARRANTY

\* Terms and conditions apply.

#### Power Train\*<sup>1</sup>

For the purpose of this Warranty, "Power Train" means the following main functional parts of NEW HINO Vehicles (defined as below):

- I. Engine assembly, excluding, but not limited to, fuel filters, engine oil, alternator, air cleaner element, engine mountings, starter motor, radiator, v-belts, power steering pump and air conditioning if applicable,
- II. Clutch, excluding, but not limited to, clutch hydraulic actuating equipment and clutch disc,
- III. Transmission, excluding, but not limited to, gear oil and cleaner element, Propeller shaft universal joints and bearings and
- IV. Rear axle assembly, axles and wheel bearings, differential gear mechanism (crown wheel, pinion and bearings), excluding but not limited to, brake system, brake drums, wheel discs, tires, tire tubes and differential oil.

#### Others\*<sup>2</sup>

Excluding body and Power Train.

Visit our website for more information.



Motors Enterprise (Melaka) 06-232 1939, Sam Hin Motors Enterprise (Cheng) 06-337 6939. ■ PAHANG • Edaran Riz (Kuantan) 09-573 3377, Teck Lee Motor Agency (Temerloh) 09-296 1558 / 9558. ■ KELANTAN • K&T Engineering & Trading (Kota Bharu) 09-765 7166, K&T Engineering & Trading (Kota Bharu) 09-773 2522, Soon Seng Motors Enterprise (1988) (Kota Bharu) 09-748 6837. ■ PULAU PINANG • AWS Jaya Motors (Bayan Lepas) 04-646 3800, AWS Jaya Motors (Seberang Prai) 04-398 7600, Daihatsu Malaysia (Butterworth) 04-333 2151 / 04-323 4049, PM Trucks (Bukit Mertajam) 04-552 3762 / 3763, Sammir Motors Malaysia (Bukit Mertajam) 04-502 1458. ■ SABAH • Angkatan Hebat Motor (Kota Kinabalu) 088-437 278, Daihatsu Malaysia (Kota Kinabalu) 088-381 112, ATSB Tractors Parts (Tawau) 089-779 078, FF Automobile (Kota Kinabalu) 088-430 049, Weemaju Motor (Lahad Datu) 089-881 323, Weemaju Motor (Sandakan) 089-666 222. ■ SARAWAK • Jong Seng (Bintulu) 086-343 866, Jong Seng (Kuching) 082-330 066, Jong Seng (Mirii) 085-661 166, Jong Seng (Sibu) 084-334 166, Lu & Sons Engineering (Bintulu) 086-334 834, Lu & Sons Engineering (Kuching) 082-453 737, Lu & Sons Engineering (Sibu) 084-319 373, Rhino Automobile (Kuching) 082-349 587.

AIM FOR CUSTOMER TRUST AND CONFIDENCE

**GREATEST INVESTMENT EVER.**



**X3000**  
LONG-DISTANCE VEHICLES



**M3000**  
CITY AND URBAN VEHICLES

DISTRIBUTED BY  
**SHAANXI TRUCKS SDN BHD** (962614-K)  
MEMBER OF **YONMING** GROUP

CONTACT PERSON  
**Mr. Kau Chez Ching + 6012 282 2948 | +603 3166 3880**  
Lot 40778, Lorong Gerudi 1, Off Jalan Pelabuhan Utara, 42000 Port Klang, Selangor, Malaysia

**WWW.SHACMAN.COM.MY**



**YONMING**<sup>®</sup>

**COME JOIN US AT**

Largest South East Asia's Commercial Vehicles Expo

**20-22 June 2019 @ MIECC - Malaysia International Exhibition & Convention Centre**

**BOOTHS M09, M10, M17, A11-14, A21-25**





# Quality Parts

FOR EUROPEAN TRUCKS & BUSES



DISTRIBUTED BY  
**YONMING**<sup>®</sup>  
(716296-P)

☎ 603-6251 9448 🌐 [WWW.YONMING.COM](http://WWW.YONMING.COM)



**COME JOIN US AT**  
20-22 June 2019 @ **MIECC** - Malaysia International  
Exhibition & Convention Centre

**BOOTH**  
**M10**



# FOTON



## Foton Total Care

Backed by Tan Chong's Group service network



Vast Service  
Network

Distributor for Foton Trucks:



**ANGKA-TAN MOTOR SDN BHD** (85810-A)  
(A subsidiary of Warisan TC Holdings Berhad) 华丽山陈唱子公司

No. 117-119, Jalan SS15/5A, 47500 Subang Jaya, Selangor Darul Ehsan, Malaysia

Tel: 03-5638 6888 Tel: 03-5632 9668

Website: [www.angkatanmotor.com.my](http://www.angkatanmotor.com.my)



# TECHNOLOGY LEADING INTO THE *FUTURE*



**Driver  
Development  
Training**



**Provide  
Genuine Parts**



**24  
HOUR Breakdown  
Service**

**24/7 Breakdown  
Service**



**One-Stop Repair  
& Insurance  
Service**

**Master Dealer: TC Trucks Sales Sdn Bhd**

Batu Caves Tel:03-61891896 • Bukit Mertajam Tel: 04-5381308 • Ipoh Tel: 05-2921028 • Johor Bharu Tel: 07-3538808 • Klang Tel: 03-31669609 • Melacca Tel: 06-3366957 • Sabah Tel:088-499228 • Sarawak Tel:082-488811

**Authorized Dealers:**

Combine Motor Sdn Bhd Tel: 03-61363060 • Commercial Junction (M) Sdn Bhd Tel: 07-4333998 • Derchin Auto Sdn Bhd Tel: 07-3864108 • Edaran Setia Auto Sdn Bhd Tel: 09-5162288 • Element Autolink Tel: 03-77728363 • Kee Huat Auto Sdn Bhd Tel: 04-6265031 • Liong Seng & Son Trading Sdn Bhd Tel: 03-33741998 • LK Utara Auto Sdn Bhd Tel: 04-7339098 • O.C.T.C (M) Sdn Bhd Tel:03-33430779 • P&C Automobile Sdn Bhd Tel:012-3362162 • Power Genius Sdn Bhd Tel: 03-58850823 • Saga Superior Sdn Bhd Tel: 05-3227221 • Taycn Kredit Sdn Bhd Tel:06-6787760 • Urban Truck & Services Sdn Bhd Tel: 012-6237603 • Wiramas Motor Trading Tel: 07-9317233 • Zep-Zhuan Trading Sdn Bhd Tel:09-5676066

# STEELBRO

CONTAINER HANDLING SOLUTIONS

Come visit Steelbro at...

Stand A31 & A32

**PLUS**

Have a go at driving our new model

Visit the booth and test drive the unit to receive a free gift\*

*\*T&C apply – limited to the first 100 customer*

**PAMERAN KENDERAAN BERAT  
TERBESAR DI ASIA TENGGARA**  
20 - 22 JUN 2019, MINES CONVENTION CENTRE

**SOUTH EAST ASIA'S  
LARGEST COMMERCIAL VEHICLE EXHIBITION**  
20 - 22 JUNE 2019, MINES CONVENTION CENTRE



MINES International Exhibition & Convention Centre (MIECC) Sri Kembangan, Selangor, Malaysia

## SB450 sidelifter

- ▲ 45 tonne lifting capacity
- ▲ Massive 3.9m outreach enables easy handling of awkward or misaligned containers
- ▲ 11.8 Tonnes tare weight
- ▲ Best resale value with in-house trade in facility
- ▲ Rapid transfer and best operating times
- ▲ Double Stacking of hi-cube (9'6") containers
- ▲ Robust construction, easy maintenance, operator friendly



## STEELBRO (M) SDN BHD

General Phone: +603 3 176 3833

Sales Phone: +60 19-383 3686

www.steelbro.com

3S Service Provider Central Region

Service Phone: 019 358 7833 or 019 274 7833

Service Email: sbmservice@steelbro.com

2S Service Provider Northern Region  
(Penang & Perak)

AF Mutiara venture

Phone: 604-575 1181

Mobile: 012-475 8909



# Steelbro Sidelifters for container transportation and placement

## Steelbro product support

- ▲ General repairs, full service and service maintenance contracts
- ▲ Repair diagnostics by Steelbro trained technicians
- ▲ Accident and insurance repair work, cranes dismantling and installation services
- ▲ Genuine Steelbro part sales
- ▲ Complete and trade in refurbishment of units
- ▲ 24/7 mobile support within Central Region (Klang valley within 50km radius of Steelbro workshop)
- ▲ Nationwide network of Steelbro approved service agents



Mobile Service Team



Servicing



Genuine Steelbro Spare Parts



General Repairs and Maintenance

## The world's best valued sidelifter

2S Service Provider  
East Malaysia Region  
Intercargo Sdn. Bhd.  
Direct Line: +60 86 253359  
Mobile: 019-8843359

2S Service Provider Southern Region  
(Johor & Singapore)  
XINHWA Auto Engineering Sdn. Bhd.  
Phone: 607-590 0875  
Mobile: 012-779 4223



STEELBRO



## CAMC Heavy-duty Truck, European Standards Definition of new criteria for heavy-duty truck

CAMC new generation heavy-duty trucks are developed by Anhui Hualing Automobile Co. Ltd. by applying world advanced heavy-duty truck technology.

It is powered by high performance common-rail engine with low fuel consumption and high power, complying with Euro III emission standard.



**CAMC**

**DA** DEAUTO INDUSTRIES SDN BHD (881055-M)



4x2  
6x2  
6x4

## PRIME MOVER



**Engine**  
Hino P11C- 350Hp  
Hino P11C- 380Hp  
Cummins ISMe  
420-30 -420Hp

**Transmission**  
ZF Friedrichshafen  
AG. 9/16 speed

**Chassis**  
Double Layer

**Rear Axle**  
Hub Reduction

6x4  
8x4

## MIXER TRUCK



**Engine**  
Hino P11C- 350Hp  
Hino P11C- 380Hp

**Transmission**  
ZF Friedrichshafen  
AG.

**Chassis**  
Double Layer

**Rear Axle**  
Hub Reduction

4x2  
6x2  
6x4  
8x2  
8x4

## RIGID TRUCK



**Engine**  
Hino P11C- 350Hp  
Hino P11C- 380Hp  
Cummins ISMe  
420-30 -420Hp

**Transmission**  
ZF Friedrichshafen  
AG. 9/16 speed

**Chassis**  
Double Layer

**Rear Axle**  
Hub Reduction

# FOTONDAIMLER

AUTOMOTIVE



**MPIRE COMMERCIAL SDN BHD** (1260072-T)

☎ +603 5131 2255    ✉ info@mpiregroup.com.my

🌐 [www.fotonmalaysia.com.my](http://www.fotonmalaysia.com.my)

📍 No. 2, Jalan Gitar 33/3, Elite Industrial Park, Section 33, 40460 Shah Alam Selangor.





MPIRE

**5<sup>th</sup> YEARS**  
**RESALE VALUE**  
**GUARANTEED**



**4 YEARS**  
**UNLIMITED MILEAGE**  
**WARRANTY**





# CONTENTS



## 30 - EDITOR'S NOTE

### MARKET UPDATE

**32** - Mpire Delivers 20 Super Trucks

**34** - Hap Seng Commercial Vehicle delivers Mercedes-Benz Actros to MBA Hauliers Sdn Bhd

**36** - Government to Abolish AVRf

**38** - New Tech Filters from Hengst

**40** - Hammar Models 153 Launched and 190 Delivered in JB







**Continuous Innovation is Quality You Trust**  
**不断创新是您信赖的质量**



See you on 20-22 June 2019 @ MCVE 2019 Booth M21 & M22

For more details, kindly contact us at +6019-776 0753 / +6019-776 0763

# CONTENTS



54

## TECHNOLOGY

- 44 - SAE International May Go For Testing And Validation In The Long Run

## EVENTS

- 52 - Malaysia Commercial Vehicle Expo 2019 Breaks Records

## FEATURE STORY

- 54 - Moving Fuels Safely in East Malaysia



44





# Mercedes-Benz Actros Trucks you can trust.

With a hallmark of the Mercedes-Benz star for over 100 years, Mercedes-Benz Actros adorns premium quality and offers exceptional safety, impressive reliability, fuel economy and exemplary comfort.

Celebrate the joy of the festive season and enjoy a safe and pleasant drive.

Selamat Hari Raya Aidilfitri!

Mercedes-Benz  
Trucks you can trust.



General Distributor: Hap Seng Trucks Distribution Sdn. Bhd.  
No 1, Jalan Kinrara 2, Taman Perindustrian Bandar Kinrara, 47180 Puchong, Selangor  
03 8082 9160  
[www.trucksdistribution.com.my](http://www.trucksdistribution.com.my)

**Authorised Sales & Service Dealers:**

**Johor:** Cycle & Carriage Bintang Bhd (Johor Bahru) 07 238 2299 • **Klang Valley:** Hap Seng Commercial Vehicle Sdn Bhd (Kinrara) 03 8071 1588, Hap Seng Commercial Vehicle Sdn Bhd (Klang) 03 3163 0689, Q-Team Sdn Bhd 03 3176 6088 • **Pahang:** Hap Seng Commercial Vehicle Sdn Bhd (Kuantan) 09 516 2268 • **Perak:** Perak Cycle & Carriage Bintang (Perak) Sdn Bhd 05 354 1819, Hap Seng Commercial Vehicle Sdn Bhd (Ipoh) 05 292 2278 • **Sabah:** Hap Seng Commercial Vehicle Sdn Bhd (Kota Kinabalu) 088 435 043 • **Sarawak:** Hap Seng Commercial Vehicle Sdn Bhd (Kuching) 082 356 886, Hap Seng Commercial Vehicle Sdn Bhd (Miri) 085 651 699

**Authorised Service Dealers:**

**Klang Valley:** Rimbunan Kuasa Sdn Bhd 03 7859 7133 • **Melaka:** Rick Huat Workshop Sdn Bhd 06 336 2978 • **Pahang:** H-Truck Motor Sdn Bhd 09 536 6666



# CONTENTS



## COVER STORY

**56** - CAPAS 2019 Opens Big

## TRAILER TECH

**62** - Steelbro's Latest Sidelifter Offers the Best of Both Worlds

## TRUCKER OF THE MONTH

**66** - A Stress-Free Lifestyle as a Trucker

**67** - Driving into Sunset







# TailGUARD™

## Supports smart and safe reversing, keeping a close eye on blind spots.

Reversing commercial vehicles is a daily challenge. The area directly behind the trailer remains a key blind spot to drivers, who have to take any movement around their vehicle into account at all times.

WABCO TailGUARD™ helps to avoid accidents as well as damage to trailers. Ultrasonic sensors detect if the area behind the trailer is safe, and TailGUARD™ brakes the vehicle automatically at a pre-set distance between 50 and 200 cm from an object in the rear blind spot. Directly resulting in new levels of safety for drivers and fleets.

### Improved safety, less damage

- ✓ Supports safe reversing
- ✓ Reduces the number of potential accidents when reversing
- ✓ Helps to avoid costly vehicle damage and downtime

### The rear blind spot detection system that automatically stops the vehicle

- ✓ Rear blind spot detection system for commercial vehicles
- ✓ Automatically activates when the driver shifts into reverse
- ✓ Up to six ultrasonic sensors measure the distance to objects behind the vehicle
- ✓ Automatically brakes when the vehicle approaches objects within a pre-programmed distance between 50 and 200 cm
- ✓ For vehicles equipped with ABS or EBS, active braking and distance indication is visible on the WABCO Trailer Remote Control
- ✓ Warns the driver with a pulsating brake pedal when exceeding a speed of 9 km/h
- ✓ Available for both trucks (with ABS and EBS) and trailers (with EBS)



TailGUARD™ helps to avoid accidents as well as damage to trailers or loading docks.

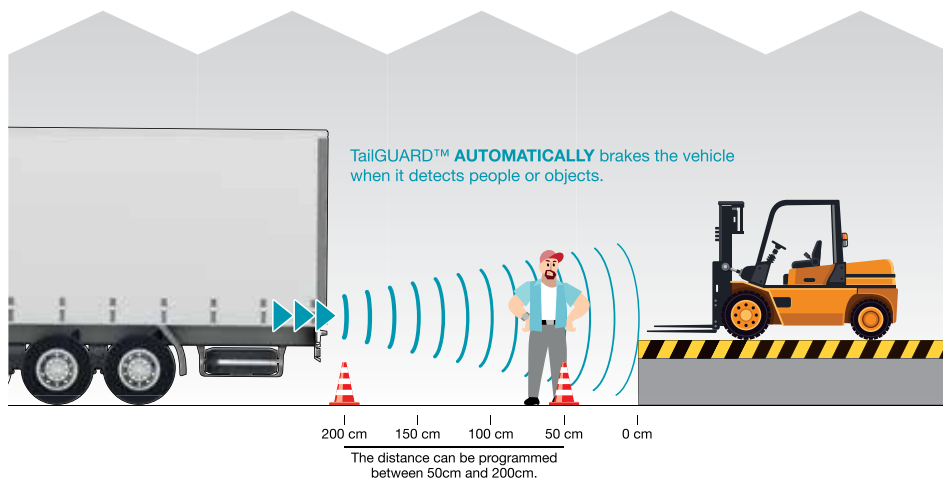

WORKS WITH >>>



Trailer EBS



OptiLink™



# WABCO

# CONTENTS



## TYRE TECH

**68** - Traceability and "Health" Issues for Commercial Tyres

## SAFE ROADS

**69** - Two Japanese Companies' Efforts for Safer Malaysian Roads

**70** - Real-time driver fatigue and distraction prevention Technology

## SPECIAL REPORT

**72** - Hino's Atsushi Uchiyama Transformation Plans

**74** - TRUCK FEATURE







# DAIHATSU

The Better  
**ADVANTAGE**

Business  
on the **GO**



Panel Van  
Automatic  
Transmission



## MALAYSIA COMMERCIAL VEHICLE EXPO 2019

Date : 20<sup>th</sup> - 22<sup>nd</sup> June 2019 | Time : 10.00am - 7.00pm

Venue : Malaysia International Exhibition & Convention Centre (MIECC), Kuala Lumpur

The largest exhibition dedicated to commercial vehicles in South-East Asia.

# Visit Daihatsu Booth M34 & M35 Main Hall



### Special Promo:



Attractive Rebates\*



Special Preview  
Custom Built  
Gran Max



#FreeTreeGiveaway



FREE HD Car Dash Cam



Free Goodie Bags



Free Express Health  
Check-up

In Collaboration with:



DAIHATSU (MALAYSIA) SDN BHD  
(A subsidiary of MBM Resources Berhad - 284496-V)  
Customer Hotline: 03 - 5510 1399

www.daihatsu.com.my | daihatsumalaysia

# CONTENTS



76



86

## TEST DRIVE

**76** - UD Trucks Check & Drive

## COMPANY PROFILE

**80** - Tatt Seng Jaya Automobile

## IN THE WORKSHOP

**82** - MAN Keeps Melaka's Trucks Mobile

**84** - Daihatsu Malaysia's Commitment to Provide the Best for Customers

**86** - Father's Work Ethics and Son's Vision Ensure Lam Mah's Success

**87** - HEADLIGHTS



82





UD TRUCKS

NEW **Quester**

Made to go the extra mile



# A Smart Move For New Possibilities

New Quester's flexibility makes it suitable across a variety of applications and segments such as general cargo, long haul and construction.

And now, **ESCOTS'** added power and performance in New Quester means assignments can be carried out with increased fuel and driver efficiency.

Optimized specifications such as reduced tare weight allow you to carry more. And with the introduction of smart new connected features such as telematics, you can stay on top of your tough daily schedule.

**A smart move for your business. Going the Extra Mile.**



*Image is for illustration purpose only. Actual vehicle specification may vary from model shown.*

\*Source from Malaysian Automotive Association (MAA) report 2018.



**TAN CHONG INDUSTRIAL EQUIPMENT SDN BHD** (013285-X)

A subsidiary of Tan Chong Motor Holdings Berhad (12969-P)

Lot 3, Jalan Perusahaan Satu, 68100 Batu Caves, Selangor Darul Ehsan, Malaysia.  
Tel: 03-6189 9832 Fax: 03-6189 9336 Website: [www.tcie.com.my](http://www.tcie.com.my)

**Branches:** • Batu Caves Tel: 03-61891896 • Bukit Mertajam Tel: 04-5381308 • Ipoh Tel: 05-2921028  
• Johor Bahru Tel: 07-3538808 • Klang Tel: 03-31669609 • Malacca Tel: 06-3366957 • Sabah Tel: 088-499228  
• Sarawak Tel: 082-488811 **Authorized Dealers:** • Combine Motor Sdn Bhd Tel: 03-61363060  
• Commercial Junction (M) Sdn Bhd Tel: 07-4333998 • Derchin Auto Sdn Bhd Tel: 07-3864108 • Edaran Setia Auto Sdn Bhd Tel: 09-5162288 • Kee Huat Auto Sdn Bhd Tel: 04-6265031 • LK Utara Auto Sdn Bhd Tel: 04-7339098 • Taycn Kredit Sdn Bhd Tel: 06-6787760 • Zep-Zhuan Trading Tel: 09-5676066



# CONTENTS



## FACILITIES

- 88 - Hap Seng Commercial Vehicle 3S Centre Opening at Kuantan
- 89 - The 12 Waves

## PRODUCT FOCUS

- 90 - Lighter and Harder is Better for Your Trailer
- 92 - B&B Transport Saves More with Valeo Coolants

## 94 - NEWS & NOTES





**Hengst**<sup>®</sup>  
FILTER



Visit us in  
**BOOTH M07**



# Work smarter.

Filters and lubricants in OE quality



Hengst Asia Pacific | 25 Bukit Batok Cres. | #10-10 Elitist | SG 658066  
T +65 6818 2880 | E info@hengst.de | [f](#) HengstAPAC

# The Drivers **ASIAN TRUCKER**

**YOUR GUIDE TO ALL THINGS TRUCK**

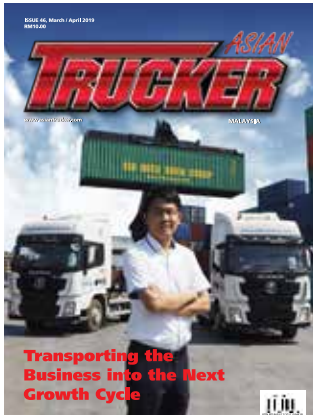

PDF versions are available for download at [www.asiantrucker.com](http://www.asiantrucker.com)

## EDITORIAL

**EDITOR** Stefan Pertz  
**WRITERS** Farezza Hanum Rashid  
Carol Yeoh  
Tony  
**GRAPHIC DESIGNER** Floyd Cowan  
**PHOTOGRAPHERS** Farezza Hanum Rashid  
Carol Yeoh  
Stefan Pertz

## CONTRIBUTORS

Floyd Cowan  
T. Murali

## ON THE COVER

Shawn Yeo  
Business Executive of Sin Hock Soon

## ADVERTISING

Nicole Fong  
[Nicole@asiantrucker.com](mailto:Nicole@asiantrucker.com)

## SINGAPORE

Floyd Cowan  
[Floyd@asiantrucker.com](mailto:Floyd@asiantrucker.com)

## THAILAND

Songyot Kamontavikun  
[Songyot@asiantrucker.com](mailto:Songyot@asiantrucker.com)

## ASIAN TRUCKER DRIVERS CLUB

Sponsorship / Membership  
[info@asiantruckerclub.com.my](mailto:info@asiantruckerclub.com.my)

## CIRCULATION, CONTRIBUTIONS and SUBSCRIPTION

[info@asiantrucker.com](mailto:info@asiantrucker.com) WEBSITE and E-NEWSLETTER  
[www.asiantrucker.com](http://www.asiantrucker.com)

## PUBLISHED BY

Asian Trucker Media Sdn. Bhd. No. 27-1, Block C, Zenith Corporate Park,  
Jalan SS7/26 Kelana Jaya, 47301 Selangor, Malaysia [www.asiantrucker.com](http://www.asiantrucker.com)

## ARTICLES

Asian Trucker is a registered trademark of Asian Trucker Media Sdn. Bhd. All articles submitted for publication become the property of the publisher. The editor reserves the right to adjust any article to confirm with the magazine format.

Asian Trucker is a bi-monthly publication. The publisher will not be responsible for any copyright violation of articles that have been approved by contributing writers. The publisher accepts no responsibility for unsolicited manuscripts, illustrations or photographs.

## PRINTED IN MALAYSIA

Percetakan Osacar Sdn Bhd (Co.Registration : 63461-W)  
No 16 Jalan IDA 1A, Industri Desa Aman, Kepong, 52200 Kuala Lumpur

## DISTRIBUTED BY

MPH Distributors Sdn Bhd ( 5048-A) Ground Floor Warehouse, Bangunan TH  
No 5, Jalan Bersatu Section 13/4 46200 Petaling Jaya  
Selangor Darul Ehsan Malaysia

Boost your business with a listing on our new website.  
Find businesses or sell your truck, upload your events or images to the gallery.  
Visit our new website [www.asiantrucker.com](http://www.asiantrucker.com) to put your company on speed.





**MAN | Service**

012 - 255 8626



**PARTS WARRANTY**



**ECOLINE PARTS**

**MAN | Mobile24**

1- 800 - 88 - 8626

# Simplifying Business with MAN

## Integrated solutions to simplify your business

Our comprehensive range of services in MAN After Sales cover everything – from 2-year warranty, preventive maintenance, ServiceContracts, MAN Genuine Parts ecoline, quality training and more. So, you can focus on your business and we'll do the rest.

MAN After Sales – it's easy because we make it easy.

MAN Truck & Bus (M) Sdn. Bhd. (224536-W)  
Lot 4, Jalan Industri 3/2,  
Taman Industri Integrasi Rawang,  
48000 Rawang,  
Selangor Darul Ehsan.

T • 603-6092 6977 F • 603-6092 6966 W • [www.man.com.my](http://www.man.com.my)

**MAN kann.**





stefan@asiantrucker.com



**W**e are in our tenth year of publishing Asian Trucker. Over the years I have seen staff move, new people coming to Malaysia and new technology emerging. In recent years, I've noticed that there have been a lot more players coming into the market and brand new companies emerging with innovative ideas. Maybe the most fabled one is Tesla.

Mobile apps are now available in abundance and new services from young companies are readily available. However, one of the questions I have is about the sustainability of these newcomers. Sometimes, an idea is good as a concept, but for all the trying, the company may not be able to get the business off the ground.

# The Emergence of New Players

Take for instance the O-Bike. Brilliant idea as a concept. But unfortunately, not viable in the long run.

As a reporter, I am always intrigued by what is new and how the business world is changing. At the same time, I am also critical. Sometimes I would want to create a file on all the innovations we have written about and re-visit these companies and brands after a few years to see "how it's going". Naturally, that would also make for good story-telling as one can refer to "what happened so far".

For this issue we met with a number of people who not only have good ideas and innovative products, but also demonstrate how to remain successful in business. One interview I looked forward to was with the new Managing Director of Hino Motors Sales Malaysia, Atsushi Uchiyama. I hope his ideas and thoughts can be implemented. Also showing something new is UD, which adds a new model to their tested and proven line-up of trucks. Whenever I meet with Kenneth Teh from Kit Loong, he is full of ideas, one of which we feature in this issue. These companies, as well as others of course, have been thriving. One common thread can be found: they all focus on the customers' needs.

Speaking of customers, I was thrilled to meet with a group of business owners in Melaka on a Sunday to discuss their requirements and how MAN addressed their issues with the mobile workshop. Although I have been to Melaka many

times, I haven't been to these famous food places we stopped in for breakfast, lunch and dessert. As anyone travelling can tell you, the best food can be found where the truckers have their meals. Not to worry, we will not turn this magazine into Asian Tucker, although I am tempted to have a section on good places to eat when you are on the road.

Recently we ran our annual customer survey. We try to find out what it is that you would want us to feature, report about or push harder. There are a few things that we will not do, for example report accidents or write about trucking in a way that makes it look like a bad industry to be in, but otherwise we are very open to suggestions. Please, let us have your input as to what you would want us to report and we shall see how we can integrate it. We, too, need to innovate in a sustainable way. In the meantime, please be careful on the road.

Stefan Pertz  
Editor, Asian Trucker Malaysia







# THINK OUTSIDE THE BOX

While some define the value of their payload in terms of weight, you have a wider perspective. Literally. Driving volume cargo is all about time and space. About making the most of it. About optimising your vehicle to make space for that extra pallet that will put you ahead of your competition. This is why we don't do one-size-fits-all trucks. No. At Scania, we tailor solutions for the only business that matters. Yours.

Call **+603 7845 1000**, email **smyenquiries@scania.com** or visit **www.scania.com.my** today and ask for how sustainable transport solutions can help your business achieve the best profitability.

 [fb.com/scania.malaysia.sdn.bhd](https://www.facebook.com/scania.malaysia.sdn.bhd)

 [linkedin.com/company/scaniamalaysia](https://www.linkedin.com/company/scaniamalaysia)

# SCANIA

Scania (Malaysia) Sdn Bhd (518606-D), No.1 Jalan Tiang U8/93, Bukit Jelutong Industrial Park, 40150 Shah Alam, Selangor D.E. Malaysia

Scania pursues an active policy of product development and improvement. For this reason the company reserves the right to change specifications without prior notice. Furthermore, due to national and legal requirements, some accessories may not be available in local markets. For more information about our new truck generation and services, please visit [www.scania.com.my](http://www.scania.com.my)





and quarry tippers as well as logging and timber transportation. This is a testament to the highly adaptive features of the EST in its ability to perform in a all sorts of environments. "Foton Daimler is a joint venture company of Daimler, parent company of Mercedes and also the largest truck manufacturer in the world and Foton, the largest commercial vehicle brand in China. This truck is designed by Daimler, built by Foton, the engine is made by Cummins in America and the gearbox is made by ZF in Germany. It is a world-class truck at a more competitive pricing that suits the current and future needs of the Malaysian logistics industry," said Goh.

"All 20 units of the trucks delivered to PKT come equipped with ADAS (Advance Driver Assistance Systems). Both Mpire and PKT have always emphasized on the safety of truckers, so it was an easy decision for PKT to upgrade their trucks with ADAS. ADAS is a highly resilient device that has adaptive cruise control, blind spot detection and lane departure assistance to help enhance the safety of drivers and to make deliveries more efficient. A system from Korea, ADAS will greatly ensure the efficiency and safety of PKT's truckers. I am confident that our Foton Daimler trucks will serve PKT well and most importantly, increase their return of investment with better efficiency and higher productivity," he concluded.

The Foton Daimler trucks from Mpire Group come with four years warranty with unlimited mileage. **F**

## Mpire Delivers 20 Super Trucks

***PKT Logistics added Foton Daimler EST Prime Movers to their growing fleet.***

**M**pire delivered 20 Foton Daimler EST prime movers to PKT Logistics at their 12 Waves warehouse in Batu Kawan, Penang. The event took place on the 11th of April at the Batu Kawan One Auto Hub which is slated to emerge as one of the largest automotive logistics provider in the country to cater to the needs of the automotive industry under the purview of the Northern Corridor Implementation Authority.

Speaking at the event was Dato Billy Goh, Group Managing Director of Mpire Group. "I am extremely happy to hand over these 20 units of Foton Daimler trucks to my mentor and good friend of 15 years, Dato Michael Tio, Chief Executive and Managing Director of PKT Logistics Group. Even before the launch of Foton Daimler by Mpire last August, PKT and Dato Michael Tio have pledged their support to us with an initial order of seven units of the manual transmission EST. They then made a repeat order for an additional 13 units of the EST. Soon, we are expecting another order for ten units."

Within a span of six months since the launching, Mpire has received bookings of more than 120 units of Foton Daimler trucks of several variants. They have also served a wide range of customers including those in cargo transportation, container hauliers like PKT Logistics, palm oil and palm kernel hauliers, mineral



# JOIN US AT

## LARGEST SOUTH EAST ASIA'S COMMERCIAL VEHICLES EXPO

2019 MALAYSIA COMMERCIAL VEHICLE EXPO

**20 - 22**  
JUNE 2019

**MIECC** - Malaysia  
International Exhibition  
& Convention Centre

**BOOTHS M09, M10, M17, A11-14, A21-25**



**PARTNER WITH:**



**TOGETHER WITH:**

SHAANXI TRUCKS SDN BHD





## Hap Seng Commercial Vehicle delivers Mercedes-Benz Actros to MBA Hauliers Sdn Bhd

**H**ap Seng Trucks Distribution Sdn Bhd (HSTD) together with authorized dealer, Hap Seng Commercial Vehicle (HSCV), has recently handed over the second batch of four units of a total 12 units of Mercedes-Benz Actros prime movers 2644 LS to MBA Hauliers Sdn. Bhd.

MBA Hauliers Sdn. Bhd. is a sister company of Orion Base Shipping Sdn Bhd and was founded in 1995. The parent company is involved in the total logistic business including shipping, freight forwarding, ship-to-ship transfer, haulage, warehousing and more. MBA Hauliers has a fleet of trucks and is the provider of land transportation for the company. They have the capabilities to transport heavy and huge sized shipments to locations where it may be required and fully equipped with GPS trackers as MBA Hauliers understands the importance of security for their clients to ship goods to their destination end point.

The handover keys were presented by HSTD Chief Executive, Mr Roland Schneider and HSCV Chief Operating Officer, Wong Leh Seng to the Managing Director of Orion Base Shipping Sdn Bhd, En Muhammad Amirul Hafiz bin Dato Mustafa.

According to Wong, HSCV is one of the key dealers for Mercedes-Benz commercial vehicles in Malaysia. "Our experience with Mercedes-Benz trucks started some 40

years ago. Our passion for excellence has been a major driving force behind the success of the Mercedes-Benz trucks. We are very happy to bring the brand's confidence and reliability to our customers. We understand the needs of our commercial vehicle customers whose businesses rely heavily on the reliability of their vehicles to keep their business running like clockwork without compromising on the drivers' safety and comfort. We are proud to be a partner of MBA Hauliers and are indeed very happy that they have placed their trust in Mercedes-Benz Actros for the sustainability of their businesses," said Wong.

Meanwhile, HSTD Chief Executive, Roland Schneider said that it was a special day for HSTD on this delivery of the second batch of four (4) units of Mercedes-Benz Actros prime movers 2644 LS and he hopes to get more support from the customer.

Also present at the event were Adun Port Klang, Yang Berhormat Azmizam Zaman Huri, Director of Orion Base Shipping Sdn Bhd, En. Muhammad Arif Hakim bin Dato Mustafa, HSTD Director of Commercial Vehicle Operations, Albert Yee and HSCV General Manager of Sales & Operations, Derrick Sim. **T**





HOW TO  
**IMPROVE  
 YOUR FLEET  
 DEPOT'S**  
 EFFICIENCY  
 FURTHER

Proven Operational Efficiency



### We Are The Answer.

At Kit Loong Fleet Solutions, we offer a proven successful truck retail model that can add value to your business while minimising downtime. Besides supplying tyres, we also share our experience and professional know-how with your team to keep operations running smoothly. Your crew will be able to upgrade essential skills such as proper tyre application, tyre pressure monitoring, and more. In addition, you will also enjoy our KL 24/7 Tyre Rescue Service anywhere in Peninsular Malaysia. With the right training, equipment, knowledge, tools and tyre management software, we'll move your business towards achieving the benefits of SC3 and also increase your business KPI. With the right know-how, technical expertise, innovation and 80 years' experience, you can count on us to keep you competitive, minus the downtime.

**KIT LOONG**  
 FLEET SOLUTIONS

SC3 delivers the benefits of safety, competitiveness, control and cost-effectiveness through the KL Sigma formula, a proprietary tool that combines a sum of technical know-how, understanding of tyre movement essentials and product expertise.

Retreading Process Technology

Tyre Distribution

Retailing Services

24/7 Tyre Rescue Service

Total Tyre Management

Strategic IT Solutions

Training & Consultancy

System Franchising





# Government to Abolish AVRF

*The government's re-evaluation of the AVRF found several issues concerning a rise in the cost of doing business and an imbalanced environment for competition.*

**T**ransport Minister Anthony Loke Siew Fook recently announced that the Government has decided to abolish the Ad Valorem Registration Fee (AVRF) that was imposed on locally-made trailer and semi-trailer trucks.

The abolition will be carried out in a two-month period to enable work to amend procedures and preparations for the Road Transport Department (JPJ) registration system to be properly done, Loke said in a statement.

AVRF is a registration fee imposed on motor vehicles, with the amount calculated according to the value of components used in the manufacture of the vehicles concerned, and where the vehicles are exempted from import and excise duties.

Loke said the Ministry had re-evaluated the implementation of AVRF and found several issues concerning a rise in the cost of doing business and an imbalanced environment for competition, due to the fact that the locally-produced trucks have become more expensive than imported ones. He added that based on existing regulations, vehicles exempted from import duty including locally-made vehicles will be imposed AVRF during registration and sales tax by the Malaysian Royal Customs Department. For imported vehicles, AVRF was waived because they had been imposed import duty and sales tax.

However, Malaysia has now signed bilateral free trade agreements (FTAs) with several countries, including Japan, Pakistan, India, ASEAN, China and South Korea

under which, trailer and semi-trailer (trucks) imported from the countries concerned are exempted from import duty. Apart from this, sales tax exemption is also given to container trailer trucks bought from manufacturers licensed under the Sales Tax Act 1972. As such, all imported vehicles involved in the exemption of import duty and sales tax have generally been exempted from paying any fee including AVRF.

Loke said this has created an uneven playing field where manufacturers of locally-made vehicles are subjected to AVRF and sales tax. Furthermore, manufacturers of local vehicles also have to compete with suppliers of new imported vehicles which have lower and more competitive cost elements.

The fee abolition would also create a uniform business environment between Peninsular Malaysia and Sabah and Sarawak. Loke said that presently, only vehicle owners who import vehicles into Peninsular Malaysia from Sabah and Sarawak are exempted from AVRF. "The standardisation of vehicle fee policy for trailers and semi-trailers built in Peninsular Malaysia, Sabah and Sarawak will ensure that vehicles built throughout Malaysia will enjoy the same privileges," he said.

Loke also expressed confidence that the local manufacturing industry with its 40 to 50 years of experience can compete with distributors of imported vehicles. **T**





**中国重汽**  
**SINOTRUK**



**Sendok Group**

**T7H**  
**540HP**

FIRST CLASS QUALITY  
YOU CAN AFFORD



**5 YEARS UNLIMITED MILEAGE WARRANTY**

\*Terms & Conditions Apply

**SINOTRUK MODELS LINE UP**

**T SERIES**



AVAILABLE IN  
T5G & T7H  
EURO III 330HP/430HP/  
540HP

**A7 SERIES**



4x2,6x4,6X4 PRIME MOVER  
4X2,6X4,8X4 RIGID TRUCK  
EURO II 371HP/420HP

**SWZ SERIES**



4x2,6x4,8x4 RIGID TRUCK  
EURO II 336HP

**40T-70T**



MINING TRUCK  
OFF ROAD RIGID TRUCK

SINOTRUK is driven in over 90 countries, as the importer and assembler in Malaysia, Sendok Group is the official distributor of SINOTRUK in Malaysia since 2009. Experienced in large and small fleet delivery, our products include all types of bodies and specifications such as cargo, mixer, tipper, pump truck, water tank, oil tank, special purpose vehicles and etc. We provide our best products and services to our customers' businesses at an affordable price tag!

**Central Region:**

Sino Truck Commercial Vehicles  
(M) Sdn Bhd  
Lot 3200, Batu 3 1/4,  
Jalan Kapar, 41400 Klang,  
Selangor.  
Tel: 019-2681430 / 03-33445588

**Southern Region:**

**China Auto Manufacturers  
(Johor) Sdn Bhd**  
Lot 7635, Jalan Permas Timur  
Off Lebuhraya Pasir Gudang,  
Bandar Permas Jaya 81750  
Plentong, Johor.  
Tel: 012 - 7882555 /  
07 - 3808296

**East Coast Region:**

**China Auto Manufacturers  
(Kuantan) Sdn Bhd**  
Lot 3485, Batu 3 1/2,  
Jalan Gambang,  
25150 Kuantan, Pahang.  
Tel: 012 - 9380833 /  
09 - 5361088

**Sarawak:**

China Auto Manufacturers  
(Kuching) Sdn Bhd  
Lot 502, Block ,13th Miles  
Kuching Central Land District  
Jalan Kuching-Serian, 93250  
Kuching, Sarawak.  
Tel: 016 - 860 4069

**Sabah:**

**Angco Machinery Sdn Bhd**  
Lot 4A Block T Phase 111,  
Bandar Ramai Ramai,  
Leila Road P.O.Box  
3535,90739 Sandakan,  
Sabah.  
Tel: 013 - 888 6123



**Sendok Group**  
www.sendokgroup.com

**Headquarter:**

Sendok Group Building - Lot 1564, Batu 4, Jalan Kapar, 42100 Klang, Selangor Darul Ehsan, Malaysia  
Tel: + 603-3345 5600 Fax: + 603-3290 2286 Email: sinotruk@macv.com.my **SendokGroup**

# New Tech Filters from Hengst

**F**ilters keep the air and fluids in trucks free from harmful contaminants. Filtration expert Hengst has a few tips and updates on how to make the most out of them.

Air Filter Safety Inserts come in handy when maintaining filters. They should be seen as a backup plan for filters. Safety inserts of the primary air filter are often not replaced to save some extra money. This can end up to be a rather costly thought process. Safety inserts are a second stage filter with less filtration efficiency than the primary air filter. The safety insert is placed inside your primary and functions simply as a back up to protect your engine:

- During the replacement process of your primary filter the engine remains covered by the safety insert,
- Your primary filter might be damaged and has a bypass. Remember, damages of air filters are easy to happen during the cleaning process (not recommended) for a second use,
- If the primary air filter is cleaned, dust particles are likely to settle on the inside (clean side) of the filter, and sucked into the engine immediately after start,
- From possible bypasses of the primary due to installation faults. Important to know is that the safety insert is not a spare filter, it is simply second life-line for your engine, if the primary air filter fails to perform to get you to the next service station,



De-dusting filters cause particles to resettle on the clean side which will be sucked into the engine immediately at first start. Safety Inserts can assist in protecting your engine.

Left: E1013L Air filter, Right: E1013LS safety insert. "L" stands for "Luft" which is the German word for "Air". "S" stands for "Sicherheitseinsatz" which is "safety insert" in English.

## The Hengst Flex Tape

The Hengst Flex Tape is a newly implemented production technology to improve the performance of air filters for heavy duty applications. It offers the following advantages:

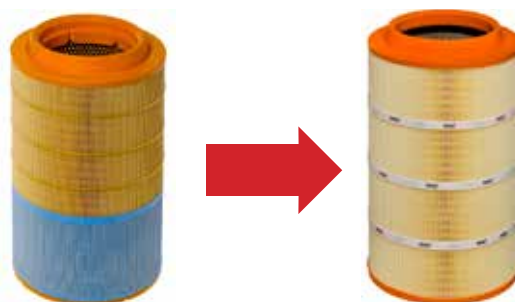

- Higher dust holding capacity
- Increased collapse resistance
- Stronger than common stabilization grid
- Stronger than conventional glue beads
- Improved wet strength in rainy and foggy conditions
- No deformation of filter throughout service life
- Hengst branded to underline genuine OE quality

The Hengst Flex Tape has been developed in Germany and laboratories have tested and certified the new design. The changeover will take place successively over the next month.

## Also new: The Hengst Premium Box

Besides highlighting the quality difference to competitors and replicators, Hengst wants to ensure a further distinguishable difference, noticeable at first sight. Therefore, they chose to design a new layout for the cardboard boxes to line up with the OE quality standard of their products. 





# Lift your business with Cranes & Hookloaders from HYVA!

**HYVA**<sup>®</sup> LIFT

**HYVA**<sup>®</sup> CRANE



Hyva (Malaysia) Sdn Bhd lot 21, Jalan 4/32A, Kepong Industrial Estate Batu 6.5, 52100 Kepong.  
Kuala Lumpur, Malaysia. Tel.: +603-62573319 Fax: +603-62597475 sales@hyva.com.my

[www.hyva.com](http://www.hyva.com)





***The Hammar 153 Mega Transfer is the safest, quickest and most versatile in the market.***

The Hammar 153's SWL is 45 tonnes, container size is 20' to 40' (45' is optional), tare weight is from 10 800kg, has a handling time of three to four minutes, and its power source is truck hydraulics (PTO) or powerpack.

Present at the event were Director of Hammar Australia, Peter Levison, Director of Hammar Malaysia, Chris Joon and Sales Manager, Eugene Joon. There were also many of Hammar's customers there to see a demo of the Mega Transfer. "Malaysia is the second largest market for Hammar with 600 units of sideloaders operating in the country while Austria, the first, has over 700 units," (Eugene) Joon said.

Levison reflected how apt it was that as Hammar turns 45 years old this year, they are revealing a 45-foot capability Mega Transfer in Malaysia. "We have been around since 1974 and have only focused on sideloaders, and we invest heavily worldwide. The Hammar 153 is by far the safest, quickest and most versatile sideloader in the market, and is very suitable for the Malaysian market. It has already been used around the world for quite some time, but I think it will do better in the Malaysian market," he said.

Meanwhile, Joon said the launch of the Hammar 153 in Johor was appropriate as Johor was the gateway

## Hammar Models 153 Launched and 190 Delivered in JB

**H**ammar revealed the Hammar 153 Mega Transfer on May 4 at EcoWorld in Senai, Johor Bahru. The Hammar 153 was designed with strength and versatility in mind. It has two different support legs, front and rear (interchangeable); the 155 StepOver leg for extra stability and quick transfer operations, and the tilting and telescopic 151 leg for extra flexibility.

Transferring with the 155 leg is quick, safe and easy and it gives extra stability and lower ground pressure. If space is limited for transfer, the 155 leg can be folded. The versatile, telescopic tilting 151 leg can be tilted up to 90 degrees, but with lower Safe Working Load (SWL). For transfer, the 151 leg can be put on top or below the other chassis.



# GET 2.88% P.A ON YOUR LOAN

Finance your trucks with  
Volvo Financial Services today

VOLVO  
TRUCKS  
MALAYSIA

50  
YEARS OF  
INNOVATION  
1969-2019



Volvo Financial Services provides a full range of financial services to all Volvo Trucks customers. We are part of the Volvo Group and this has made us an expert in your vehicles and your industry. We develop solutions that deliver an exceptional customer experience, respond to changing business models, and meet the demands of today's changing environment.

For more information on this special offer, please contact our sales representative or our VFS representative, Mr Steven Kwok at 016-330 3688.

Now you can find us on



volvotrucksmalaysia



volvotrucksmalaysia

Volvo Trucks. Driving Progress







for sideloaders into Malaysia in 1978. "Prior to that, business owners used to rent sideloaders from Singapore. When it was exposed to Johor, more companies started to realise the benefits of sideloaders and they began to purchase second hand sideloaders," he said. In 1982 two new units came to Malaysia and from 1986 to 1994, about 50 sideloaders were being used in Port Klang, while Johor had three units. "Now that Johor is highly developed, the government wants more investments and companies have to be more efficient. Now in Johor there are around 70 units of sideloaders of various brands," (Chris) Joon said.

Also taking place on that day was a handover of the Hammar 190 to BW Group, a logistics company in Johor Bahru. Receiving the key to the 190 was BW Group Managing Director Richie Seau. The company deals in ocean logistics, air freight services and land services comprising of warehousing, equipment infrastructure, forwarding services as well as export-import of cargo load via the group's companies BW Haulage Sdn Bhd, BW Ocean Sdn Bhd, BW Global Logistics Sdn Bhd and BW International Sdn Bhd. **T**





Conti Hybrid **HS3**

Conti Hybrid **HD3**

Conti Hybrid **HT3**

ContiUrban **HA3**

ContiCoach **HA3**

## Generation 3.

Driven by your needs.

- Offers best tyre mileage in class
- Developed specifically for Asian road conditions
- High value premium casing for enhanced retreadability



## SAE International May Go For Testing And Validation In The Long Run



*SAE International is a global association committed to be the ultimate knowledge source for the engineering profession. By engaging nearly 200,000 engineers, technical experts and volunteers each year, it drives knowledge and expertise across a broad spectrum of industries. It acts on two priorities: encouraging a lifetime of learning for mobility engineering professionals, and setting standards for aerospace, automotive and commercial vehicle industries. Recently, T Murralli of AutoParts Asia caught up with Dr David Schutt, CEO, SAE International, to get to know how SAE International has been pursuing its mission to develop standards for the next generation mobility including connected vehicle and autonomous driving.*

**Q: Can you describe the initiatives taken by SAE for autonomous driving?**

Schutt: We are approaching autonomous driving from a broad perspective covering the entire waterfront. The technology is developing and there are multiple paths to accomplish it. One of the most interesting things right now is the area of safety, enabling the industry to approach it in a pre-competitive way.

For example, the aerospace industry does not compete on safety, quality or the environment. The automotive industry is beginning to recognise that any bad-acting car is a problem for the whole system, so there has to be a common set of safety principles. The way they achieve it may vary but they should not be competing on safety. That is also one of the largest barriers right now for public acceptance of these vehicles. We are doing some public demonstrations on this where we take the public on test drives in these automated vehicles and look at the change in their experience before and after the drive. There are some surprising things we have learnt from it.

**Q: How is this going to help SAE evolve and develop standards in this area?**

Schutt: Standards come up when technology collaborates together. There are so many areas we are working on at present, from ADAS to the communication protocols to safety principles. We are also beginning to deal with the human-machine interface; how does the passenger know that the vehicle is being driven autonomously. We are used to making eye contact with the driver to tell him where to go, but how do you do that in a car without the driver. So we are looking at all these different facets, including cyber security. We have a whole set of standards in the automotive industry that build on the fundamental



# GENUINE VOLVO COOLANTS. GET 50% MORE TODAY

VOLVO  
TRUCKS  
MALAYSIA

50  
YEARS OF  
INNOVATION  
1969-2019



## Don't risk it. Act now.

Using an inferior coolant can cause corrosion, leakages, deposits, and overheating of an engine's cooling system, which will seriously damage your Volvo engine. Therefore, it is important to use only Genuine Volvo Coolants which are specifically tailored for Volvo trucks.

In conjunction with Volvo Trucks Malaysia's 50th anniversary, you can now purchase and change or stock up on coolants at a fraction of the retail price. For a limited time only.

For more information please contact your authorised Volvo workshop or call our Customer Care Centre at 012-373 1030 or 019-240 1030.

Now you can find us on



volvotrucksmalaysia



volveotrucksmalaysia

Volvo Trucks. Driving Progress



principles of a cyber-secured vehicle, which is being adopted across the industry right now. We have kept it simple so that a regular member of the public can read and understand the difference between Level-0 and Level-4. We are now looking at Level-4 and Level-5; in the US there is a debate on whether or not to skip Level-3 as it's a complicated area. Europe and Japan are already working on Level-3. The US might have to reconsider skipping it.

**Q: Is there any advantage in skipping Level-3?**

Schutt: The desire to skip Level-3 was to pass over the very ambiguous high liability stage but technologically it has to be done. We will have to go through Level-3 for a phase of time.

**Q: There is always a clash between the regulatory side and technology. In some cases technology is matured but regulatory systems are not confident enough to approve it, also vice-versa. In this scenario how would SAE propagate standards?**

Schutt: SAE's approach is not to define a specific technology but to describe a performance or requirement or expectation from it so that multiple technologies could deliver that same result, or if technology advances it could also be incorporated. There are regional differences. Europe often focuses on a specific technology; we are not opposed to that but are looking for a portfolio of solutions that would allow us to advance further. For example,

with the movement from 4G to 5G, if you want a specific technology you have to be right with the standards or regulations while our standards encompass the regulatory framework which is performance-based. In the US, NHTSA (National Highway Traffic System Administration) is trying to find the best pathway for it in this very complex and new dynamics. We are working with them to help the portfolio standards that would help ensure that the policy is accepted.

**Q: When do you think the autonomous vehicle will come to the general arena?**

Schutt: Most people believe we are first going to see it in fleets, in relatively defined environments. As we gain use cases on vehicles and consumer's comfort and acceptance, I think we would be able to get further and further out to the edges. The other thing is there has to be a strong infrastructure; you are going to find that in cities.

**Q: Do you see this happening in developed markets five years from now?**

Schutt: Certain cities are investing more quickly than others. They have public demonstration days; the state of Florida is fairly progressive, wanting to develop corridors for this. We are doing a number of public demonstration projects in Florida as the state legislation is open to us. The state has a number of retirees who sign up as they see this as an important step in which they want to participate. It's



# RANGE VARIETY

**NEW IN SINGAPUR**

**MS MOTORSERVICE TRADING (ASIA) PTE. LTD.**

29 International Business Park · #06-01, Acer Building · Singapore 609923  
Phone: +65 657 29 498 · Fax: +65 657 29 471 · [www.ms-motorservice.com.sg](http://www.ms-motorservice.com.sg)

OUR HEART BEATS FOR YOUR ENGINE.







UD TRUCKS

NEW  
**Quester**  
Made to go the extra mile

# Your Way To Save Fuel

Numbers don't lie. Rising fuel costs are tightening margins. It's tough to take your business where you need it to be.

New Quester introduces **ESCOT** automated manual transmission, which builds on the current Quester's excellent fuel economy. Automated gear shifting makes all drivers more efficient, contributing to better drivability and helping you make the break towards greater profitability.

**A smart move for your business. Going the Extra Mile.**



\*Source from Malaysian Automotive Association (MAA) report 2018.

*Image is for illustration purpose only. Actual vehicle specification may vary from model shown.*



**TAN CHONG INDUSTRIAL EQUIPMENT SDN BHD** (013285-X)

A subsidiary of Tan Chong Motor Holdings Berhad (12969-F)

Lot 3, Jalan Perusahaan Satu, 68100 Batu Caves, Selangor Darul Ehsan, Malaysia.  
Tel: 03-6189 9832 Fax: 03-6189 9336 Website: [www.tcie.com.my](http://www.tcie.com.my)

**Branches:** • Batu Caves Tel: 03-61891896 • Bukit Mertajam Tel: 04-5381308 • Ipoh Tel: 05-2921028  
• Johor Bahru Tel: 07-3538808 • Klang Tel: 03-31669609 • Malacca Tel: 06-3366957 • Sabah Tel: 088-499228  
• Sarawak Tel: 082-488811 **Authorized Dealers:** • Combine Motor Sdn Bhd Tel: 03-61363060  
• Commercial Junction (M) Sdn Bhd Tel: 07-4333998 • Derchin Auto Sdn Bhd Tel: 07-3864108 • Edaran Setia Auto Sdn Bhd Tel: 09-5162288 • Kee Huat Auto Sdn Bhd Tel: 04-6265031 • LK Utara Auto Sdn Bhd Tel: 04-7339098 • Taycn Kredit Sdn Bhd Tel: 06-6787760 • Zep-Zhuan Trading Tel: 09-5676066

quite interesting. Pittsburgh is another one; in certain cities the legislatures are making it more accessible. Google is in Pittsburgh doing a lot of testing on vehicles right now; they are slowly expanding in the downtown area with their own X-Y corridors.

**Q: So do you see challenges with connected vehicles – vehicle to vehicle, vehicle to infrastructure – as all these are still evolving?**

Schutt: They are evolving. The data that needs to be communicated between the two are all well understood to marry the technology that comes into it like 5G. We have developed a digital range of communications which is fast enough and the latency small enough to address communications across all protocols; and with 5G would allow greater connectivity to a more distributed network.

**Q: But here comes the security challenge as the data transfer to different points, and vice-versa, would put the OEMs in a tricky situation as to who owns responsibility. What is SAE's view on this?**

Schutt: Where the liability falls would ultimately be on the lawyers and regulatory framework. We anticipate it would fall down to the components, the OEMs that assemble a whole range of them. Fleet purchasers would be able to customise which components go into the vehicle, much like in airplanes.

**Q: What is the contribution of SAE in managing these emerging issues?**

Schutt: We provide a platform for the technologies to be shared and tested to bring industry together on a pre-competitive basis to begin buying the safety principles they are working towards. In the long-run I can see us going into testing and validation. The Performance Review

Institute does a whole quality certification programme across the globe. As the automotive industry begins to look at this and quality assurances, we could have some validation programmes in place. The other part is that we are doing some preliminary work in Block Chain, validating information flows. We are also developing standards for components that can self-diagnose and communicate to help awareness of the componentry. This is a multi-industry activity across the automotive and aerospace.

**Q: Would these prognostics be built into the systems and modules that go into developing components?**

Schutt: As the design of these gets more mature with the whole discipline of how awareness comes into place, self-awareness would get built into this componentry.

**Q: Every vehicle whether bus, truck or passenger car has innumerable sensors. Their need to communicate puts an immense load on the ECU (Electronic control unit). If prognostics come into the systems and modules, will it not add to more complication in the vehicle architecture?**

Schutt: It will, but it would begin to build in reliability. One of the things we see is that a lot of the protocols and approaches the automotive industry has taken are increasingly applicable in aerospace, and vice-versa. If you look at these really complex fighter jets, they really are extraordinarily fast computers. The techniques and technologies of that could now begin going into the vehicle. I am sure the cost of everything will come down over time.

**Q: Block Chain technology can be applied to data transfer and the aftermarket. What is SAE's role in this, using block chain for the aftermarket and OE?**





**MANN  
FILTER**

# From the first mile to the last.

MANN-FILTER – for first fit and the automotive aftermarket.



Visit us @  
Booth A07 & A17

**MCVE**  
MINES CONVENTION  
CENTRE (MIECC)  
20-22 June 2019

MANN-FILTER, the premium filter brand of the automotive aftermarket, offers innovative solutions to new, challenging filtration demands. As original equipment or yellow-green boxed, whether for passenger cars, commercial vehicles or off-highway applications: original MANN-FILTER products in OE quality are trusted around the world. Always choose original MANN-FILTER in 100% OE quality!

MANN-FILTER – Perfect parts. Perfect service.  
[www.mann-filter.com](http://www.mann-filter.com)



Schutt: We are looking at developing methodologies of validating data protocols and transfers. When I walk into a garage all information on the components of the vehicle, and their health awareness, should be immediately available. In a fleet the block chain can be used to convey all information on requisite components to the OE, garage or anyone down the chain who requires it. Here we are looking at different risk registries and standards.

**Q: The entire world is working on e-mobility, considering environmental regulations. New things are also coming in like fuel cells. Has SAE undertaken any specific work on fuel cells?**

Schutt: I am not very familiar with our standards down at the fuel cell level but we do have different groups working on fuel cells and alternative power sources. Most of the work at present is being done in the US on standard levels for the electrification of batteries.

**Q: The technologies coming into batteries today is similar to what is happening on cell phones; within a month it is obsolete. Fast changes are occurring in batteries.**

Schutt: We have over 27 committees right now working on batteries, with one committee overseeing all. The complexity of the battery warrants adequate standardisation so they are trying to move quickly and efficiently through this; they multitask and spread it out.

**Q: It appears to be endless; some development or the other seems to be always creeping in with people talking about cobalt, sodium and lithium. Where do you draw the line?**

Schutt: That's really a business decision, when you feel, as an OE, that the manufacturing process is good enough and reproducible. Technology will always keep coming in and developing. We have to keep up with it. SAE is not on the business side to define what the right answer is.

**Q: Can you tell us about SAE's upcoming collaborations with other organisations?**

Schutt: All of the standardisation takes place on a global stage. We coordinate with many of the standards bodies around the world. We work a lot with China,

with DIN in Germany; we do have some projects with ISO where we work with the WP-24. Wherever the work is being done and processed, we try to play our part in that process.

**Q: Would you be looking at expanding SAE membership in different countries?**

Schutt: Certainly. Membership to us is an important aspect but my main objective is to get a set of experts, wherever they are, to participate in the process. We engage almost 60 000 people every single year in our standards process; we have the best experts from around the world.

**Q: What is the role of SAE India in supporting SAE International?**

Schutt: I think it's an extension of what we do here, as a partnership. Our pre-professional education programmes are localised to be effective and efficient all over India. We bring in the best talent to develop the paperwork. In the area of standards there has not been a lot of intentional work, at least that I am aware of. SAE is doing much work on student competitions; they follow the same rules, the same spirit. 



# Firama



## ENGINEERED FOR RELIABILITY



### FIRAMA ENGINEERING BERHAD

📍 Lot 714, Batu Lima, Jalan Kuala Pilah, 70400 Seremban, Negeri Sembilan, Malaysia.

☎ Tel: +606 - 6772623 Fax: +606 - 6777979

✉ Email: [yeohsk@firama.com.my](mailto:yeohsk@firama.com.my)

# Malaysia Commercial Vehicle Expo 2019 Breaks Records

*With further enhanced fringe program and an influx of new exhibitors, Malaysia Commercial Vehicle Expo 2019 writes history again and consolidates its position as largest exhibition dedicated to the commercial vehicle industry.*

The anticipation for the event was palpable whenever industry players gathered and finally the show arrived with a lot of highlights to report. Themed "The Future of Transportation in Malaysia", the fourth instalment of the exhibition further highlights the importance of commercial vehicles to move the nation.

## Fully Booked

Event organiser Asian Trucker Media proudly reported that there has been an increase in bookings for space for this year's exhibition. "Not only have we received more bookings compared to the previous exhibitions, but we actually sold out all space available. There were even requests for space that we could not accommodate anymore," said Stefan Pertz, representing the organiser. It was learned that Asian Trucker Media is considering opening up more exhibition space for the 2021 exhibition to accommodate more exhibitors.

## More to Learn

Several exhibitors used the opportunity to engage with the industry during the show. Discussing future trends, Volvo hosted a seminar with the topic "Road to Electromobility for Malaysian Transport Industry". Filtration expert Hengst welcomed delegates to learn

more about how filters work, what to look out for to spot counterfeit filters and what is the best practices when servicing filters. Others took to the stage to present papers, new products or to share information.

## Networked Throughout

Following feedback from previous shows, the organisers amended the networking platforms at MCVE 2019. "This time, we are offering networking opportunities throughout the three days. This is different from the last events where one specific event was meant to connect delegates and exhibitors," said Pertz. In addition, the Hour of Power created a buzz throughout the event. Several exhibitors were given time slots during which they could "make as much noise as they want" in order to attract attention to their booth.

## Upcoming MCVE 2021

While the exact date has not been confirmed, the next instalment of the Malaysia Commercial Vehicle Exhibition will take place in Q2 of 2021. Companies interested in taking up space or sponsoring the event are encouraged to make their bookings early in order to avoid disappointment. **T**







Fifth Wheel Coupler

King Pin

Landing Gear



ALL KIND OF WINDSCREEN FOR TRUCKS & CARS



Hydraulic Tipping Hoists

Edbro
Leading the market with product developments ever since 1916
Member of JOST-World



HYDRAULIC PUMP



Iso Gear Pump

Bend-Axis Pump

Buffalo Mobile Batching Plant Uses JOST Landing Gear & TTK Trailer Component





## Moving Fuels Safely in East Malaysia

*Spending time with transporters in East Malaysia, Stefan Pertz learns more about what it takes to provide safe transportation services of petrochemical products.*

It is a rainy morning in Kuching. Even more reason to be extra careful. We are hopping into a truck to get a feel for the environment in which transporters operate here. Although the streets are virtually empty, our trucker is highly alert. "Safety is important when you move gases." What stands out is that the truck Patrick anak Tadong is piloting is spotlessly clean. Arriving at the depot of Min Soon Transport Company Sdn Bhd, Calvin Chong, the Managing Director, welcomes us.

Asking Chong about his business, he explains that "Currently, we are 100 percent focused on gases transportation, and we are the largest hauliers of gas (approximately 25 000kg per day) in East Malaysia. We distribute all sorts of gases, such as industrial gases and medical gases." As each gas requires different handling, the company has highly specialised trailers to pair with their fleet of 22 trucks. It is this specialisation and the track record when it comes to safety that has led the gas suppliers such as Shell Gas, Mygaz and Linde EOX to outsource the transportation part of the business. "Among the few things that we would like to highlight is that we are the Bronze winner in 2015, Silver for 2016 and 2017 for the CICM (Chemical Industries Council of Malaysia) Safe Road Award," Chong elaborates. One of Min Soon Transport Company's core values is safety. In addition to winning road safety awards, the operation is also certified according to ISO 39001:2012, which is specific to road transport safety. "I believe at the time of certification two years ago, there was only one other company that has achieved this."

In order to achieve such a high level of safety requirement, the company had to make some massive changes. Chong explained that some parts of the business had to be completely re-engineered, procedures re-thought and in extreme cases, certain aspects of the company had to be shut down. "A crucial part of this is the driver selection though." Initially, the management faced resistance when the new system implementation resulted in more work and the procedures took up extra time from the drivers. After getting a good control on driver working hours to reduce the risk of fatigue, Chong moved on to install cameras inside the cabs and outside the trucks to further strengthen the safety aspect.

Some of the issues that Chong is highlighting are road conditions and weight regulations. Apparently, there is still a difference between East Malaysia and Peninsular when it comes to the permissible weights. Road conditions impact the business as the maintenance cost increases if the roads are not maintained properly.



"Growth potential is very limited. The goods we transport have a very steady demand. Year on year, we only see an increase of about one percent. That means our profitability improvement needs to come from streamlining the operation and becoming more efficient."

To ensure safety of the vehicles, Min Soon Transport Company engages Volvo for the truck repair and maintenance through the Volvo Service Planning System. "We don't have an in-house workshop, we rely on Volvo to take care of the fleet maintenance," Chong said. In his view, one has to be specialised and excel in a niche. However, in order to ensure safety on the road, Chong explains that it takes two to tango. "Taking over the business from my father, I enjoyed the challenge of offering a service that is better than anyone else's. We have





to strive to provide the best, safest possible solution. That in turn requires clients that support this belief. You cannot achieve this level of safety with clients that simply look for the cheapest offer. Safety is a cost, yes, but it is also something the one can leverage on to build the brand." Adding to this, he said that the support network from the truck manufacturer is crucial. Although new trucks are less prone to breakdowns, he is having peace of mind, knowing that any issue will be dealt with swiftly and in a professional manner.

On a personal level, a highlight in his career so far has been the injection of four gas tankers in 2016 as a result of the company's expansion.

Hopping over to Kota Kinabalu, just a two-hour flight away, we also met with Rusman Bin Japalus, Managing Director of Kotamas Oil Sdn Bhd (KOSB). He

proudly shows us the yard, on which several trucks have been parked. "We are very proud of our achievement as we started with just one truck, a Japanese one. We still keep it as it has sentimental value," he said. A true family business, run by three brothers and incorporated in 2005, the principal activity today is the transportation of petrochemical products for reputable oil and gas companies in Malaysia.

Aiming to be the preferred haulier for the oil and gas industry, he also aims at 100 percent on-time delivery, without any accident or incident. Having grown to an organisation, operating in four locations in Sabah, namely Tawau, Kota Kinabalu, Sandakan and Labuan, the fleet now boasts a total of close to 100 trucks. Of that, some 30 units are Volvo trucks. The choice for Volvo trucks was made based on the recommendations of oil and gas companies. "We are proud that KOSB had been recognised as one of the reputable transportation companies in Borneo. Also, our driver has been shortlisted as the 2015 Volvo Malaysia Fuelwatch finalists, and won the third place".

When asked what spurred the rapid growth, Rusman says that one of his strength lies in his prior knowledge on handling of heavy vehicles and cooperation between the drivers, staff and the client. "Prior to this, I have been working in an oil and gas transport company as a driver, where these things are very important. I applied this to the transportation business when I started this business venture with my two brothers." When it comes to working with family members, he cautions that one has to be able to separate work and private life. "Especially when it comes to matters concerning safety, personal matters cannot impact business related decisions."

Citing the HSE requirements, Rusman says that the guidance of their clients have helped shape up a safe working environment. "I did not want to stand still by working on salary basis and here I have a chance to shape the future of not just the family, but also of our staff." Staff has been supportive of the initiatives and employees are working alongside the management team to improve safety. "The important issue is how the leaders behave and how they value safety," he quipped. Those that cannot comply with the strict regulations will usually quit themselves, as they are not aligned with the company's vision.

KOSB strongly believes that innovation helps to boost productivity and efficiency. They have been the pioneer in Malaysia to use the Volvo FMX 6x4 with tandem axle lift. Through this, the fuel and tyre consumption have dropped by some 15-20 percent. When lifted up, the axle automatically dis-engages. "While this is certainly a very expensive add-on, the benefits are even greater. While the trucks comply with the requirements of our clients, we manage to reduce cost without compromising safety. We are very happy with the trucks, and intend to add few more units into the fleet." 





## CAPAS 2019 Opens Big

This year's edition of CAPAS was held from the 23rd to 25th May. With an event space of 48 000 sqm comprising of 612 domestic and overseas exhibitors, CAPAS 2019 showcased the promising automotive market of Southwest China. Visitors totalled 18 916 this year, which is around 5 percent increment compared to the last edition.

Ms Fiona Chiew, Deputy General Manager of Messe Frankfurt (HK) Ltd commented on the highlights of this year's CAPAS. She said that "Our deep understanding of current policies and consumer market demands in Southwest China enables us to present the rising trends at CAPAS. The fringe programmes is also set to discuss the latest strategies for overcoming operational challenges. Visitors can sit in on many concurrent conferences, training opportunities and engage in a number of themed activities. In addition, various business matching services will improve overall sourcing efficiency by enabling visitors to find the right type of exhibitors."

Additionally, Vice President of the China Council for the Promotion of International Trade, Sichuan Council (CCPIT-Sichuan), Ms Wang Li commented on the role of CAPAS in China's automotive industry. "CAPAS is able to utilise its position and support the development of China's "5+1" modern industrial system by creating opportunities to match local industry needs, as well as bridge communication between manufacturers and parts suppliers in the Sichuan region. The fair continues to deepen its integration of 'Trade Fair, Industry, Functional Zones and Investment Promotion' by accelerating industry development. In fact, 14 developing cities including the likes of Guang'an, Nanchong and Yibin have joined this year's fair to present their local advantages to attract investment."

CAPAS continued to improve its sourcing efforts by enhancing its themed zones and categories. The seven themed zones for this year included Parts & Components, Commercial Vehicles, Accessories & Customizing, Repair, Supply



***The 6th edition of Chengdu International Trade Fair for Automotive Parts and Aftermarket Services (CAPAS) kick-started at the Chengdu Century City New International Exhibition & Convention Centre in China. Carol Yeoh went to scoop the latest from the event.***

Chain and Chain Stores, E-mobility & Infrastructure, Made in Sichuan and a Tyres sector. Prominent exhibitors across these zones include Adient, Chuannan Absorber, Hengst, i-Reach, K&N, KenBaoJie, Knorr-Bremse, Modify-ah, Petro-Canada Lubricants, Ruili, SATA, Shudu Bus, Snap-on, WABCO and Weltmeister.





This year's edition of CAPAS strived to provide more detailed and personalised services, all whilst upholding the show's mission to support the industry growth in the Southwest region. The exhibition provided a series of visitor promotion activities and seminars in promising Sichuan cities such as Chongqi, Meishan, Suining and Zigong. As a result, CAPAS 2019 saw a 20 percent growth in buyer group participation, with many hailing from repair workshops, fleet and logistics service backgrounds.

The newly launched Business Matching Service for VIP Buyers saw great results at CAPAS 2019. Through their keen knowledge on the specific sourcing needs, the dedicated CAPAS team were able to match buyers with exhibitors based on their mutual requirements. The programme managed to boost the success rate of business deals. Director of Sourcing, Mr Zhang Hua from Wuxi CRRC Hofer Powertrain Co Ltd said that "Sichuan and Chongqi are two key manufacturing bases in the nation, whilst the new energy vehicle market is experiencing a robust growth under the government's support. Our company has been supporting

The manufacture of new energy vehicles and smart vehicles form one of the 16 developing industries in Sichuan. As such, the E-mobility & Infrastructure Zone played an important role in CAPAS. The zone gathered key players and suppliers for new energy vehicles from Sichuan and across China. The zone also welcomed the new Hong Kong Pavilion for New Energy Vehicles. Led by the Automotive Parts and Accessory Systems R&D Centre of Hong Kong, the pavilion hosted 24 technology-based companies from Hong Kong which showcased green logistics, material and manufacturing products, as well as smart technology and mobility.





the integration of new energy automotive powertrain systems by Hofer and CRRC. We came to the fair to source new parts and systems for the powertrain. The business matching service provided at CAPAS is truly appreciated as it drove more meaningful business conversations."

In addition to relevant topics being discussed during the fringe events, Knorr-Bremse had a Commercial Vehicles Job Fair for China Trailer Service 2019. CAPAS was definitely the right platform to hold a job fair as all those interested in the commercial vehicle industry would not miss out of the opportunity to visit the fair. The job search saw great results and many individuals were present on that day.

CAPAS is jointly organised by the China Council for the Promotion of International Trade, the Automotive Sub-Council (CCPIT-Auto), Messe Frankfurt (Shanghai) Co Ltd and the China Council for the Promotion of International Trade, Sichuan Council (CCPIT-Sichuan).

#### **Exhibitors in Focus at CAPAS 2019** **Index Sensors & Controls Inc**

Index Sensors is a leading manufacturer of switches, sensors and controls for commercial trucks, engine, agricultural, off-road and industrial equipment markets.

For over 40 years, Index has built a reputation for designing and producing products that can withstand harsh environments. Index is a supplier to some of the world's most demanding equipment manufacturers including Cummins, Caterpillar, John Deere, all makes of Class 8 trucks and a wide range of specialty original equipment manufacturers (OEM). The company is a Tier 1 OEM supplier to over 50 engine and vehicle producers.

Index's sensors and switch manufacturing facility and headquarters are located in Bellingham, Washington. Constructed to LEED Gold standards, the building was designed to support Index's advanced engineering and quality labs, world-class manufacturing processes, flexible layout, effective inventory management and advanced computer information system. Index maintains an industry leading 2-week turnaround for standard catalogue items with a 99 percent on-time delivery rate.

On why the company is at CAPAS 2019, Greg Colburn, General Manager said that the company is trying to expand its brand awareness. "CAPAS is an ideal platform to spread our brand awareness in China. The exhibition brings in many key players of the automotive industry and allows us to gain exposure. As we are OEM to many brands



such as Cummins, Daimler, Volvo, Mack and many others, most people are not aware that they are using our products."

Since 1976, Index has continued to expand its focus on helping industrial vehicles and equipment OEMs and users to add innovation and efficiency to their products. Index's switches, sensors and controls play a vital 'behind-the-scenes' role in improving basic machine operation as well as benefit equipment users with ease of operation, diagnostics and lower maintenance costs.

#### **Changzhou Freecars Auto Parts Co, Ltd**

Changzhou Freecars was established in 2002 and specialized in the manufacture of lamps, bumpers and other parts. The company puts in tremendous effort into researching, developing and manufacturing parts for truck brands such as Volvo, Scania, MAN, Renault, Mercedes Benz, Iveco, Isuzu, Hino, Mitsubishi, Foton, Howa, Dongfeng etc.

Since its inception, Freecars has aimed to provide quality products at an affordable pricing. Therefore, all products made by Freecars are compliant to OEM levels. In order to enter the European market and expand their business, the company was E-MARK certified. In 2008, Freecars collaborated with Russian logistic and local companies to obtain the GOST-R certification to allow exportation to the Russian market. In order to further attest to the quality of its products, the company in 2011 received ISO/TS 16949:2009 certification.

The company has attended many exhibitions in order to spread brand awareness. Some exhibitions the company has attended include Automechanika Dubai, Sao Paulo Auto Parts Exhibition, Iran International Auto Parts Exhibition, Automechanika Shanghai, Automechanika Istanbul and Moscow MIMS Auto Exhibition amongst many others. A representative of the company shared that they are in the midst of expanding the business in the Southwest region and decided that CAPAS was the right platform to do so.

"CAPAS is very concentrated on the Southwest China region and as we are in the midst of expanding our presence in this part of the country, we decided to join this year's edition. As our headquarters is in Changzhou City, Jiangsu, we were always concentrated on that region. Although we have a





branch in Guangzhou, we are relatively unfamiliar with this part of the country. Therefore, we have come to CAPAS to make some friends from Chengdu and hope that some sort of collaboration can result from this three day show” said a spokesperson from the company.

**Knorr-Bremse**

Knorr-Bremse AG is a German manufacturer of braking systems for rail and commercial vehicles that has operated in the field for over 110 years. Knorr-Bremse has been developing and manufacturing braking systems for commercial vehicles since 1920. The company has a presence in over 30 countries at more than 100 locations.

Knorr-Bremse’s commercial vehicle unit offers braking systems for trucks, buses, trailers and agricultural machines. The company is a leading provider of electronic brake control systems, driver assistance systems as well as air treatment; making a key contribution on road safety. Other products include powertrains and vibration dampers for diesel engines. The Commercial Vehicle Division of the company posted sales of EUR 2.93 billion with a workforce of over 11 000 employees.

Over the years, Knorr-Bremse has established itself as a vital and committed brand in the Chinese market. The company currently has operations at 13 locations in China, including the Asia Pacific headquarters in Hong Kong, employing around 5 000 employees.

A wholly-owned subsidiary in Suzhou supplies brake systems while five joint ventures located in Wuxi, Qingdao, Nankou, Daxing and Jiangmen supply brake, door and HVAC systems. Opened in 2016, the Suzhou base functions as a production facility and a testing centre. A Shanghai based wholly-owned subsidiary serves as the headquarters of the Commercial Vehicle Systems Division in China; providing sales, marketing, application engineering and global sourcing services. Moreover, the division also operates a wholly-owned company in Dalian and two joint ventures in Chongqing and Shiyan to supply a range of commercial vehicle brake products.

According to a representative of the company at CAPAS 2019 “China is a very important market for Knorr-Bremse. As the economy of the country increases, so will the demand of our products. We are here today to let people know of the quality of our products. We acknowledge that while the price of our products may not be the cheapest, we do not compromise on quality, and we want our consumers to know that. Knorr-Bremse invests a lot of money into the research and development of our products and users can rest assure that the products that they use are of the highest quality. Our users search for quality, they know that the products they buy from us will definitely last which is why they are worth investing in. In recent times, we see more Chinese consumers using our products. They have come to realise that cheaper products seem to incur more maintenance or replacement costs.”

On the production of their products, the representative shared that whilst most of their products are made in China, some specific parts are made in Germany to ensure that quality is not compromised. “Most of the technology and machines needed to make our products can be found in our Chinese factories, but some machines are too costly to be shipped over and therefore those products will be made in Germany then shipped over to China. This way we can keep costs lower for our consumers while still maintaining the quality one would expect from Knorr-Bremse” he concluded. **F**









# Steelbro's Latest Sidelifter Offers the Best of Both Worlds



Operators wishing to transport and deliver lighter loads more economically may find this new model becomes their first choice. Simply put, the design seamlessly combines the very best of both worlds – low tare weight and proven strength and durability in one unit. Faced with two competing yet important design objectives, Steelbro set out to produce a sidelifter that met the optimum needs of low tare weight, while at the same time delivering proven strength and durability.

The SB362 has been tried and tested in New Zealand and Australia where it enjoys a strong presence in the commercial road transport market. For some years the SB362 has become a top selling product in those countries. Many operators approve of the technology and have been impressed by its performance, e.g. having the ability to lift up to a 36-tonne weight yet answering the payload challenge.

With a 36-tonne lifting capacity, the sidelifter is quick and stable and boasts an outreach of more than four metres to provide ease of operation. The SB362 is available with a separate power pack system with Kubota engine. This means that the sidelifter can operate with any truck without any specific hydraulic fittings, and gives more flexibility for operators with a fleet of trucks. In addition, this model will handle 20 foot containers, 40 foot containers as well as 2 x 20 ft containers side by side. It will also handle the double stacking of containers, an added feature when space is at a premium.

*Steelbro is excited to introduce the SB362 sidelifter to the Malaysian market. This new model customised for Malaysia, gives transport operators a new option in sidelifter technology.*







Although based on an existing successful design, the SB362 you will see in Malaysia has been carefully modified for the Malaysian market. Steelbro designers gave this customised unit a heavy-duty chassis to cater to the Malaysian environment and conditions. The design uses similar running gear to the already popular Steelbro model (SB450) for seamless integration with other units in the fleet. Sidelifters are also JPJ and DOSH compliant.

The New Malaysia model is not expected to replace the SB450 unit, but will offer an alternative choice, and in some cases supplement the existing fleet. According to Steelbro, operators are still expected to choose the SB450 when conditions are extreme and call for a more rugged sidelifter unit with a stronger lifting capacity. With the SB450, transfers of containers weighing up to 45 tonnes can be made easily within a safe working envelope.

Operators who include both models in their fleet will benefit from similar running gear on the chassis



for ease of maintenance and spare parts. In addition, both the SB362 and the SB450 utilise the same controller, cable and remote which means that no additional operator training is required.

The Malaysian team is excited to launch this product into the country. Steelbro SE Asia Regional Manager, Andy Ersalle says, "Steelbro Malaysia strives to exceed the expectations of our customers as we now offer a range of options in the sidelifter product line i.e. units for both heavy duty use and regular use to meet customer demand. The new Steelbro SB362 sidelifter for regular use is being introduced at a competitive market price offering great value without compromising with quality. This long-awaited model to the market, for small and medium size industries is expected to deliver cost reduction savings for our customers as well as being capable of delivering a safe working load of up to 36 tonnes. It's one of the best valued sidelifters in the industry designed with safety and stability in mind as well as offering a long service life."

Steelbro will be at the Malaysia Commercial Vehicle Expo (MCVE) in Kuala Lumpur from 20 – 22 June 2019 and the team looks forward to demonstrating the features of this new sidelifter. 

ASIAN TRUCKER DRIVERS CLUB

# UPDATE



PREMIUM SPONSOR:



Shell  
**RIMULA**  
Heavy Duty Diesel Engine Oil





# ASIAN TRUCKER

## 2019

**SHELL RIMULA**  
Trucker of The Month



[www.asiantrucker.com](http://www.asiantrucker.com)

## BE SHELL RIMULA Trucker of the Month!

Send a picture of yourself with Shell Rimula products and tell us why you should be our TRUCKER OF THE MONTH.

Win attractive prizes!

- Rimula Mug & Shirt
- Limited Edition: Rimula Condotti Luggage
- Asian Trucker Shirt, Cap, Sticker & Sleeves



**Shell**  
**RIMULA**  
Heavy Duty Diesel Engine Oil

Send your entries to

 [info@asiantruckerclub.com.my](mailto:info@asiantruckerclub.com.my) OR  Whatsapp: **017-232 8451**  No. 27-1, Block C,  
Zenith Corporate Park, Jalan SS7/26  
Kelana Jaya, 47301 Selangor



## A Stress-Free Lifestyle as a Trucker

**W**ith many job experiences under his sleeves, Sanusi Hasan decided to become a truck driver 17 years ago to get away from rigid office restrictions and regulations. "It is a job with very little pressure," he said. The 40-year-old from Terengganu has been driving cargo trailers for the GS Express company for four years.

Before that, he has worked as a marketing executive, factory supervisor, factory line leader, factory quality control, bonded truck driver, petroleum tanker truck driver for Petronas and a pallet truck driver, also for Petronas.

The best part about being a truck driver, he said, is that it is stress-free. "It also has an easy standard of procedure (SOP) and I get to go to and see so many places around Malaysia. That is something I could not do if I was confined in an office every day. Now, not only do I get to travel, but I am also getting paid to do it," Sanusi said.

All that "fun" however comes with a price. His least favourite part about being a truck driver is, when driving in the city, he is always stuck in traffic jam. "Heavy trucks always have to give way to the smaller vehicles and this delays us much further. So, I have to be really smart about arranging my time in terms of hitting the city roads." Although that is the worst part about the job, Sanusi never let it get the best of him. His thoughts are always on his wife and three children who keep him going. "They support me although driving trucks is not seen as a glamorous job. They keep me happy and encourage me to do the best every day," he added.

As much as he loves his job as a truck driver, Sanusi may not want to do it forever. "I dream of starting my own business one day. I do not know what the nature of business is yet, but it would be great to work for myself. It would be something I can leave behind for my children."

Sanusi was recently picked as one of the winners of the monthly Shell Rimula Trucker of the Month contest. As an experienced truck driver, he had used



**Seventeen years as a truck driver, Sanusi has very little to complain about.**

many different engine oils, but Shell Rimula products are indisputably the best for him.

"Truckers are a small community and when we get together and change notes about our trucks, most of us agree that Shell Rimula products are among the best in the market. It is very important for us to use excellent products because we demand a lot out of our trucks where mediocre brands are not an option," he said. **T**



# Driving into Sunset

**M**ohd Zameri Bin Rosli is 38 years old and comes from Pahang. Zameri has been with Nittsu Transport for eight years. "It is great working for Nittsu. I have been working with them for eight years and I do not foresee myself leaving anytime soon. My colleagues and I get along very well and we have fun whenever we clock in for work" said Zameri.

Zameri shares that while working as a truck driver, he has had many opportunities to travel around the country. His favourite route is along the North-South Expressway which boasts some amazing scenery Peninsula Malaysia has to offer. Zameri described the sunsets along the route to Ipoh as one of the must-see sights in Malaysia. As a major artery that links Bukit Kayu Hitam in the northernmost part of Malaysia to Johor Bharu at the south, the NSE spans a length of 966km and provides a vital transportation link to towns on the west coast of Peninsula Malaysia.

Before leaving for any assignments, Zameri always makes sure to check his truck to ensure that it is safe for travel. Zameri checks for any visible damage, tyre pressure and lubricants amongst others. "It is our duty to check our vehicle before we leave the depot. We try to minimize any risk of accidents to make our roads a safer place for all road users. I think all road users should check their vehicles before starting the journey. This also reduces any downtime and goods can be delivered on time which is important for our clients"

Zameri also shares that "our company has always been using Shell lubricants for the trucks. I have a good impression on Shell products as they always deliver quality products. The lubricants allow for engine optimization and allow for a longer service interval. I am glad my company chooses Shell as their lubricants of choice." 

*This trucker enjoys his job as a trucker and tells Asian Trucker about his adventures.*



Zameri is our Shell Rimula Trucker of the month.



over three different depots, with all the trucks moving all over peninsular Malaysia. Once the company starts to lose track of their tyres, it could cause quite a havoc.

Kenneth Teh also mentioned that tracing truck tyres is crucial for a few reasons. Firstly, the fleet owner needs to keep track of the tyre tread usage versus mileage used in order to calculate the actual cost per kilometre so that they can decide better on which tyre to use in order to cut down their operations cost further. The fleet owner also needs to count the stock periodically to ensure there is no fraudulence among their maintenance team and drivers. For stock level maintenance, if there is any shortage, it will cause business operations to halt. Trailers might go back and forth between the custom’s warehouse and the customer’s warehouse again and again that they do not return to the maintenance depot for months, putting a lot of pressure to the tyres. When travelling long distance, the heat will start to build up and kill the tyre, resulting in lower mileage for the tyre and higher cost per kilometre.

Traceability for truck tyres has always been a challenge throughout the years for fleet operators. By not managing it well, you will suffer damages including but not limiting to missing tyres, mud guard and chassis damages, operation downtime and so on. These losses might not be obvious in the short term, but in the long run it will take a hefty toll on your cost and limit your business potential.

With the advancement of technology nowadays, fleet operators can implement more solutions towards ending this frustration and confusion. Current GPS software used by fleets can only track the location of the prime movers or trailers, not the location and condition of the tyres. There is a need for a tyre management solution in the market and Kit Loong Commercial Tyre Group has successfully developed a total tyre management system known as KLconnect TTM+, consistently upgrading it to better cater their customer base with the aim “to monitor and maintain the health of every tyre in commercial fleets”. To date, with their know-how and KLconnect TTM+, Kit Loong is managing around 40 000 wheels on the road and generated more than 120 000 tyre health reports since the year 2017. **▮**

## Traceability and “Health” Issues for Commercial Tyres

*Kenneth Teh of Kit Loong Commercial Tyre Group shares insights and solution on how to manage tyre traceability for both, truck and in stock.*

**T**yre cost has always been both confusing and frustrating for fleet operators. By the end of the day, the cost variances fluctuate tremendously, and no operator can control their tyre cost consistently within 10 percent marginally by month or by year.

In order to control tyre cost more efficiently, tyre traceability which is always a big administration works plays a big role. The whereabouts of a tyre can be difficult to trace and the performance hard to measure throughout the tyre’s life. In order to trace a tyre, we must track from the very beginning of the tyre’s life with all its information (brand, size, purchase date, Installation date, price etc). Once it is installed, the technical traceability recording starts with all the technical concerns (Installation position, injuries, position rotation, take out, repair, retread etc) recorded throughout its life. In the end, if everything is accurately recorded, it becomes a “health report” for that tyre and this can give us useful information in the future.

Confusion happens after the installation where the tyre might be removed for repair and replaced with a temporary tyre. Due to the urgency of the transportation’s business operation, the truck tends to continue moving, leaving the swapped tyre behind. Commercial vehicle breakdowns for tyre related reason will further add on to this tracing problem of swapped spare tyre or replaced new tyre. Sometimes sending a tyre to be retreaded could cause more confusion if everything is not being recorded systematically. Along the way, some tyres go missing as well.

Imagine how many tyres a fleet needs to keep track of. Take for example where a medium size haulage company owns 100 6x2 prime movers and seven trailers to each of the prime mover. That will be 10 tyres for each prime mover, and eight tyres for each trailer (considering that they are all tandem axle trailers). This is already 6 600 tyres on the road (which is like managing 6 600 staff), which is a lot for just a medium fleet running a few hundred kilometres away from home ground. Further including their new tyres and retreaded tyres stock, tyres in transit, tyres being retreaded, and so on, the total amount of tyres owned by a medium size haulage company could easily exceed 10 000. Imagine all these tyres spread





## Two Japanese Companies' Efforts for Safer Malaysian Roads

*Hino and Yamato collaborate to provide aptitude tests and training for Malaysian truck drivers.*

**T**roubled by the high number of road accidents in Malaysia, Yamato Transport Sdn Bhd (YTM) has turned to Hino Motors Sales Malaysia Sdn Bhd (HMSM) to collaborate in a programme that focuses on a driver aptitude test (DAT) in Hino's training facility in Sendayan, Negeri Sembilan.

YTM Managing Director, Takeshi Kitaoka, quoted the Malaysian Institute of Road Safety Research (MIROS)'s study that the main cause of road accidents is human error where people drive recklessly and ignore traffic rules.

"This human form of error can easily be helped and curbed through a thorough driving aptitude test that would aim at minimising human error and making Malaysian roads safer," he said during the launch at the Hino Total Support Customer Centre (HTSCC). Practiced in Japan since 1972, it became mandatory for commercial drivers to take the DAT which is the main measure for reducing the number of traffic accidents.

"At Yamato we use this aptitude test to evaluate our employees and provide appropriate training to our drivers. In 2004, we became the first privately-owned company to be approved to execute the DAT," Takeshi added. The aptitude test utilises the outline of DAT that would help drivers determine their level of skill under Yamato's repetitive tests. The series of results within the DAT would help to determine a driver's skill and keep the results in line with standard road safety levels.

"After going through the test, our instructors will provide feedback on how the drivers can manage their behaviours and attitudes based on their results. Drivers will be able to realise the problems of their driving and what they need to improve on to drive more safely," Takeshi said.

The training programme provided by HTSCC includes safety-related content using a combination of driving aptitude diagnosis, training lectures, and vehicle training. The training is based on each driver's driving characteristics, with the aim of further improving their knowledge, awareness and driving skills for safer driving. Specifically, instructors use the results of qualitative driving aptitude tests, and give awareness through quantitative on-the-job training, as well as facilitate improvement in their knowledge and consciousness of safe driving. In addition, training results are shared with the drivers and business operators as an aid to their daily safe driving guidance.

Contents of the training programme include a pre-theory test, aptitude test, analysis of aptitude test and consultation, lecture for safety driving (human characteristic and characteristic of vehicles), safety driving session and a post-theory test.

HMSM Managing Director, Atsushi Uchiyama, said the training programme reflects Hino's emphasis on Total Support, Hino's original concept where it emphasises on "caring for our customers' business" and aiming to contribute to their business needs and success.

"As part of the Total Support concept and contribution of our Corporate Social Responsibility, Hino takes the opportunity to collaborate with YTM where we together created a holistic approach to develop higher number of competent truck drivers in Malaysia."

"Hino and Yamato endorse this collaboration as we comprise the same concept and direction to contribute to Malaysian society through safety programme for truck drivers. The DAT by Yamato will enhance the training programmes in HTSCC as throughout this test, drivers are able to identify their level of driving skill and will go through the practical driving training conducted by Hino," Atsushi said.

He also said that with this aim and initiative, Hino and Yamato aim to be in line with the government's efforts to reduce the number of heavy transport accidents on the road. "And together with Yamato, we aim to contribute to the development of the economy, welfare and human life in Malaysia by aiming to stabilise and reduce the rate of road accidents up to 50 percent by 2020," Atsushi added. **F**

# Real-time driver fatigue and distraction prevention Technology



*Guardian is proven to reduce fatigue events by more than 90 percent*



**D**riving while fatigued and distracted is a major road safety issue in Malaysia, particularly among truck and bus drivers. Shift design, individual driver behaviour and workload design are all contributing factors in potential fatigue and distraction related accidents.

Currently there is an average of 209 fatalities per year which involve a lorry. This number of road accidents has shown no significant reduction over the past 10 years and with an increasing number of fleets in the country, more technology solutions are needed to address this issue.

According to the Malaysian Institute of Road Safety Research (MIROS), 81 percent of road accidents were caused by human negligence. This figure includes fatigue and distraction which impair a driver's ability to react to potential road hazards.

Besides the tragic nature of injuries and loss of lives, road accidents result in significant cost burdens to the community, and especially governments. Depending on the severity, road accidents may result in costs ranging from RM 13 000 for a minor incident, and somewhere in the range of up to RM 1 300 000 where serious injury or death occur. Road accident cost covers key components, namely medical costs, lost output, wage risk, damage to property and court awards. Lost output, wage risk and other reflect the potential loss to





drowsiness or distraction in real-time and helps to prevent accidents before they happen. Used by transport and logistics companies worldwide, Guardian has been proven to reduce fatigue events by more than 90 percent. In the past 12 months Guardian has intervened in more than 85 000 fatigue events and since its launch in 2015 has detected more than 4 000 000 distraction events.

## HOW IT WORKS

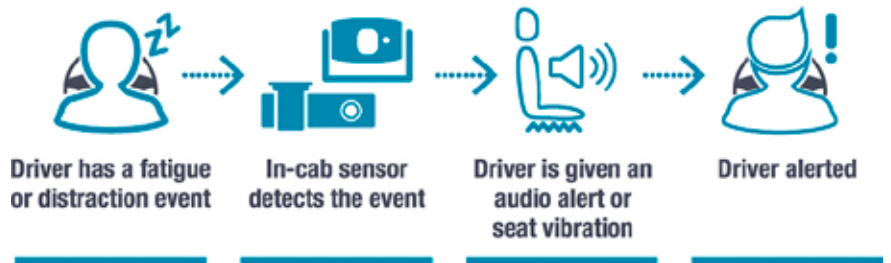

Guardian uses reliable face and gaze-tracking algorithms that measure the driver's head position and eye closure and, when safety parameters are exceeded, audio alarms and seat vibration are immediately activated. Guardian also features a forward-facing camera which captures critical information about road conditions at the time of the event.

When a fatigue or distraction event is detected, data and footage are immediately relayed to Seeing Machines' 24/7 Guardian Centre, where humans analyse each event that is detected and is then able to alert fleet management and allow them to respond in real time to any developing situation in their vehicle. Importantly for drivers, Guardian respects privacy and only sends in-cabin video to the 24/7 Guardian Centre for review if an event occurs. It does not act as a CCTV.

Guardian's in-cabin alerts are supported by the Guardian Live database. Managers are provided access to Guardian Live and can gain further understanding of driver behaviour. Weekly reports help fleet managers to analyse fatigue and distraction events with respect to time of day, the location and speed at the time an event occurred. Guardian empowers fleet managers with data to drive change in their organisation and can be used to positively influence driver behaviour as well as company safety policy. **➤**

the employer and the economy due to productive time lost because of an accident.

In a road traffic accident, damage to property not only includes the damage to the vehicles involved in the accident, but also to roadside infrastructure like lamp posts, railings and trees. Further, there is the threat of litigation which may result in Court Awards to cover road crash victims for non-economic losses as a measure of the quality of life.

Australian company Seeing Machines has developed a camera-based technology which aims to reduce the risks of drowsy and distracted driving, known as Guardian. Guardian delivers a reliable and unobtrusive solution that detects driver





## Hino's Atsushi Uchiyama Transformation Plans

*Quietly, Hino Motor Sales Malaysia welcomed its new Managing Director, Atsushi Uchiyama. In this exclusive interview with Stefan Pertz he tells us about how he will use his past experience to give the brand a boost.*

It has been just over three months since Atsushi Uchiyama, MD, HINO Motor Sales Malaysia, arrived here in Malaysia and we sat him down to get to know him better and to learn about his ambitions for the brand. Growing up in Niigata prefecture, at the age of 18, he moved to Tokyo to study. He discovered his passion for commercial vehicles during his studies. Travelling as a backpacker, he depended on buses to move around and he noticed that many buses in the South East Asian region are supplied by Hino. "When I started to look for a job, I wanted to contribute to the development of the world and I remembered that I have been on many Hino buses when I was travelling and so I applied for a position with Hino." Trucks and buses are part of essential infrastructure in his view and this sealed his decision.

In line with Japanese traditions, he has been a long serving employee of Hino, having joined the Japanese OEM in 2005. He started out in the overseas marketing department. For the first seven years he was responsible for African and Middle Eastern markets. Following that, he embarked on his first overseas assignment in Thailand. For the next five years he was the Sales Division Coordinator. Coming back to Japan, Uchiyama spent the next two years looking after South East Asia, including the Malaysian market. In 2019, he moved to Malaysia to become the Managing Director of Hino Motor Sales Malaysia.

Some customers have already met with him and commented that he seems to be very young. However, this image may be perceiving. "When I was working in Japan and Thailand,





One of the key challenges Uchiyama has identified in Malaysia is the lack of skillful drivers. To tackle this, Hino is making efforts to train more drivers. Another issue that he sees is the lack of first and last mile transportation at MRT stations. In his view, the lack of mini buses for example, is the reason why people still use their cars to drive all the way from home to work. One of the highlights at the MCVE 2019 will be a mini bus that Hino is showing as a possible solution. The other challenge that Uchiyama sees is the provision of sufficient infrastructure to allow for electrification of commercial vehicles. In Japan, trials have commenced and within Hino it is an accepted belief that the pure diesel truck as we know it will disappear by 2050. There is a sense of urgency to address this development and to provide electric vehicles. Again, on behalf of Hino, Uchiyama would like to initiate official talks with the government on this topic.

Overall, Uchiyama would want to transform the market. One aspect is the fact that Malaysia still allows re-build trucks. "I understand that some transporters cannot afford new trucks. However, a re-build truck is already an old truck and is more prone to breakdowns." He hopes that Hino will be able to convince more people to opt for new vehicles as they are more reliable and thus more productive. "It is my challenge that I want to increase the number of service intakes". The challenge, in his view, is not the number of service centers, but the service levels, which need to be professional, consistent and comprehensive. In addition, he is gearing up for Hino to move on to the next level of service delivery. "My vision is that Hino dealerships become one-stop centers". Currently, second hand trucks are sold by specialised third party dealer and vehicles that have been damaged in accidents are being fixed in outside panel workshops. All these peripheral activities are to be integrated into the existing Hino service centers.

At MCVE 2019, Hino will showcase a new model of the Hino 700 Series, updated LCV with automatic gearboxes and the "Poncho", a mini bus that will be suitable to address the issue of last mile transportation for MRTs. **F**

I have always worked with a sense of ownership. I have always tried to aim one or two levels higher than it was expected. In Thailand, my team was 50 staff strong and I learned how to manage teams and departments. I also handled 90 dealers, which taught me how to manage distribution." One of the principles he applied has always been the Genchi Genbutsu (現地現物), which means "Go to the actual site and see what is happening there with own eyes". Seeing the site and actual customer allowed him to gather first-hand feedback and reflect on it. The insights gained would be channelled to the dealers or the headquarters in Japan. "This allows me to understand the dealer's, the customers' and the manufacturers' side." To add to that, he was also responsible for the profit management of the head office distributors.

This year, Hino will add new services to be offered at the Hino Total Support Customer Center (HTSCC). Besides free, basic training, new modules have been introduced to further improve the skills of drivers, such as the night driving course. What makes some of the courses even more attractive for fleet owners is that HRDF is now supporting the training. It is noteworthy that the facilities are open for owners of trucks other than Hino as well, however, training would be conducted using Hino vehicles. "Given that we have these facilities and capabilities, we would like to work closer with the government. For instance, we hope that we can become an approved training provider for MIROS. From now on, we would like to be more involved with the relevant authorities. You may ask why we take an interest in this, but the answer is simple: we want to do our part to reduce fatalities on the road," Uchiyama explains. In addition, he sees accidents, although they may not be fatal, as a hinderance to growth as they cause traffic jams that impact businesses. With the approval of HTSCC as an official training ground, Uchiyama hopes that the number of participants will increase. On the hardware side, Hino is also equipping trucks with the latest safety features. For instance, ABS is a standard feature for LCVs offered by the Japanese brand.

Another major change that Uchiyama is preparing for is the possible introduction of B20 as fuel to the Malaysian Market. He relayed that this information has already been conveyed to Japan and he assures customers that Hino will be ready should this move take place. "I would like to say to customers that they should not worry. We will bring the right product to the market to ensure that customers have the best possible transport solution." In other markets, Hino already has B20 compliant engines.





Scania's construction vehicles derive from their solid history of timeless engineering and extensive field testing in the roughest conditions. A perfectly suited background for an industry that seldom offers the luxury of a well-paved road. If you are looking for that extra durability, tailored flexibility, and robust look, then the XT execution of the New Generation Trucks from Scania might be the right choice. It is supplying a series of powerful features applicable to their entire cab range, chassis, and engine program.



### **Robust XT steel bumper**

The one-piece sturdy steel bumper provides great protection for the front components of your vehicle, reducing unwanted downtime and costly repairs to cab and chassis. In addition, its large approach angle improves your mobility and flexibility at the construction site. The fold-out service step in the bumper, together with grab handles in the front, ensures safe, nonslip access to the windscreen, saving time on daily maintenance.

### **Extra Inspection Step**

The inspection step available on our day cabs provides easy access for checking the cargo or body without stepping down from the cab. Integrated in the cab side behind the door, combined with a handle on the roof and an optional extra handle inside the cab, it provides the best possible ergonomics and safety.

### **Sturdy Towbar**

The XT range features the strongest towing capacity on the market – 40 tonnes. The easily accessible, heavy-duty tow pin in the front enables the vehicle to be quickly pulled out of trouble, even without unloading the cargo.

### **Heavy-duty Powertrain**

With an extremely efficient cooling system, advanced combustion technology, and fuel injection, Scania engines provide exceptional performance with outstanding fuel efficiency, high torque, and low emissions. Together with our extensive range of gearboxes you will be perfectly suited to take

on any task, of any operation. The whole range of Scania heavy-duty gearboxes can be equipped with the Scania Retarder. Use it together with an exhaust brake, and experience greatly improved brake performance.

### **Safety**

- Cab – Swedish crash test standards are among the most stringent in the world, using the same cab for all tests. Our new generation has surpassed them with ease. The new high-tensile steel cab structure offers an outstanding crash performance.
- Visibility – By moving the driver's position forward and sideways, lowering the instrument panel and redesigning the A-pillars, we have improved the direct visibility in the new cab, making your driver feel in control.
- Electronic Stability Programme (ESP) reduces the risk of skidding and tipping over, as well as the effects of understeering and oversteering
- Air bags – Being the first in the industry, the side curtain airbag will protect the driver in case of a roll-over accident. Together with the steering wheel airbag, the overall driver safety is on point.
- Handling and manoeuvrability. Scania vehicles have an undisputable reputation for world-class handling and manoeuvrability. With our new range, this has been improved even further. The new steering design and robust heavy-duty cab suspension provide a smoother and more responsive handling and steering than ever

The performance modes are part of Scania Opticruise. They allow you to adapt the vehicle's performance to match certain operational demands. Switching mode is easily done while driving and the chosen mode is visible on the central display. If required, all settings can be altered or fine-tuned by a Scania service workshop. There are four performance modes in total:

- Standard mode. Provides optimal balance between fuel economy and hill performance.
- Economy mode. Tuned to minimise fuel consumption and thus contribute to lower fuel costs.
- Power mode. Prioritises engine response and uphill performance in order to optimise transport time.
- Off-road mode. Enables better traction control when driving in rough terrain and on surfaces with high rolling resistance.

The Scania Retarder interacts with the cruise control, exhaust brake, and wheel brakes to provide total downhill speed control. In addition, the retarder is available in two performance steps for different driving conditions. The more powerful R4100 is also available in a version with a clutch that disengages the retarder from the gearbox when it is not in use. This minimises the retarder's drag losses and saves fuel. 



## UD Trucks Check & Drive

**U**D Trucks Malaysia recently gathered its sales and marketing team from all over the country for a “Check and Drive” event. The aim of the event was to better familiarise the team with the top UD Truck models namely the new Quester (manual and automated manual transmissions), the Croner and the Kuzer.

Besides learning the ins and outs of the trucks, they also drove all four trucks around the Metro Driving Academy track in Puchong. UD Trucks Hub Malaysia & Oceania Managing Director, Steve Hedouin, said the best way to sell the trucks is when the sales and marketing team members have experienced the trucks for themselves. “Our customers are not strangers to trucks. They know what they want and need in a truck, and when they start asking all sorts of questions, our sales people need to be prepared to answer them and not just based on memorising facts,” he told Asian Trucker.

Also present at the event was Tan Chong Industrial Equipment Sdn Bhd Chief Operating Officer, Jaclyn Loy Swee Im. “To ensure everybody benefits from this programme, yesterday (April 22) we had a session for the Peninsular Malaysia team and today (April 23) for those from East Malaysia and the TCIE headquarters,” she said. To spice up the event, there was also a fuel efficiency contest using the telematics features in the trucks. “Customers these days are very keen on the telematics services as tracking fuel consumption and driver behaviour helps to increase uptime and maximising profitability,” Hedouin said.



*Asian Trucker writer Farezza Hanum Rashid test-drove four UD trucks and discovered how easy they all were to operate.*





The second truck was the Croner with Allison 3000, an auto transmission heavy duty. The cab is a 2.3-metre sleeper, and the engine is 8-litre and has 250 horsepower. Driving the Croner was relatively easy due to its auto transmission however because of its size, I was cautious with the accelerator at first. It did not take long at all, though, to get the hang of it and with the instructor's guidance, I managed to navigate the truck around the track. Unlike manual and AMTs, the Allison gearboxes have no power interruptions during shift changes.

The Croner's cabin features a modern, more open and ergonomic design, which means more comfort, less fatigue and higher productivity for the driver. Ergonomically designed seats with a wide range of adjustment, plus a steering column with adjustable length and angle, to suit a wide range of drivers and give the best driving position. Optional air suspension driver's seat delivers even better comfort. There is also an easy-to-read instrument cluster, backed up by the digital multi-function display (MFD). Croner is one of the few medium-duty trucks to have this as a standard feature in all models. A sleeper cab configuration is also available, with a single bunk bed for long-haul operations.

The Croner's new 5-liter and 8-liter engines, powered by UD Trucks' advanced technology, combine reliability with top class performance. Delivering high torque from low-rev with flat torque curves, these modern engines provide better pulling power, easier driving, improved fuel efficiency, extended maintenance intervals and longer engine life. Engine PTO (Power Take-Off) option with flange connector is available for both the GH5E and GH8E engines.

All Croner models come with a choice of manual and automatic transmissions. The manual 6-speed transmissions can cope with the toughest demands in various operation conditions, while the automatic transmissions are optimised for on-road logistics and garbage compactors. The Croner multi-leaf spring rear suspension has two stiffness options: Normal for

A few selected members of the media were also invited to test drive the trucks. First up was the UD Kuzer. This six-speed truck, although a manual one, was quite easy for this 156cm writer to navigate and as it is from the light duty segment, making turns was no trouble either especially if you are used to driving bigger cars. Changing gears is also easy for those who are intimidated by manual transmissions, because you do not need to balance the clutch and the accelerator like you do with cars.

Suitable for tight city traffic, Kuzer can manoeuvre in tough and narrow roads with its short turning radius. A polyurethane soft-touch steering wheel facilitates a more comfortable grip, and an ergonomically designed gear lever takes the strain off regular shifting. The steering wheel is also tiltable and telescopic, meaning less muscle use during awkward manoeuvring. At 2.1 meters, the Kuzer cab offers extra space and comfort, reducing fatigue on long days behind the wheel. With the largest cab in its class, Kuzer provides a more comfortable and safer driver environment.

With international laws demanding tighter controls on freight transport, and city authorities looking at ways of cutting diesel emissions, the Kuzer is equipped with an engine of 150hp and an optimised driveline and fuel coaching technology that provides better fuel efficiency, as well as an aerodynamically designed cab which facilitates lower fuel consumption. The 3.8L engine features a world class 3.0 Engine Management System which delivers lower RPM than a normal two-valve engine, enabling better engine torque and fuel savings. The engine's high power and torque guarantees power and control in road conditions.



standard loads and stiff for heavier cargo. Air suspension is also available as an additional option with mechanical height control valve and dump switch. The improved stability and cushioning is perfect for sensitive cargo freight.

The third truck was my personal favourite, the 12-speed manual transmission Quester GKE. It allowed me to have fun shifting the gears without the hassle of stepping on the clutch. Driving this heavy duty was actually very easy as the Quester display gives real-time tips on how to operate the engine. The Fuel Coach display shows the driver when to shift, brake or accelerate. The system is simple to understand and easy to use. The final truck was the Quester GKE ESCOT and a trailer attached to it, which was the main challenge of the test drive. During the first round, I relied heavily on the instructor's instruction on when to make turns while on the following two rounds, although I felt more comfortable with the trailer, I was still a little apprehensive.

New Quester's flexibility makes it suitable across a variety of applications. An optimised powertrain, fuel coaching system and aerodynamic design plus a spacious comfortable sleeper cab makes it ideal for long haul. The New Quester is also especially adapted for the construction and mining industries. It is strong, reliable and designed for handling high payloads. For waste management, the Croner with Allison 3000 (automatic transmission) means easier driving with simple stop-start in tight urban environments with many collection points. When combined with a powerful driveline, lighter tare weight offers the possibility to transport more general cargo on longer distances.

the new Quester cab is an impressively spacious and walk-through cab equipped with a bed for long distance assignments. With the introduction of cab air suspension, cab vibration is greatly reduced. This helps lessen driver fatigue







and enables better productivity. A smoother ride is also much kinder to the goods being transported. New Quester features a new air suspended seat with lumbar support and optional armrest for improved driver comfort. ESCOT, the latest evolution in 12-speed automated manual transmission, and an interior designed for driver comfort, provide a sophisticated and comfortable driving experience that reduces driver stress and fatigue. With ESCOT always selecting the optimal gear, drivers can improve efficiency and productivity regardless of their skill level or experience.

The 8-liter and 11-liter engines are powered by UD Trucks' advanced technology and combine reliability with top class performance. Delivering high torque from low revs with flat torque curves. New Quester models come with a choice of 9-speed and 12-speed manual transmission, that can cope with the demands in various operation conditions. With key components made of aluminium, ESCOT automated manual transmission contributes to New Quester's low weight for higher payload. By choosing the right gear, ESCOT delivers efficient, productive driving with high average speeds and low operating costs. The PWR+ mode on ESCOT makes construction assignments productive with increased power and high running performance in tough conditions. It features a rock loose mode for quick escape when stuck in slippery and muddy conditions.

For each truck, we drove three rounds around the track to ensure that we really got the feel of the truck where the first rounds were for us to get used to the trucks while the second and last rounds were for the telematics systems to monitor our driving behaviours and fuel consumption. **F**



# Tatt Seng Jaya Automobile

*From a small workshop to what it is now, Tatt Seng Jaya talks to Asian Trucker on the secret to success.*

**T**att Seng Jaya was registered as a sole proprietor business on 21 November 1980 by Mr Khor Kong Siah. During the initial stage, the company occupied a small workshop, measuring approximately 150 square feet, located at Simpang Empat, Bukit Tengah. The business was then operated by Mr Khor himself and a worker. The services provided then were limited to only panel-beating (knocking), welding and spray painting of small sized vehicles like motorcars.

In 1983, Tatt Seng expanded to a bigger workshop with built-up area of approximately 1 000 square feet in Bukit Tengah. The workforce of the business was increased to seven persons, four in knocking and welding section and three in spray-painting section.

The number of customers continued to increase and the workshop again reached its maximum capacity in 1985 and had to relocate to Bukit Mertajam with a land area measuring approximately 8 000 square feet. With a more spacious and well-distributed workshop, Khor embarked on a major expansion and a range of new services were introduced. Tatt Seng Jaya not only concentrated on knocking, welding and spray-painting services but also provided mechanical servicing of vehicles. The services provided also extended to heavy commercial vehicles, which included trucks, buses and vans.





In 1997, with the expanding customer base and plans to further upgrade the quality of its services through application of more advanced technology in performing their jobs, the bigger workshop soon reached its maximum capacity once more.

Thus, Khor embarked on his next expansion phase by acquiring an acre of industrial land at Bukit Minyak Industrial Park in the district of Seberang Perai Tengah, Penang. This land is strategically located with easy access to North-South Expressway.

Today, Tatt Seng has constructed a double storey factory building on the land acquired. The new built-up area covers approximately 7 000 square feet, complete with an administration office and workshop block. With an excess landbank, Tatt Seng is able to increase its operating capacity as and when required.

Managing a successful business is no walk in the park, especially so in the automotive claims industry whereby word of mouth lend credibility to a business. "Workshops are everywhere. In order to distinguish oneself from others, one has to stand out. To me, it meant that I had to go above and beyond to provide good quality service and parts to my customers. To top it off, an additional day a commercial vehicle is sitting on my workshop, the more losses it will incur to the operator. Therefore, it is always a fight against time" shared Khor.

On how he manages to provide excellent quality in a short amount of time, Mr Khor said that it is all thanks to his "business partners" at YonMing. "Ever since I started engaging the services of YonMing, I could never go back. They constantly manage to deliver items on time. This criterion is essential to me as customers will never return if they have had an unpleasant experience. Usually,

when I am in need of a certain spare part, I will give the guys at YonMing a call. If they have the certain item in stock, they will deliver it as soon as possible. If the particular item is not in stock, they will help me source it within the shortest time possible. And I am thankful that they have not left me disappointed after all these years."

When asked if he would source his parts elsewhere, Khor said "no. I am satisfied with the current way things work between YonMing and I. I know they are slightly more expensive but quality is something I place extreme importance in. I am confident that the parts supplied by YonMing are genuine and I like that they can source parts for me with a very short lead time. If I were to source my parts from elsewhere, I am afraid that it would lead to compromised quality. That is something I want to avoid altogether. For a slightly higher price and a peace of mind, I will continue to work with YonMing for as long as I can." **T**







## MAN Keeps Melaka's Trucks Mobile

There is no indication that it is a Sunday as the noodle shop opposite the Ornapaper Berhad's premises is packed even at 10am. Located in Batu Berendam, this is one site where the MAN Mobile service van is a regular visitor to service the trucks of the company. The White Curry Noodle shop is also a regular meeting point of the three business leaders who, according to one of the group, meet every single day to discuss the jobs at hand. Making the arrangements was Gopinathan Chellayah, who managing all the special offsite servicing requests from customers and leads the Rawang workshop.

Sai Han Siong, Managing Director of Ornapaper has an interesting background as he started out with a quarry as his main business (Mega Quarry Products Sdn Bhd). Having been in this line for over 20 years, the paper business is his latest addition. In his quarries, he operates 11 trucks, which are mainly coupled with tipper trailers. While there are no MAN trucks in operation in the quarry at the moment, Sai has made the decision to use the German brand in the very near future. Being happy with the performance of MAN trucks deployed for the paper business, he is confident that the MANs will also contribute to the success of the quarry.

The delivery of paper is an interesting one as it is also a time sensitive business. "Nowadays, paper is delivered in a JIT (Just in Time) manner. His drop of points are in Johor Baru, Melaka and Ipoh. "One of my trucks is a MAN and we have made good experiences." One of the major changes he is planning to make is to hand over the maintenance and service of the MAN trucks to MAN. In the past, these works have been carried out in the in-house workshop. "We realise that this kind of job is better left with the experts. This way we can concentrate on our core business. When the new trucks arrive, we don't want to have the hassle to deal with in-house issues." What he expects is that that any breakdown will be fixed faster. "We are happy to hand over the headache to others." His decision to purchase MAN trucks was motivated by the recommendations of the others in his daily meet-up group. "These MAN trucks are said to be tough!"

*The concept of MAN's mobile service truck continues to be a hit with transporters. Melaka's trucker depend on the flexible service option that the German brand offers. We went to find out more.*

MAN also posts new opening times for some of their workshops:

- Johor Baru & Prai 8:30am till 5:30am 5days & 8:30am till 1:00pm on Saturday (by Appointment)
- Port Klang 8:30am till 5:30pm 6days a week
- Rawang 8:30am till 5:30pm 7days a week (Sat and Sun) only by appointment for service and minor jobs.

Moving all sorts of building materials, Ko Chuan Way of Sim Aik Chan Sdn Bhd, operates a fleet of mixed brands and sizes of trucks. Of his fleet, four prime movers are from MAN. Huang has a surprising answer when asked





Operating across Peninsular Malaysia, Huang is happy to be able to depend on the mobile service and breakdown service. While he has a panel workshop to handle certain issue, servicing is done by the dedicated staff of the MAN mobile service van. "Bookings can be done as early as a day before the actual service and this helps us keeping the trucks being profitable," he said. With the burden of maintaining the trucks in tip-top condition handed to MAN Trucks, Huang can concentrate on his business expansion and he is currently finalising an order for five more MAN trucks to support his ambitions.

"The MAN mobile service is a very good idea," chimed in Huang Chong Huat, Managing Director of Sky Mix Sdn Bhd, who joined the illustrious breakfast club. His fleet of 40 trucks has a population of 12 MAN and he is also planning to add more. "Yes, for sure in-house mechanics can get the job done, but the MAN staff will certainly be more professional and faster in fixing the MAN truck as they are more familiar with the vehicle." He also said that there are some issues that a mechanic that is not specifically trained on any brand may not be able to identify and solve a problem. According to him, this is the advantage when it comes to using the dedicated service of MAN: problems are solved faster and the trucks are back on the road to generate revenue faster. Sky Mix started out with used trucks but soon the management realised that breakdowns can be very costly. "That is why we now opt for new trucks from MAN. Now that we get new trucks, they come with warranty, which means that this is hassle free."



L to R: Thayalan Subramaniam (MAN), Ko Chuan way (Sim Aik Chan), Sai Han Siong (Ornapaper), Gopinathan Chellayah (MAN), Kee Keng Chai and Huang Chong Huat (Sky Mix) and Fadhil bin Jamaluddin (MAN).

Although it is a Sunday, the wheels never stop turning and the MAN mechanic on duty takes to fixing the trucks so that they can be back on the roads in no time. Mr Thayalan Subramaniam, who heads the service team of MAN Truck and Bus Malaysia was certainly proud to announce that Fadhil bin Jamaluddin, the service technician on duty that day was the longest serving employee of MAN in Malaysia. Surely, he will have any issue sorted out in no time. **F**

why he opted for MAN. He explained that "We bought them because of the Kuantan issues in the news. While certain things were highlighted as not being done right, one thing we could see is that the trucks needed had to be strong. And MAN trucks are strong." MAN trucks pull tipper trailers and one of the regular stops he is making is the quarry of Sai Han Siong. Although the trucks can take a heavy load, one issue he laments is that enforcement agencies can sometimes be very "unfair" to transporters. "What are we going to do about our load getting wet in rain..."





## Daihatsu Malaysia's Commitment to Provide the Best for Customers

**D**aihatsu is recognised globally as one of the oldest Japanese automakers in the world and since then have made their mark in Malaysia for almost 40 years in the making since 1980. Daihatsu Malaysia, with a long history in distributing light commercial vehicles also has an aftersales service that could match even the big boys of commercial industries. Daihatsu (Malaysia) Sdn Bhd Head of Aftersales Division, Haidzir Sarih walked Asian Trucker through the services provided.

"Currently we have 25 sales showrooms, 37 aftersales service centres, two body and paint workshops and 35 spare part dealers nationwide. Among the 37 service centres, 26 are dealers' workshops," Haidzir said. All Daihatsu authorised service centres are well established with sufficient hoist and service bays, dedicated tyre alignment stations and wheel balancing machines to range of latest technological diagnostic tools. Daihatsu service centres can accommodate service maintenance jobs not only for light commercial vehicles but also has the expertise in handling medium to heavy duty segment such as Hino prime movers and buses.

"We ensure that our technicians and service teams are highly experienced and trained, making sure they are at the very top of their games to serve our customers. Quality of service is measured through the performance of every pick-up and van that is carefully inspected by Daihatsu technicians," he said, adding that continuous trainings are done in-house by our local product specialist as well as from Daihatsu Motor Co., Ltd., (DMC) Japan. "Recapping back to last year when we launched the very 1st auto transmission panel van in Malaysia, we've invited speaker from DMC whom is also the Technical Expert to conduct an extensive product technical training specifically to all of our service team," Haidzir said.

*From spare parts to mobile service and the Kaizen practice, Daihatsu's after sales team does it all.*

Every new Daihatsu Gran Max comes with a standard three years or 100 000km (whichever comes first) manufacturer's warranty coverage. Additionally, Daihatsu also carries complete line of genuine parts, each designed and manufactured that meet Daihatsu's high-quality standards. All Daihatsu genuine parts comes with three months or 20 000km (whichever comes first) warranty coverage. One of the factors that causes vehicle downtime is the unavailability of parts replacements. Here at Daihatsu, there is a guaranteed of parts availability through a systematic parts inventory management with the Daihatsu manufacturer - perks for being the sole distributor of Daihatsu genuine parts.

After Sales Support Manager, Yus Nur Rezwani Jumairy, said they also offer locally manufactured parts known





as OEM parts which are of “reasonably priced, competent quality and with warranty coverage as another option for customers that are looking for second alternatives. Of course, these selected OEM parts has to meet our quality standard before recommending it to our customers to avoid jeopardising the vehicles.”

For further convenience, Daihatsu customers can take advantage of the Daihatsu Mobile Service. The team provides a hassle-free and practical experience by servicing any Daihatsu vehicles at customers’ convenient place and time, by telephone appointment. The Daihatsu Mobile Service team is dedicated to bringing its service which includes engine diagnosis, brake fluid flush, replacement of normal items i.e. timing belt, brake pad, wiper, battery, absorber and etc to customers’ doorstep without any additional charges.

Haidzir shared “The Daihatsu Mobile Service was introduced to Ipoh after the integration of our showroom (1S) and service centre (2S) outlet to a full fledged 3S centre at Jalan Kuala Kangsar Q3 last year. Our mobile service is very well received by our fleet customers in Klang Valley, Johor Bahru and Ipoh.

Being a Japanese establishment, Daihatsu is also looking into KAIZEN best practices as a way for continuous improvement particularly in strengthening service retention with all of Daihatsu owners. Service representatives will be reaching out to inactive customers through various courtesy visits to personally learn why customers have not been frequenting Daihatsu service centre for over two years. “There are mainly three reasons for this namely the distance of customers’ office to our facilities; the waiting time; and the price of our spare parts. And from thereon we educate our customers on other services we provide to address their concerns. To counter first concern, this is where our Daihatsu Mobile Service team come into

effect most by bringing our service to customers’ doorstep at their convenient place and time. Normal service maintenance schedule will take approximately two hours or more depending on the condition of a vehicle, with our Express Maintenance Bay (EMB) which made available at all of our branches averagely takes within an hour. This is popular among our customers; thus, we advise them to make earlier bookings. Genuine parts are known to be slightly on the higher side for its authenticity, quality and performance assurance in the long run. We’d often advice our customers to go with genuine parts, however in any circumstances where budget doesn’t allow for certain customers, we’d offer our selected local OEM spare parts which are slightly cheaper.” Haidzir said.

The Kaizen approach has seen some successes where there’s encouraging growth in successful conversion of inactive customers to our service centres. “We are happy with the figure we have now but of course, we want to convert them 100 percent,” Haidzir added. This approach was carried out starting March last year in Johor Bahru and October in Ipoh. Starting June 2019, it will be carried out in our flagship 3S Shah Alam outlet as well as for our 3S Kota Kinabalu outlet. Also, this year, Daihatsu is planning to extend its spare parts inventory specifically to corporate fleet customers. “Fleet owners usually only buy vehicles from us but for servicing, some of them have their own workshops and they would buy cheaper imitation parts instead. Therefore, we want to ensure that they use the best parts for their Daihatsu vehicles by offering them special packages,” Haidzir concluded. **F**



**T**ee Sing Sam still remembers the early days vividly. He had to drive his small truck all over Johor, Melaka and Negeri Sembilan to collect freshly harvested palm oil fruit bunches from smallholders.

It was back-breaking work loading the heavy fruit bunches as each one could weigh up to 30 kg. Tired from all the travelling and loading, he would often end up sleeping in his lorry by the roadside in the middle of nowhere.

These days, the genial 75-year old can afford to rest and focus on his passion for charity work. Since handing over the reins of his small palm oil trading business to his son, Tee Tze Ming, he has watched Lam Mah Trading Sdn Bhd grow into one of the largest transport companies in Bukit Gambir, Johor. From just six small trucks, Lam Mah now has a fleet of 24 trailers servicing palm oil plantations all over the Southern region.

Tze Ming has also managed to tap into another thriving business -- supplying dried palm fruit kernel to factories around Johor to be converted into biomass energy.

The lean and fit 40-year old, who joined his father after completing Form Five in 1998, has managed to grow Lam Mah Trading exponentially through a combination of strong business acumen, discipline and the willingness to adopt new technology, products and services.

"The palm oil trading was getting too competitive and I decided to change our focus to investment and transportation in 2008. We have not looked back since," he said.

From the spick and span condition of the Lam Mah Trading workshop and truck depot at Jalan Sengkang, it is clear that he is also a firm believer in cleanliness and orderliness.

He is also obsessed with road safety. He took time off to personally participate in a safety driving course so that he could pass on the knowledge to his drivers. He has also proactively produced and placed warning stickers on the left side of his trucks to warn motorcyclists of the dangers of being in the blind-spot.

## Father's Work Ethics and Son's Vision Ensure Lam Mah's Success



To keep its fleet of trailers in tip-top condition and plying the roads, Lam Mah Trading has relied on the support and recommendations of Muar-based Bukit Pasir Shell Filling Station Sdn Bhd.

"We have entrusted all our lubricant and fuel needs to Shell and the benefits have been very clear. The switch to Shell Rimula has enabled our trailers' oil change interval to be extended to 20 000 km from a mere 5 000 km before. As a result, we enjoy significant savings and lower total costs of ownership from reduced downtime; lower repair and maintenance costs; and longer engine life. More importantly, this has enabled us to strengthen Lam Mah's reputation for unbeatable service and excellent quality," he said.

The elder Tee is obviously extremely proud of his son. "We work well together and he is a filial son. He had the vision to venture into transportation and biomass supply, which are now much bigger revenue earners compared to oil palm trading. Lam Mah Trading is in good hands and with the support from Shell, we can go far," he said. **F**





## That's not what You should Do as a Specialist

**W**hen I am doing interviews, I often ask: "What is it that your company does?". What I am looking for is a unique description of what the business is all about. For example, if you ask Disney, they don't tell you that they make movies or operate theme parks. No, they aim to entertain. In our field, I often get a variation of "To be the leading integrated transport company...". Which means that the company that is behind this should be really good in providing transport solutions.

To provide this type of service, companies we feature have a fleet of trucks. Some have few, others a great number; such fleets might be a mix of brands and sizes or just the same vehicle times 15. And while these trucks are absolutely crucial, such companies usually also handle a lot of other things. For instance, they have a workshop to ensure that the truck fleet is always maintained and repairs can be done quickly.

However, repairing trucks is a skill that is different from those needed for the actual transportation of goods. Would it not be better to have a specialist handle the upkeep of the vehicles? Many of us can relate to football. The job of the players is to score goals (or to prevent the other team from scoring), not to be responsible for their equipment. Unfortunately, I only know the German term for the guy that does that: Zeugmeister. This person is actually responsible for the shoes and other equipment of the players. He ensures that laces are in good condition, the shoes are clean and greased. He is an expert on how to keep shoes in perfect working condition. So that the players can concentrate on what they are being paid (a lot) for: scoring goals.

The same can be said about tyres. Whenever we discuss tyre management with tyre makers, we realise that in theory this is simple. But in reality, there is a lot more to tyre management than just ensuring the right pressure once a week. It is almost like a science. And when you think of the tyres as being the one consumable

that contributes the second highest amount of cost, then one realises that this is truly an important aspect when looking at the bottom line. One of the issues that concerns tyre management is documentation: just checking tyre pressure randomly doesn't do much and one needs to be more organised around this. Tyre management itself has become such a specialised and complex field that transporters may no longer consider this as part of their jobs. Maybe here too, it is time to divest this activity and get professional help to manage this aspect if you want to be a transportation specialist and not a tyre expert.

Lubrication has also become a very complex area of running a fleet. Each moving part of a truck may require very specific lubrication and using the right brand and specification may make a big difference to performance. The current practise seems to be that lubricants are purchased based on price, rather than on quality. Given that among the engine oils one needs for a fleet that is constantly running, this may seem like a good idea *prima facie*. The wrong specifications of lubricants however, may result in loss of performance, increased wear and tear and higher fuel consumption. Most of the providers of lubricants I have spoken to are happy to offer consultative services to fleet owners in order to improve the performance of the vehicles by means of sharing their knowledge on lubrication.

Perhaps it is time that we employ more specialists in transport operations. People that really know their trade, which may be part of keeping a fleet running, but is not the core business. After all, transporters don't get involved in construction of roads. Experts in their field build them so transporters can focus on their job of transporting goods. 



## Hap Seng Commercial Vehicle 3S Centre Opening at Kuantan

"Hap Seng Trucks Distribution provides commercial vehicles that are reliable with economic efficiency, as well as first-class products and service qualities. Today we are proud to unveil the opening of a new 3S centre in the East Coast of Malaysia together with our authorized dealer Hap Seng Commercial Vehicle. This dedicated 3S facility will further strengthen our position as we continue to expand our presence in Malaysia. Through our valued dealer partnership, we are very pleased to launch the new 3S commercial vehicle centre that will provide the highest quality of after-sales services to live up to the tagline, 'Trucks you can trust' ," said its Chief Executive, Roland Schneider.

"Hap Seng Trucks Distribution has been a strong contributor to the development of the nation's automotive sector. The launch of the Hap Seng Commercial Vehicle 3S Centre at Kuantan comes as another positive investment with the potential to benefit the East Coast Economic Region's (ECER) goal of spearheading the region's socio-economic development," a guest commented.

"Our passion for excellence has been a major driving force behind the success of the Mercedes-Benz and FUSO commercial vehicle brands. We are very happy to bring the brands' confidence and reliability to our customers in the East Coast. We understand the needs of our commercial vehicle customers whose businesses rely heavily on their vehicles. The Hap Seng Commercial Vehicle 3S Centre (Kuantan) is a testament to our dedication to bring unparalleled offerings and services closer to our customers," said Chief Operating Officer of Hap Seng Commercial Vehicle, Mr Wong Leh Seng.

The Hap Seng Trucks Distribution authorized commercial vehicle dealer, Hap Seng Commercial Vehicles 3S Centre (Kuantan) is located at No. 21 Jalan Industri Semambu 1, Kawasan Perindustrian Semambu, 25300 Kuantan, Pahang. 

**H**ap Seng Trucks Distribution (HSTD) together with its authorized dealer, Hap Seng Commercial Vehicle (HSCV), celebrated the official opening of a 3S Centre in the East Coast region. The opening of HSCV 3S Centre which took place on 26 April in Kuantan, is a testament of HSTD's confidence in the long-term business potential in the East Coast Economic Region.

Strategically located in Kuantan, HSCV 3S Centre (Kuantan) has the capability to facilitate sales, service, maintenance and repairs for both Mercedes-Benz and FUSO commercial vehicles.





almost certain that shipment and storage of goods will shift to Malaysia. Malaysia will become the automatic choice for many customers looking for a regional distribution hub in the Asian region. As such, I think The 12 Waves will be able to cater to all the storage needs," said Dato Micheal Tio, Group Chief Executive and Managing Director of PKT Logistics Group Sdn Bhd.



Late last year, IKEA decided to make Malaysia its regional distribution centre while Daiso Japan has decided for Malaysia to be home to its global distribution centre. These moves by multi-national companies display the increased demand and activity in the Malaysian logistics industry. The warehouse from PKT added capacity at a very suitable timing. The 12 Waves will be able to fulfil the demand of customers with a substantial storage capacity along with state-of-the-art facilities to ensure goods are kept in a safe and secure environment.

Tio added that "In order to cope with the increased capacity of the 12 Waves, PKT Logistics purchased 20 Foton Daimler trucks from Mpire Commercial to be able to cater to the needs of its customers. We currently have about 30 Smart Truckers and we will be transferring some of our Smart Truckers, depending on their preference, to the 12 Waves to ensure operations run smoothly. The Smart Truckers programme at PKT allows truck drivers to become skilled professionals in their field. It is a four year programme that enables graduates to earn a decent salary while driving trucks. The main objective of this programme is to transform the whole transport industry and cultivate professional truck drivers." **T**

# The 12 Waves

***Built at a cost of RM120 million, the 650 000 square feet warehouse brings state-of-the-art features such as solar panels, natural lighting and ventilation as well as an advanced security and surveillance system.***

**L**ocated in the fast-growing Batu Kawan Industrial Area, The 12 Waves is the central component in PKT's integrated One Auto Hub development which will also contain components such as The Ship Campus, The Automotive Boulevard, The Lighthouse Lodge and The Andaman Wharf. The 12 Waves was also given recognition by the Malaysian Book of Records as The Longest Warehouse in Malaysia and The Biggest Single Storey Warehouse in Malaysia.

"Malaysia is expected to become the next logistics hub. Singapore handles about 30 million TEUs of shipment, while Malaysia with its two major ports, Port Klang and Port of Tanjung Pelepas handles about 12 million and eight million TEUs of container shipment respectively. With a combined capacity of 20 million TEUs, Malaysia is second in the ASEAN region after our neighbouring country, Singapore. With the increased cost of living and labour costs, it is





# Lighter and Harder is Better for Your Trailer

*Italian OEM Mantella introduces groundbreaking tipper trailer, guaranteeing maximum payload, fuel efficiency and extreme durability.*

**M**antella revolutionized the design of its innovative Stratosphere tipper trailer by implementing major design advances in the use of high-strength steel. The company has taken full advantage of the latest high-tech materials developed and produced by the Nordic steel manufacturer SSAB: Hardox 500 Tuf and Strenx 960.

## **510 kg More Payload**

The combined weight reduction of using abrasion-resistant Hardox 500 Tuf in the body and Strenx 960 in the chassis is 510 kg (1124 lbs.) compared to the previous design, which translates to an increased payload of 510 kg (1124 lbs.) on every trip. And higher load capacity is what practically every customer is looking for. The new design won the international Swedish Steel Prize 2018. Reduced weight improves sustainability.

Mantella S.r.l. is a family business located in Lamezia Terme in the Catanzaro province of southern Italy. The company has set ambitious goals to design stronger and lighter semitrailers that will carry larger payloads while saving fuel and reducing CO2 emissions at the same time.

Reducing emissions is important since road transport accounts for 17.5 percent of overall gas emissions in Europe. By 2050, these emissions will need to be at least 60 percent lower than in 1990 and be firmly on the road towards zero.

“By lowering fuel consumption and CO2 emissions per ton kilometer we are contributing to a more sustainable world. To successfully develop this lightweight trailer, the entire company has been involved – design

engineers, production, management and purchasers. The Stratosphere trailers make use of all the benefits obtainable from SSAB’s high-strength steel grades Hardox 500 Tuf and Strenx 960. Naturally we are also in the process of implementing stronger and lighter design solutions for our other trailer series,” says Gregorio Mantella, Plant Director at Mantella S.r.l.

## **Hardox 500 Tuf Saves 365 kg of Body Weight**

Stratosphere trailers from Mantella have tipper bodies made of Hardox 500 Tuf wear plate. This new Hardox grade delivers longer wear life while having the same toughness as the previously used Hardox 450 grade.

Thanks to the higher wear resistance of Hardox 500 Tuf, Mantella could reduce plate thickness by 1 mm (0.039”). This saves on average 365 kg (805 lbs.) of body weight.



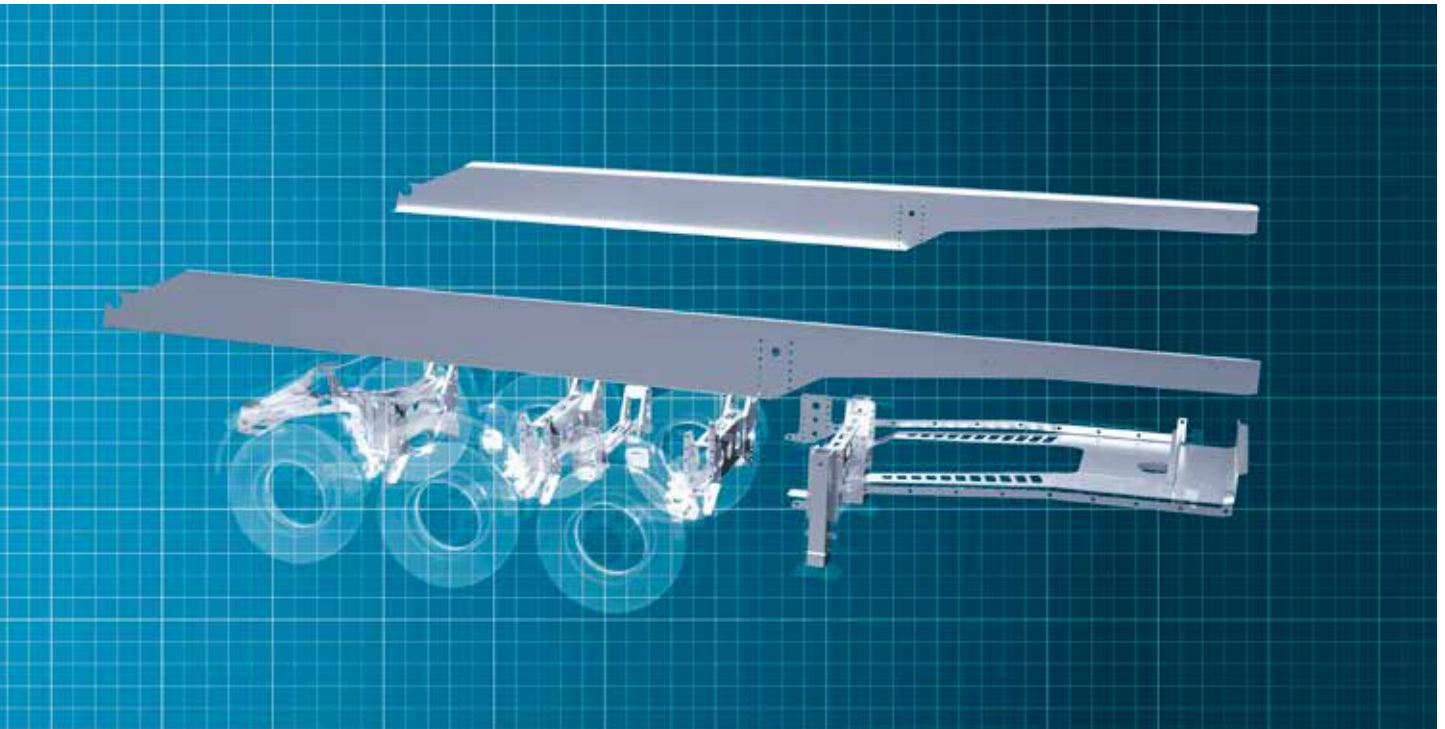

Reducing the thickness is possible thanks to the increased hardness in combination with the high toughness and dent resistance that comes with Hardox 500 Tuf. Even after many years of use, the steel will be thick enough as not to compromise the integrity of the body.

Hardox 500 Tuf combines the best properties from the Hardox 450 and Hardox 500 wear steel grades. It has an unusually narrow hardness window of 475-505 HBW. The relative wear life for Hardox 500 Tuf can be 30-50% longer compared with Hardox 450. The high toughness gives excellent resistance against dents and cracks when the steel is hit by sharp and heavy objects. Hardox 500 Tuf has a guaranteed impact toughness of 27 J at -20°C (20 ft-lb at 4°F) and, for 20 mm (0.79") plate, a typical value of 45 J at -40°C (20ft-lb at at 4°F).

### **Body Designed for Stiffness**

When using a thinner material, the trailer tipper body has to be designed in a way that ensures the stiffness and overall stability of the body. When raising a fully loaded body with a front mounted hydraulic cylinder, the body experiences high stresses. If it's not designed correctly it could result in a sudden buckling of the sides.

To counteract this, Mantella incorporated a number of design changes such as adding horizontal bends to the side panels. This gives the necessary stiffness to the entire body. The hydraulic cylinder attachment, top rails, rear frame and tipping pivots have also been redesigned for added torsional stiffness.

### **Redesigning with Strenx 960 for Productivity and Performance**

Mantella challenged the conventions when the company decided to produce the longitudinal beams of the chassis by advanced bending of a single flat strip of Strenx 960. Instead of making a traditional I-beam by welding flanges and web together, Mantella used press bending to produce a Z-shaped form without welding.

Tipper trailers typically operate off-road under extremely demanding conditions. They are subjected to a variety of severe load cases that are difficult to predict. Fatigue usually sets the design limits. Mantella has invested a great deal of development work in weld technology and the placement of welds to optimize fatigue strength. By eliminating the welded I-beams and

by leaving the flanges untouched by welds, fatigue strength of the chassis is greatly increased.

### **Light as Aluminum, with the Benefits of Steel**

The new trailer chassis in the Stratosphere series weighs in on par with aluminium, and has all the durability, fatigue strength and production advantages of steel. The Z-beams take about 50% less time to produce compared to welded I-beams. In addition, lateral stiffness is increased by 10 percent and torsional stiffness by 12 percent.

By upgrading to Strenx 960 steel, Mantella not only offers its customers a chassis that is 145 kg (320 lbs.) lighter. It also has superior mechanical properties and improved road handling.

### **Resulting savings**

- A Stratosphere trailer has a 365 kg (803 lbs.) lighter body and a 145 kg (320 lbs.) lighter chassis, allowing for an extra 510 kg (1124 lbs.) of payload for every trip
- It can save 12 000 liters (3170 gallons) of fuel and 30 tons (60.000 lbs.) of CO<sub>2</sub> during 12 years of service 2
- The vehicle can earn EUR 0.07 extra for every km, or EUR 8 400 per year, and pay for itself in 4-5 years 



Lee Hon Siang has been applying the Valeo liquid coolants in all 14 of his trucks for two years now and has saved more money than before using the coolants. The 34-year-old Managing Director of B&B Transport Sdn Bhd in Melaka said with the coolants, there are no longer engine damage due to overheating. "The water doesn't overheat, making the engines and water tanks last longer," he told Asian Trucker at his office, recently. "Maintenance is low as the trucks do not break down on the road anymore, and there's no leakage," he added. Prior to using the Valeo coolants, Lee said he used water for his trucks and there were always leakages. "Using Valeo is a great step for saving, plus the trucks are also moving much smoother," he said.

Lee started using the Valeo coolants after YonMing recommended the product to him. B&B Transport has been a YonMing customer for over 20 years, when Lee's father was still running the 38-year-old company, where Lee has been working since he was 14 years old. B&B Transport started as a small family business with two low loaders to provide services to various clients in the cabin and machinery industry nationwide.

"My drivers' feedback after using the coolant was that they save more time as they do not need to keep adding water and that the engine stays cool. I have been recommending the Valeo coolants to my friends be it for their personal or business vehicles because 80 percent of the people in the market do not know that they need to use coolant. They want to save money by using water but that is more costly because there will be corrosion which will lead to a lot of other damages. The worst damage that could occur is to the engine and replacing engines could cost up to hundreds of thousands of ringgits," Lee said.



## B&B Transport Saves More with Valeo Coolants

*Valeo liquid coolants avoid leakages, corrosion and engine damage.*

Valeo originates from France while this particular coolant is produced in Italy. The Valeo liquid coolant is an engine coolant which is a heat transfer fluid. Its function is to maintain the engine at an ideal operating temperature. It is maintained under pressure and circulates between the engine and the radiator. It consists of water with an additive such as ethylene glycol or propylene glycol in order to raise the boiling point and increase its resistance to freezing. The high quality of Protectiv 50 components prevents:

- Corrosion: Electrochemical process in which a metal reacts with its environment to form an oxide or other compound.
- Scale deposits and cavitation phenomenon: Chemical reactions in your engine cooling circuit can engender scale deposits and thus cavitation, which will damage your waterpump.

The Valeo Protectiv 50, which is sold here in Malaysia, is ready-to-use liquid coolants and contains 50 percent of mono-ethylene glycol, in accordance with vehicle makers' norms such as DAIMLER DBL 7700.30, MAN 324-NF, Volkswagen 774 D/F & MTU MTL 50 48 based on Organic (G12) technology with 100 percent organic additives (corrosion inhibitors, anti-deposit, antifoam and others). It allows for a high thermal conductivity and thus protect the engine cooling loop from freezing and overheating with a temperature range protection depending on the concentration of mono-ethylene glycol. Valeo's Protectiv 50 temperature protection range is - 35°C to +108°C and is available in a five-litre bottle, 25 litre can and 1 000 litre tank. Malaysia, Valeo Protectiv 50 can be purchased from YonMing.

All these variants prevent corrosion (electrochemical process in which a metal reacts with its environment to form an oxide or other compound) and scale deposits and cavitation (chemical reactions in the engine cooling circuit which can engender scale deposits and thus cavitation, which damages the water pump.) The coolant should be replaced every two years as over time it loses its cooling, anti-corrosive and anti-freeze properties. **F**



# Shell Builds Cutting-Edge Storage Facility To Support Rising Demand For Its Fuels



In addition to the new 10 million-litre storage tank, the expansion plan also included a new loading bay with six loading arms configured to dispense three key Shell fuel products – Fuelsave 95, V-Power 97 and Fuelsave Euro 5 Diesel – at a rate of 1 800 litres a minute. This increases the efficiency of loading processes for road tankers. The tankers now can be fully loaded in just 25 minutes, which significantly reduces the congestion at the Klang Valley Distribution Terminal (KVDT).

The storage tank is constructed using the innovative jack-up method instead of the traditional bottom-up process. Here, the top section of the tank including the roof is constructed first before being lifted with hydraulics, which enables the lower sections to be assembled. This minimises the use of scaffoldings, the need for workers to work at height and enabled construction to proceed safely and get completed ahead of schedule, despite space restrictions and ongoing activities in the vicinity.

Shell Malaysia Trading Sdn Bhd has officially launched a new cutting-edge fuel storage tank and an additional loading bay at Westports, Port Klang, in April. This is to boost its capability to meet the growing demand for Shell fuels in the Central region of Peninsular Malaysia.

The new tank, the tenth such facility owned by Shell at the terminal, was constructed under Phase 4 of the Shell Westports Terminal Expansion Plan. It was officially launched by Datuk Iain Lo, Chairman of Shell Malaysia and Datuk Ruben Emir Gnanalingam, Group Managing Director of Westports Malaysia Sdn Bhd.

The successful completion of Phase 4 of the Shell Westports Terminal Expansion Plan was a strong testament to the close co-operation and high safety standards adopted by the teams from Shell Malaysia, Westports Malaysia Sdn Bhd, the project consultants and contractors. 

## BYD's Next Generation Battery Electric Yard Tractor combines performance, comfort, reliability

The BYD (Build Your Dreams) next generation 8Y battery electric yard tractor makes its world premiere at the Advanced Clean Transportation (ACT) Expo in Long Beach, showcasing a design that combines performance, reliability, improved driver comfort and operability, along with zero tailpipe emissions and quiet operation.

The unveiling coincided with the delivery of 14 second generation 8Y yard tractors to two BNSF Railway intermodal facilities in Southern California. First generation 8Y yard tractors have been in use at railyards and the port since early 2018.

BYD's second generation yard tractor features improvements that directly reflect feedback on the first generation. 

# Groundbreaking Ceremony for the First Overseas New Factory of Prinx Chengshan



**M**ore than 400,000 square meters of Prinx Chengshan overseas new factory will manufacture all-steel radial and semi-steel radial tires after completion, aiming to better meet the pleasant travel experience for users around the world.

On March 31, 2019, Prinx Chengshan held a groundbreaking ceremony for the new plant of Prinx Chengshan Thailand at Eastern Seaboard Industrial Zone

WHA EISE 3 (Chonburi), Thailand. This world-class new plant is expected to be commissioned in mid-2020. By then, it will further consolidate and expand Prinx Chengshan’s global production capacity, enhance its international competitiveness, enhance its product brand image and influence, and thus better meet the needs of overseas customers. Prinx Chengshan was founded in 1976 and successfully listed on the main board of the Hong Kong Stock Exchange in October 2018.

The plant will adopt the tire industry’s leading design philosophy and be designed with AI manufacturing standards. The initial stage of the plant is expected to invest nearly \$300 million for the construction of infrastructure and annual production line of 4 million semi-steel radial tires (PCR) and 800 000 all-steel radial tire (TBR). **T**

## Nexen Tire Announces the Grand Opening of ‘THE NEXEN univerCITY’, Nexen Central Research Institute



**N**exen Tire, a leading global tire manufacturer, announced that it held the grand opening ceremony of ‘THE NEXEN univerCITY’ that is expected to be the driving force for future growth on Tuesday April 30, 2019.

The grand opening ceremony was attended by more than 300 people, including Nexen Tire Chairman Kang Byeong Jung, Nexen Tire Global CEO Travis Kang, the Chairman of Korea Employers Federation Sohn Kyung Shik, the Chairman of Federation of Middle Market Enterprise of Korea Kang Ho Gab, executives and staff members of Nexen Central Research Institute.

Located at the Magok Industrial Complex in Seoul, Nexen Tire invested KRW 200 billion over two years to develop ‘THE NEXEN univerCITY’ -- a building over 57,000 square-meters with eight floors above and two floors underground --

that includes research and business complexes.

The workspace has been designed as an open innovation environment to maximize concentration and teamwork. To help pave the way for smarter technology, various facilities include a research and development (R&D) center that can predict and implement optimal performances such as OE/RE product manufacturing, AI technology and virtual tire technique, a performance research center to evaluate the performance of tires and vehicles, and a material research center to analyse diverse nano and macro dimensions on various materials.

With the establishment of these facilities, Nexen Tire plans to advance its R&D capabilities by responding quickly to the rapidly changing market as well as the particular demands of the local and global automotive industry. Furthermore, the Magok Central Research Institute will act as an R&D hub for its local and global R&D centres that are located in Yangsan, Changnyeong, Germany, the Czech Republic, U.S., and China. **T**





## MANN+HUMMEL Filter Cubes at the Neckartor traffic junction in Stuttgart now also reduce concentration of nitrogen dioxide

pollution. The assessments made so far have shown that the filters could help to reduce the local concentration of dust particles by between 10 to 30%.

Equipped with a newly developed combifilter medium from MANN+HUMMEL, the Filter Cubes III at the Neckartor traffic junction in Stuttgart now retain nitrogen dioxide from the ambient air in addition to fine dust. The retrofit in question is a temporary solution to reduce the concentration of nitrogen dioxide as quickly as possible. In August, all 17 Filter Cubes III will be replaced by further developed systems with a larger filter surface area and more powerful fans. In addition, MANN+HUMMEL will increase the total number of installations from 17 to 23. These measures will increase the impact compared to the temporary solution.

MANN+HUMMEL expects that the use of the filter cubes will lead to a reduction of between 10 to 30 percent for the local concentration of fine dust and also nitrogen dioxide. This corresponds to 40 percent of all the nitrogen dioxide and fine dust emissions which are generated by vehicles passing by the Neckartor traffic junction in Stuttgart. In the past, the limit value for nitrogen dioxide (40 micrograms per cubic meter on average throughout the year) was regularly exceeded at the "Am Neckartor" measuring station. **T**

**L**udwigsburg, April 24, 2019. The 17 Filter Cubes III from MANN+HUMMEL installed at the Neckartor traffic junction in Stuttgart are being retrofitted with technology which now reduces the concentration of nitrogen dioxide in addition to fine dust particles. In the past, the limit value for nitrogen dioxide was regularly exceeded at the "Am Neckartor" measuring station. In February, the filtration specialist had presented the technology for the reduction of nitrogen dioxide (NO<sub>2</sub>) at polluted locations at its company headquarters in Ludwigsburg. The innovation makes a contribution to protect human health and could remove the need for driving bans in inner cities. The Filter Cubes III from MANN+HUMMEL were installed at the Neckartor traffic junction at the end of last year to reduce fine dust

## 42 Groups Join Together to Help Lawmakers, City Officials and Business Leaders Develop 21st-Century Clean Transportation Network Offering More Options and Serving the Needs of All in the Northeast and Mid-Atlantic

Forty-two local, regional and national groups today launched a new coalition, Our Transportation Future, established to help Northeast and Mid-Atlantic states develop a regional clean transportation system that protects public health, curbs climate-changing pollution, expands economies and improves the flow of commerce. The coalition will support states efforts to address a transportation system that is unworkable, outmoded and is the leading source of carbon pollution driving climate change.

Our Transportation Future (OTF) is committed to finding solutions and modernizing transportation across the Northeast and Mid-Atlantic region. The coalition aims to help transform the region's transportation system into a model for the nation that gets people in rural, suburban and urban communities where they need to go safely, more efficiently and with less exposure to harmful pollution.

OTF experts are taking an active role to educate state policy makers and the media. The new OTF website will provide important news, information and announcements about the ongoing efforts to modernize transportation across the Northeast and Mid-Atlantic states. A monthly round-up of media coverage and commentary about regional clean transportation is available at OTF with a free subscription.

OTF supports the policy objectives of the Transportation and Climate Initiative (TCI), a collaboration of Northeast and Mid-Atlantic states and the District of Columbia working to reduce transportation pollution and invest in a modern, clean transportation future for the region. In December 2018, nine TCI states and D.C. committed to working over the course of 2019 to design and create a market-based program to limit transportation pollution while improving public transit, expanding electric vehicle use, establishing more bikeways and pedestrian walkways and fostering economic growth. **T**



## DHCV Launches CKD Operations of Tata Motors Vehicles in Malaysia

Following the successful launch of the Tata Super Ace and Tata Ultra truck range last year, DRB-HICOM Commercial Vehicles Sdn. Bhd. (DHCV), the authorised distributor of Tata Motors vehicles in Malaysia, together with Tata Motors Limited (Tata Motors) launched the local completely knocked down (CKD) assembly operations for Tata Motors vehicles.

The launch was marked by the roll out of Tata Super Ace and Tata Ultra 814 (7 500kg); and 1014 (10 400kg) trucks. The assembly launch is a strategic step towards pushing the sales and market share of Tata Motors range of products especially in the small pickup and light-duty truck segments in Malaysia. **F**

**FOTON** **MPIRE**

**FOTON C2 & CS2 SERVICE CAMPAIGN**

**SAVING UP TO RM 120.00**

T&C apply

**FREE AIR & OIL FILTER**

**CAMPAIGN START TODAY TILL 30th JUNE 2019**

**FREE 50 POINT CHECK**

## Mpire Runs Foton C2 and CS2 Service Offer

Mpire Asia is running a service package offer for the Foton C2 and Foton CS2 vans. Speaking to a representative of the company, we found out that the company decided to launch the campaign in order to increase public awareness on Foton products. Following the introduction of the Mpire Asia Sdn Bhd service network and a constantly striving to further improve Foton customers' ownership experience, the launch of this service campaign is seen as a timely move. To further entice customers to have their vehicles serviced by Mpire, the company's authorised service branch and dealers will be performing a 50-point safety inspection for free. On top of that, customers will enjoy free air oil filters worth RM 120 when sending their vehicle for maintenance during this campaign period. Customers can bring their vehicle to a wide network of authorised service centres located nationwide. For further information, please refer to the Foton Malaysia website. Campaign ends 30th June 2019. **F**



# ISUZU



# NEW

## ELF Smoother

## FORWARD FVR300

6<sup>th</sup> ELF Anniversary



### INTRODUCING THE NEW ELF SMOOTHER

AND

### THE CLASS-LEADING POWERFUL FVR300

R  
N  
D  
4<sup>+</sup>  
M

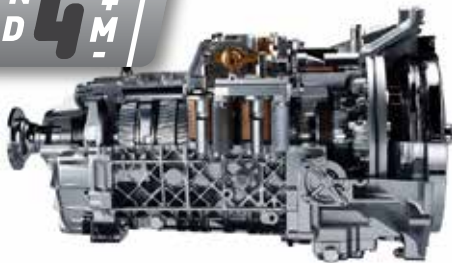

(ABS)

... FULL AIR BRAKE ...  
AUTO ADJUSTER



EURO



FREE SERVICE CAMPAIGN  
UP TO 100,000km\*  
ISUZU

WARRANTY  
3 YEARS  
100,000km

WARRANTY  
5 YEARS  
150,000km

ISUZU DOCTOR MOBILE  
24

Reliable support with round-the-clock business operation.

1-800-88-8000

For more information, log onto [www.isuzu.net.my](http://www.isuzu.net.my)

ISUZU MALAYSIA SDN BHD (664946-H) HOTLINE: 1-300-88-1133 GENERAL LINE: 03-7723 9777 FAX: 03-7723 9779

ISUZU SERVICE CENTER SDN BHD (1205672-X) Lot 730, Jalan Sungai Rasa, Seksyen 17, 40200 Shah Alam, Selangor Darul Ehsan TEL: 603-5513 0518 FAX: 603-5512 7550

# F U S O

## ALL FOR YOU

### CONTEST



Buy a FUSO truck today and stand a chance to drive away with a Mercedes-Benz C200, and win other prizes worth more than RM330,000\*!

\*Terms & conditions apply.

MITSUBISHI FUSO Authorized Distributor:  
Hap Seng Trucks Distribution Sdn. Bhd. (1250643-T)  
No. 1, Jalan Kinrara 2, Taman Perindustrian Bandar Kinrara,  
41780 Puchong, Selangor, Malaysia.

 03-8082 9160/9120

 03-8082 9121

 [www.fuso.my](http://www.fuso.my)

DRIVING YOUR BUSINESS



MITSUBISHI FUSO authorized distributor

**HAP SENG**  
TRUCKS DISTRIBUTION