

ISSUE 53, May / June 2020
RM10.00

ISSN 2150-382X
9 772183 154200
KDN PP18693/12/2017 (034826)

ASIAN TRUCKER

www.asiantrucker.com

MALAYSIA



TOTAL SOLUTION FOR YOUR COMMERCIAL FLEET



1 ton

3 & 5 ton

18 Seater
Window Van

Panel Van

JAC
MOTORS

FOTON DAIMLER
AUTOMOTIVE

FOTON



MPIRE AUTO SDN BHD

+603 7865 5999 info@mpiregroup.com.my

https://mpiregroup.com.my/

No.2, Jalan 51/225A, Zon Perindustrian PJCT, Sek 51A, Petaling Jaya, Malaysia



THE ULTIMATE SIDELOADER CHOICE

- + Handle 20', 2x20', 40' or even jumbo 45' containers
- + Lightest tare weight in the world, save 2000-3000 kg! Fuel savings every kilometer
- + 1 to 45 tonnes payload, same handling time of 3,5 minutes! Same speed no matter payload
- + High quality Swedish tech combined with Malaysian expertise
- + 100% spares in stock, 24 hrs back-up service 365 days around
- + PTO or 84 HP Engine Power Pack option

Hammar is the world leading Sideloader manufacturer, with Sideloaders sold in more than 116 countries. We have local offices in Malaysia, Sweden, Australia, New Zealand, USA, Vietnam, South Africa and Brazil, and 48 local service agents world-wide.



5 Years Warranty

Terms and conditions apply





NBG INDUSTRIES SDN BHD (1052500-M)

No.133, Lot 7955, Jalan Sungai Buloh, Kampung Baru Subang,
Seksyen U6, 40150 Shah Alam, Selangor.

Tel: +603-7859 9533 / +603-7859 8533 Fax: +603-7859 7833

Facebook: FAW Trucks Malaysia



**YOUR
COMMERCIAL
VEHICLES
PARTNER**

您的商用車伙伴



PRODUCT DISTRIBUTOR

WABCO

Valeo

Continental
ContiTech
PHOENIX
Air Springs

**MANN
FILTER**

EURO-Technic

FERODO[®]
THE FIRST NAME IN BRAKES

AFTER SALES SERVICE AGENT

WABCO



Fast

WEICHAI
维柴



YUCHAI

HIGER

TRUCK DISTRIBUTOR

SHACMAN

YONMING[®] GROUP SDN BHD

603 - 6251 9448

ymhq@yonming.com

www.yonming.com



**OPERATE WITH ADEQUATE SAFETY PROCEDURES IN PLACE
FOR YOUR HEALTH & SAFETY.**



FEEL THE **DIFFERENCE** FROM OTHERS

不一樣的質量



X3000
Optimize



Well Established
Malaysia Network



Guarantee Spare
Parts Availability
with Warranty



24 Hours
RES-Q Team

GREATEST INVESTMENT EVER.

WWW.SHACMAN.COM.MY

DISTRIBUTED BY

SHAANXI TRUCKS SDN BHD

201101034481 (962614-K)

MEMBER OF  **YONMING GROUP**

CONTACT PERSON

Mr. Kau Chez Ching

+ 601 2282 2948

+ 603 3166 3880

Lot 40778, Lorong Gerudi 1, Off Jalan Pelabuhan Utara, 42000 Port Klang, Selangor, Malaysia



**OPERATE WITH ADEQUATE SAFETY PROCEDURES IN PLACE
FOR YOUR HEALTH & SAFETY.**



FOTON



Foton Total Care

Backed by Tan Chong's Group service network



Vast Service
Network

Distributor for Foton Trucks:



ANGKA-TAN MOTOR SDN BHD (85810-A)
(A subsidiary of Warisan TC Holdings Berhad) 华丽山陈唱子公司

No. 117-119, Jalan SS15/5A, 47500 Subang Jaya, Selangor Darul Ehsan, Malaysia
Tel: 03-5638 6888 Tel: 03-5632 9668
Website: www.angkatanmotor.com.my

TECHNOLOGY LEADING INTO THE *FUTURE*



**Driver
Development
Training**



**Provide
Genuine Parts**



**24
HOUR Breakdown
Service**
RES-Q

**24/7 Breakdown
Service**



**One-Stop Repair
& Insurance
Service**

Master Dealer: TC Trucks Sales Sdn Bhd

Batu Caves Tel:03-61891896 • Bukit Mertajam Tel: 04-5381308 • Ipoh Tel: 05-2921028 • Johor Bharu Tel: 07-3538808 • Klang Tel: 03-31669609 • Melacca Tel: 06-3366957 • Sabah Tel:088-499228 • Sarawak Tel:082-488811

Authorized Dealers:

Combine Motor Sdn Bhd Tel: 03-61363060 • Commercial Junction (M) Sdn Bhd Tel: 07-4333998 • Derchin Auto Sdn Bhd Tel: 07-3864108 • Edaran Setia Auto Sdn Bhd Tel: 09-5162288 • Element Autolink Tel: 03-77728363 • Kee Huat Auto Sdn Bhd Tel: 04-6265031 • Liong Seng & Son Trading Sdn Bhd Tel: 03-33741998 • LK Utara Auto Sdn Bhd Tel: 04-7339098 • O.C.T.C (M) Sdn Bhd Tel:03-33430779 • P&C Automobile Sdn Bhd Tel:012-3362162 • Power Genius Sdn Bhd Tel: 03-58850823 • Saga Superior Sdn Bhd Tel: 05-3227221 • Taycn Kredit Sdn Bhd Tel:06-6787760 • Urban Truck & Services Sdn Bhd Tel: 012-6237603 • Wiramas Motor Trading Tel: 07-9317233 • Zep-Zhuan Trading Sdn Bhd Tel:09-5676066

STEELBRO

CONTAINER HANDLING SOLUTIONS

New Release for 2020 – SB450 45T Sidelifter Facelift Model



We have gone the extra mile with the new SB450 heavy duty model, further enhanced with exceptional performance, quality and cost effective solution for your container handling solutions.



- Aluminium mudguard and LED tail bar provides sporty, long lasting design
- Additional safety features with LED emergency beacon light and LED rear licence lamp
- 4 extra LED working lights for night operation
- Additional decals for safety compliance on the road
- Rear control box double protection for safety and theft
- Strong side guard protection
- Electrical Caterpillar track support
- RNM – Repair and Maintenance contract is available for engines and side loader cranes
- Latest V2403 Kubota engine with higher HP and improved performance
- Better mileage and less down time with OEM approved long life coolant and premium grade engine oil
- Extra protection with metal cover for radiator and fan
- Light weight durable lifting chains for heavy duty operation
- Smart leg sensor for safety and stability
- Proportional landing leg with reinforced support

T & C Apply. Please contact STEELBRO Malaysia sales team for further details on the product and sales packages

The World's Best Valued Sidelifter

STEELBRO (M) SDN BHD (303253-W)
Lot 2, Jalan Sultan Hishamuddin 2
Kawasan Perusahaan Selat Klang Utara
42000 Port Klang, Selangor, MALAYSIA
General Phone: +603 3 176 3833
www.steelbro.com

STEELBRO SALES
Sales Mobile: +60 19 383 3686
Sales Admin: +60 19 624 2833
Email: sbmsales@steelbro.com

Ensure the reliability and lifetime of your Steelbro sidelifter with genuine parts and expert maintenance. Steelbro stands behind its Sidelifters.



Genuine Steelbro Spare Parts

A range of parts are available for current Steelbro product lines. Damaged items are easily replaced – we make steel fabricated parts to order. Talk to our friendly staff, and they will help to identify and fulfil your parts requirements.



Service and Support

Regular servicing ensures cost effective running of your sidelifter. We provide a nationwide network of workshop based services plus 24/7 mobile support within the Central Region.



Warranty

The Steelbro product is backed up by a 36 month warranty on crane structure giving you peace of mind. Steelbro components are sourced from internationally recognised manufacturers ensuring commitment to quality, availability and support worldwide.



Maintenance and Repairs

Maintenance and repair work expertly managed by the Steelbro Team. We offer repair and maintenance contracts (RNM) for all our new and existing units. Please check the details with our sales team.



Training

Certified operator training is delivered by Steelbro trainers for new Sidelifter purchases. Refresher training provided upon request.



Trade-In / Refurbishment

We offer a trade-in and refurbishment service to ensure your fleet is always running at optimum efficiency.

STEELBRO PRODUCT SUPPORT
3S Service Provider for Central Region (KL & Selangor)
Service Support: +60 19 358 7833
Part Support: +60 19 273 4833
Technical Support: +60 19 274 7833
Admin & Appointment: +603 3176 3833 ext 105
Email: sbmservice@steelbro.com

2S Service Provider Northern Region (Penang & Perak)

AF Mutiara venture
Phone: +604 575 1181
Mobile: +60 12 475 8909

2S Service Provider East Malaysia Region

Intercargo Sdn. Bhd.
Direct Line: +60 86 253 359
Mobile: +60 19 884 3359

2S Service Provider Southern Region (Johor & Singapore)

XINHWA Auto Engineering Sdn. Bhd.
Phone: +607 590 0875 Mobile: +60 12 779 4223



STEELBRO



CAMC Heavy-duty Truck, European Standards Definition of new criteria for heavy-duty truck

CAMC new generation heavy-duty trucks are developed by Anhui Hualing Automobile Co. Ltd. by applying world advanced heavy-duty truck technology.

It is powered by high performance common-rail engine with low fuel consumption and high power, complying with Euro III emission standard.



CAMC

DA DEAUTO INDUSTRIES SDN BHD (881055-M)

4x2
6x2
6x4

PRIME MOVER



Engine
Hino P11C- 350Hp
Hino P11C- 380Hp
Cummins ISMe
420-30 -420Hp

Transmission
ZF Friedrichshafen
AG. 9/16 speed

Chassis
Double Layer

Rear Axle
Hub Reduction

6x4
8x4

MIXER TRUCK



Engine
Hino P11C- 350Hp
Hino P11C- 380Hp

Transmission
ZF Friedrichshafen
AG.

Chassis
Double Layer

Rear Axle
Hub Reduction

4x2
6x2
6x4
8x2
8x4

RIGID TRUCK



Engine
Hino P11C- 350Hp
Hino P11C- 380Hp
Cummins ISMe
420-30 -420Hp

Transmission
ZF Friedrichshafen
AG. 9/16 speed

Chassis
Double Layer

Rear Axle
Hub Reduction

VOLVO ACTIVE SAFETY PACKAGE

YOUR PARTNER FOR A SAFER DRIVE



Active Safety System can provide better protection for the driver and other road users. The system aims at preventing blind spot accidents, keeping the truck in the correct lane and actively avoiding collision with other vehicles.

Now you can find us on



STEERING AND CONTROL



Adaptive cruise control with forward collision warning and emergency brake

A result of Volvo Trucks' pioneering work with Active Safety systems, our radar and camera-based *Adaptive Cruise Control* helps keep a safe distance from the vehicle in front by controlling the accelerator and all available brakes.

Upon the risk of impact, our intuitive *Collision Warning System* alerts you by projecting a light onto the windscreen so that it does not go unnoticed. The *Emergency Brake* then automatically activates, significantly reducing the risk of severe injuries, so as to avoid or mitigate rear-end collisions.



Volvo Dynamic Steering

Providing perfect stability at high speeds, total control at low speeds and reduced the strain on your muscles. This is all possible with the *Volvo Dynamic Steering (VDS)* system where a control system and a powerful electric motor assist the hydraulic steering gear. The *Volvo Dynamic Steering* reduces steering force up to 85%.

The *Stability Assist* helps the drivers to keep control of the vehicle when the truck starts to skid. Set your preferred steering wheel settings and enjoy the freedom of controlling your steering remotely for a relaxed driving experience.



1. Prevent blind spot accidents

When the turn signal is activated, our *Lane Changing Support* uses radar technology to scan the blind spot on your passenger side for other road users. You will be alerted with a buzzer and a flashing icon next to the passenger mirror if it's not safe to change lanes.



2. Alert drivers

Our *Driver Alert Support* is an intelligent system that monitors driving behaviour and detects driving characteristics of drowsy or inattentive drivers. If it differs from normal and indicates tiredness, you will be alerted by a signal and a message in the display, advising you to take a break.

3. Track lanes

Drifting out of lane is a common cause of serious accidents. Our *Lane Keeping Support system* tracks road markings with a camera, and alerts you if you unintentionally cross them. This way, you will never go over the driving lane again.

With *Lane Keeping Assist*, the truck will alert the driver and automatically make necessary correction if the truck continues to deviate from the driving lane and there is no reaction from driver.

SUPPORT SYSTEMS

Developed to enable better traffic safety and enhanced working environment on the road, here's what our driver support systems can do with the new Volvo FH series for the best protection yet.

During reversing, our *Back-up Monitoring system* offers excellent visual supervision behind the truck. The camera activates as soon as the reverse gear is engaged, giving you a clear picture of the reversing area on screen.



Your drive with Volvo Trucks is now even safer.

Call us today at 012-373 1030/ 019-240 1030, visit www.volvotrucks.my or www.facebook.com/VolvoTrucksMalaysia for more information.

Volvo Trucks. Driving Progress



SOUTH EAST ASIA'S LARGEST COMMERCIAL VEHICLE EXHIBITION

17- 19 June 2021. Apply for a booth now to avoid
disappointment! Contact us via
info@asiantrucker.com
+60 12 207 2344





Organised by



Asian Trucker Exhibition Sdn Bhd
No. 27-1, Block C, Zenith Corporate Park, Jalan SS7/26 Kelana Jaya,
47301 Selangor, Malaysia
Email: info@asiantrucker.com Web: www.mcve.com.my

CONTENTS



30 - EDITOR'S NOTE

MARKET UPDATE

- 32** - First Fully Electric Truck Mixers from Liebherr and Designwerk
- 34** - Isuzu GIGA Trucks set to Strengthen Nippon Express (Malaysia) Sdn Bhd
- 36** - PETRONAS Launches PETRONAS Lubricants Toolbox
- 38** - Gran Max Makes Grand Impression in Tough Times
- 40** - Enhanced Sidelifter Ticks All the Boxes for Haulage Company with a Furnishing History





中国重汽
SINOTRUK



Sendok Group



T7H AMT
AUTO MANUAL TRANSMISSION
430HP

5 YEARS
UNLIMITED
MILEAGE
WARRANTY

*Terms & Conditions Apply

LIGHT WEIGHT • POWERFUL • LONG OIL CHANGE INTERVAL • ECONOMY • HIGH RELIABILITY

Sinotruk by Sendok Group. 11 Years in Malaysia



Sendok Group
www.sendokgroup.com

HEADQUARTERS

Sendok Group Building, Lot 1564, Batu 4, Jalan Kapar, 42100 Klang, Selangor Darul Ehsan
Tel : +603-3345 5600 | Email: info@sendokgroup.com

LET'S TALK WITH US!

Klang	Tel: 019-268 1430 (Mr. Alan) / 019-577 3001 (Mr. Loo)	Johor Bahru	Tel: 012-788 2555 (Mr. S.K. Tan) / 07-380 8296
Kuantan	Tel: 012-957 7366 (Mr. Lee) / 09-536 1688	Bintulu	Tel: 019-963 1319 (Mr. A.K.) / 086-339 136
Kota Bharu	Tel: 019-268 1430 (Mr. Alan)	Sibu	Tel: 016-860 4069 (Mr. Goh) / 084 -336 160
K. Terengganu	Tel: 019-983 3024 (Rahmat) / 09-624 9588	Sandakan	Tel: 013-880 0691 / 013-888 6123 (Mr. William)

CONTENTS



48

EVENTS

- 42 - CAPAS Defers to 2021
- 44 - JOSAM Aligns Precision with Efficiency

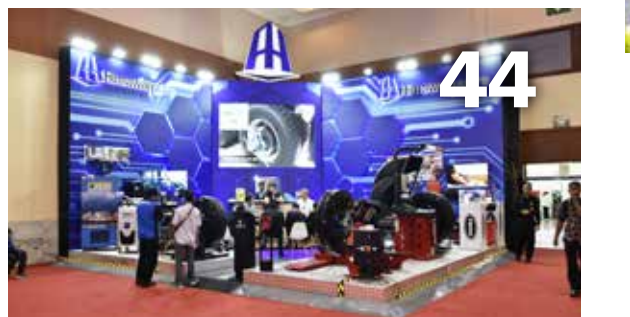

44

COVER STORY

- 48 - To Build a Mpire

TRAILER TECH

- 52 - How to make a High-performing Semi-Trailer

ASIAN TRUCKER DRIVERS CLUB

- 55 - Trucking Community Comes Together to Help Drivers



52



Actros 5. Coming soon.

Register your interest at www.trucksdistribution.com.my

Mercedes-Benz
Trucks you can trust.



 **HAP SENG
TRUCKS DISTRIBUTION**

General Distributor of Daimler Trucks

Hap Seng Trucks Distribution Sdn. Bhd.

1, Jalan Kinrara 2, Taman Perindustrian Bandar Kinrara, 47180 Puchong, Selangor

(03) 8082 9160

hstd.inquiry@trucksdistribution.com.my

www.trucksdistribution.com.my

Authorised Sales & Service Dealers:

• **Johor:** Cycle & Carriage Bintang Bhd (Johor Bahru) (07) 238 2299 • **Pahang:** Hap Seng Trucks Sdn Bhd (Kuantan) (09) 566 2268 • **Penang:** Hap Seng Trucks Sdn. Bhd. (Prai) (012) 485 2889
• **Perak:** Cycle & Carriage Bintang Bhd. (Perak) (05) 354 1819, Hap Seng Trucks Sdn Bhd (Ipoh) (05) 292 2278 • **Sabah:** Hap Seng Trucks Sdn Bhd (Kota Kinabalu) (088) 435 043
• **Sarawak:** Hap Seng Trucks Sdn Bhd (Kuching) (082) 356 886, Hap Seng Trucks Sdn Bhd (Miri) (085) 651 699 • **Selangor:** Cycle & Carriage Bintang Bhd (Batu Caves) (03) 6192 9200,
Hap Seng Trucks Sdn Bhd (Kinrara) (03) 8071 1588, Hap Seng Trucks Sdn Bhd (Klang) (012) 201 4969, Q-Team Sdn Bhd (03) 3176 6088

Authorised Service Dealer:

Melaka: Rick Huat Workshop Sdn Bhd (06) 336 2978

CONTENTS



58

TRUCKER OF THE MONTH

56 - The Road to Happiness is Paved with Passion

FEATURE STORY

58 - MAN Launches The Best MAN Ever

TECH TALK

62 - Adding Blue to Go Green





PETRONAS

Championing your truck's transmission. A true Hidden Hero.

PETRONAS *Tutela*®

Championing the Hidden Heroes.

Always ready, always precise, always accurate – the PETRONAS Tutela family of technologically advanced transmission fluids has been engineered to champion and defend the unsung, performance-critical transmission system

Find out today how PETRONAS Tutela could maximise your truck's performance.



CONTENTS



SPECIAL REPORT

64 - Waste Collection Trucks as Essential Tools in a Crisis

TRUCK FEATURE

68 - With Inner Vision Opened, Horizon Group Expands



Light you up



EXPAND YOUR BUSINESS
THIS RAYA WITH

DAIHATSU
GRAN MAX

Lightweight & Compact, Durable & Versatile, an all rounder **Gran Max** is the ideal transport means to run your Raya businesses. From catering and delivering of Raya delicacies, to business on wheels pop-up events and more, it doesn't get any better than this!



Visit nearest authorized Daihatsu showroom or

Access Daihatsu e-Showroom Today!

Step 1



Browse our Daihatsu Gran Max models and check out any latest promotions

Step 2



Fill in your detail in the Sales Booking Form.

Step 3



Once completed, click on the Submit button.

Step 4



Our friendly Sales Advisor will get in touch with you for next steps.



Scan Here for
Daihatsu e-Showroom



CONTENTS



THOUGHT LEADERS

70 - The Talented Volvo Trucks Malaysia

TRUCKING HISTORY

72 - Malaysia – Special Purpose Vehicles

73 - SCHEUERLE Trailer Still in use at Flückiger after 56 Years



**MANN
FILTER**

Cleaner Air, Healthier You.

FreciousPlus – the biofunctional cabin air filter for trucks that blocks PM2.5, nitrogen oxides and allergens



**Now for
selected truck
models!**

Switch your cabin air filter to MANN-FILTER FreciousPlus for extra protection and higher productivity as you enjoy cleaner air on the move.

A truck journey can quickly become absolute torture if exhaust gases, pollutants and allergens penetrate into the driver's cab. Conventional cabin air filters only prevent the ingress of particles such as dust, pollen, diesel soot and unpleasant odors. The biofunctional FreciousPlus from MANN-FILTER now provides for additional comfort and safety: it binds virtually 100% of allergens and stops bacteria, molds and fungi, as well as particulate matter such as PM2.5 almost completely. More information is available at www.frecious-plus.com/en



MANN-FILTER - Perfect parts. Perfect service.
www.mann-filter.com

CONTENTS



74

COMPANY PROFILE

74 - Huajing got your Trailer Parts

TYRE TECH

76 - The Truth About Retreads

HEADLIGHTS

79 - There is Always Room for Improvement

80 - NEWS & NOTES



76

ISUZU

ELF



GREAT THINGS COME IN TWOS IN 2020

EXTENDED TO 200,000km*



*Terms and conditions apply



ISUZU MALAYSIA SDN BHD 200401026438 (664946-H) HOTLINE: 1-300-88-1133 GENERAL LINE: 03-7723 9777 FAX: 03-7723 9779

ISUZU SERVICE CENTER SDN BHD (1205672-X) Lot 730, Jalan Sungai Rasa, Seksyen 17, 40200 Shah Alam, Selangor Darul Ehsan TEL: 603-5513 0518 FAX: 603-5512 7550

Peninsular Malaysia Authorised Dealers: **KEDAH** • Indah Utara Sdn. Bhd. (Alor Setar) - 04-735 1111 • Indah Utara Auto Sdn. Bhd. (Sungai Petani) - 04-431 8788 **PULAU PINANG** • Automotive Corporation (M) Sdn. Bhd. (Prai) - 04-501 1888 • Indah Utara Auto Sdn. Bhd. (Bukit Mertajam) - 04-506 1888 **PERAK** • Automotive Corporation (M) Sdn. Bhd. (Ipoh) - 05-318 8000 • Weng Fatt Otomobil Sdn. Bhd. (Ipoh) - 05-254 0992 • Weng Fatt Otomobil Sdn. Bhd. (Sitiawan) - 05-691 8996 **KUALA LUMPUR** • Autoexec Corporation Sdn. Bhd. (Kuala Lumpur) - 016-226 5543 • Metro Otomobil Sdn. Bhd. (Kepong) - 03-6251 7319 **SELANGOR** • Automotive Corporation (M) Sdn. Bhd. (Batu Caves) - 03-6188 1133 • Automotive Corporation (M) Sdn. Bhd. (Shah Alam) - 03-5513 0160 • Continental Top Motors Sdn. Bhd. (Seri Kembangan) - 03-8942 7010 • Igreen Generation Sdn. Bhd. (Petaling Jaya) - 03-7880 5969 • PTM Accel Sdn. Bhd. (Sungai Buloh) - 03-6188 6162 • SV Prestige Auto Sdn. Bhd. (Puchong) - 03-8068 9911 • SV Prestige Auto Sdn. Bhd. (Balakong) - 03-9082 1112 • VS Automotive (M) Sdn. Bhd. (Rawang) - 03-6093 6995 • Ultra Gallant Sdn. Bhd. (Klang) - 03-3165 9755 **NEGERI SEMBILAN** • Ultra Gallant Sdn. Bhd. (Nilai) - 06-850 2960 • Ultra Gallant Sdn. Bhd. (Seremban) - 06-677 9903 **MELAKA** • Ng Hup Lee Motors Sdn. Bhd. (Peringgil) - 06-283 4755 **JOHOR** • Automotive Corporation (M) Sdn. Bhd. (Johor Bahru) - 07-352 1333 • Jumbo Arena Sdn. Bhd. (Batu Pahat) - 07-435 5666 • Jumbo Arena Sdn. Bhd. (Kluang) - 07-772 2248 • Key Power Motor Sdn. Bhd. (Johor Bahru) - 07-234 7080 • Jumbo Arena Sdn. Bhd. (Segamat) - 07-931 2266 • Ng Hup Lee Motors Sdn. Bhd. (Muar) - 06-959 4520 **PAHANG** • Automotive Corporation (M) Sdn. Bhd. (Kuantan) - 09-512 6868 • Dynamic Motors Sdn. Bhd. (Kuantan) - 09-566 8898 • Pacific Motor Sdn. Bhd. (Temerloh) - 09-290 1722 • Pacific Motor Sdn. Bhd. (Raub) - 09-355 8577 • Weng Fatt Otomobil Sdn. Bhd. (Cameron Highland) - 05-691 8996 **KELANTAN** • T.E.C United Auto Sdn. Bhd. (Kg Tapang, Kota Bharu) - 09-764 8385 • T.E.C United Auto Sdn. Bhd. (Taman Maju, Kota Bharu) - 09-748 5888 • T.E.C United Auto Sdn. Bhd. (Tanah Merah) - 09-950 3898 **TERENGGANU** • Yeow Lee Commercial Sdn. Bhd. (Kuala Terengganu) - 09-622 6758

East Malaysia Authorised Dealers: **SABAH** • Fook Loi Automax Sdn. Bhd. (Kota Kinabalu) - 088-313 898 • Universal Motor Sdn. Bhd. (Lahad Datu) - 089-886 118 • Universal Motor Sdn. Bhd. (Kota Kinabalu) - 088-388 920 • Universal Motor Sdn. Bhd. (Sandakan) - 089-272 600 • Universal Motor Sdn. Bhd. (Tawau) - 089-775 500 • Universal Motor Sdn. Bhd. (Keningau) - 087-335 505 **SARAWAK** • Hornbill Motor (Limbang) - 085-215 296 • Rhino Motors Sdn. Bhd. (Kuching) - 082-452 444 • Dai Max Automobile Sdn. Bhd. (Kuching) - 082-424 855 • Rhino Motors Sdn. Bhd. (Sibu) - 084-344 444 • Dai Max Automobile Sdn. Bhd. (Sibu) - 084-212 113 • KM Mobil Sdn. Bhd. (Bintulu) - 086-318 668 • KM Mobil Sdn. Bhd. (Miri) - 085-663 355

For more information, log onto www.isuzu.net.my

The Drivers **ASIAN TRUCKER**

**YOUR GUIDE TO ALL
THINGS TRUCK**

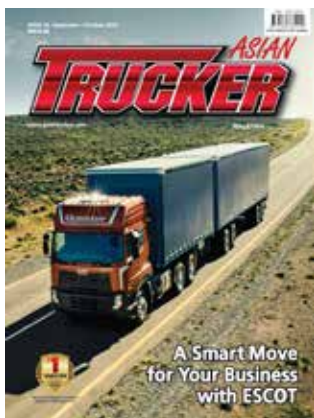
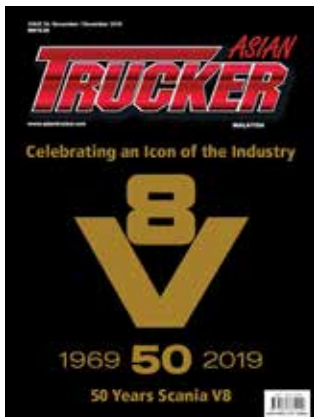
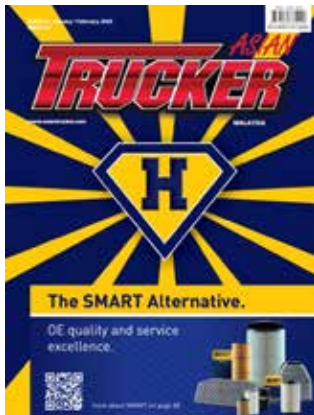

PDF versions are
available for
download at
www.asiantrucker.com

EDITORIAL

EDITOR Stefan Pertz
WRITERS Carol Yeoh
Aila Azizul
GRAPHIC DESIGNER Tony
PHOTOGRAPHERS Floyd Cowan
Carol Yeoh
Stefan Pertz
Aila Azizul

CONTRIBUTORS

Floyd Cowan
Giovanni Siano

ADVERTISING

Nicole Fong
Nicole@asiantrucker.com

SINGAPORE

Floyd Cowan
Floyd@asiantrucker.com

THAILAND

Songyot Kamontavikun
Songyot@asiantrucker.com

ASIAN TRUCKER DRIVERS CLUB

Sponsorship / Membership
info@asiantruckerclub.com.my

CIRCULATION, CONTRIBUTIONS and SUBSCRIPTION

info@asiantrucker.com WEBSITE and E-NEWSLETTER
www.asiantrucker.com

PUBLISHED BY

Asian Trucker Media Sdn. Bhd. No. 27-1, Block C, Zenith Corporate Park,
Jalan SS7/26 Kelana Jaya, 47301 Selangor, Malaysia www.asiantrucker.com

ARTICLES

Asian Trucker is a registered trademark of Asian Trucker Media Sdn. Bhd. All articles submitted for publication become the property of the publisher. The editor reserves the right to adjust any article to confirm with the magazine format.

Asian Trucker is a bi-monthly publication. The publisher will not be responsible for any copyright violation of articles that have been approved by contributing writers. The publisher accepts no responsibility for unsolicited manuscripts, illustrations or photographs.

PRINTED IN MALAYSIA

Times Offset (M) Sdn Bhd Banguan Times Publishing,
Lot 46, Subang Hi-Tech Industrial Park Batu Tiga 40000 Shah Alam,
Selangor Darul Ehsan Malaysia

Boost your business with a listing on our new website.

**Find businesses or sell your truck, upload your events or images to the gallery.
Visit our new website www.asiantrucker.com to put your company on speed.**

EXCITEMENT COMING **SOON.**



The Lion roars in Port Klang.

With the new MAN service centre opening soon in Port Klang, you will never be far from MAN's comprehensive range of After Sales services. The best solutions are often very simple. It is coming closer to where you are.
www.man.com.my





stefan@asiantrucker.com



The implementation of the EURO V emission norms is an agenda item of the Malaysian Automotive policy. Maybe there will be a postponement, but nevertheless, we should all be prepared for this. Eventually, this new technology will make an entrance and transporters will have no other options for their engines. In this issue, you will find a technical discussion on this. I have also had the pleasure of working on an article that clears up some misconceptions on retreaded tyres. Somehow, that doesn't go away and the non-trucking population still eyes them with suspicion.

if you are planning to replace your trucks or add to the fleet. Turn to our feature story to get to know these trucks.

With every article I write, I learn something. For this issue we dug into the business of waste collection and what we found out might also surprise you. I have further learned a lot about hydrogen fuel cells and new applications that help fleet owners with anything and everything related to lubricants.

I have often said it and it is still true that innovations are key to business success. In our cover story we feature a company that seems to be jumping from one innovative idea to the next. Deriving from there, we are also adding a new online tool to our staple of services. I encourage you to head on over to our website as we have done some amends there. In some cases I am not convinced that a new way of doing things is always better. For instance, a recent Zoom call took 20 minutes whereby it could have been put into an email with only two lines. However, if we don't try things in road transportation, we will not advance, and advance we must.

Urging you all to be safe at all times, I hope to be able to meet you all soon again. In the meantime, I hope that the material we have produced in this issue will be of use to you as there is more to the current business environment than a Movement Control Order.

Stay safe, drive safe!

Stefan Pertz
Editor, Asian Trucker Malaysia

Cabin Fever?

Hello from the home office! It has been a few weeks that we have now hunkered down and people adapted the work from home idea. I wonder how you all feel, being confined to your homes, working in a small space without much contact to others. I am asking, because that is what the average long distance trucker would feel. Right now, we might appreciate them more as we learned how we have to cope in a confined environment. And that should be as much reflecting as I will be doing on the current circumstances we face due to the pandemic.

Although I have not seen one of the new MAN trucks live, I was told that it is the best a MAN could have become. While I am personally not aware of the date for the introduction to Malaysia, we can be sure that it will not take too long before this new model arrives on our shores. We should all be prepared for that too. Especially





SCANIA ECOLUTION MAKES THE BEST BETTER

Naidu Trans Logistics Sdn Bhd, a good company that has reduced 35,000 kg of CO₂ with Scania Ecolution. To date, the company's reduced CO₂ emissions is equivalent to planting approximately 1,590 trees that have been flourishing for the past one year.

Scania Ecolution is a partnership between Scania and customers like Naidu Trans Logistics Sdn Bhd that aims to reduce fuel consumption and CO₂ emissions.

For more information about Scania Ecolution, call **+603 7945 1000**, email **smyenquiries@scania.com.my** or visit **www.scania.com.my**

 [fb.com/scania.malaysia.sdn.bhd](https://www.facebook.com/scania.malaysia.sdn.bhd)

 [linkedin.com/company/scaniamalaysia](https://www.linkedin.com/company/scaniamalaysia)

 [instagram.com/scaniamalaysia](https://www.instagram.com/scaniamalaysia)

SCANIA

Scania (Malaysia) Sdn Bhd 20000101599 (518505-D), No.1 Jalan Tiang U8/93, Bukit Jelutong Industrial Park, 40150 Shah Alam, Selangor D.E. Malaysia

Scania pursues an active policy of product development and improvement. For this reason the company reserves the right to change specifications without prior notice. Furthermore, due to national and legal requirements, some accessories may not be available in local markets. For further information in these respects, please contact your local dealer or visit www.scania.com.my



First Fully Electric Truck Mixers from Liebherr and Designwerk

The fully electric truck mixer on a 5-axle chassis is a emission-free and quiet concrete transport. First operations in Switzerland are expected to start in autumn 2020.

Liebherr and Designwerk have developed the first fully electric truck mixers with 10 and 12 cubic meter drums on a 5-axle chassis. The first operations are planned for our customers Holcim and KIBAG in Switzerland. This design is perfect for Switzerland, where vehicles with a gross vehicle weight of 40 tonnes are allowed to drive on 5 axles.

Concrete production in the concrete plants is clean and environmentally friendly, as the mixing plants operate electrically. This is not yet the case when transporting the concrete to the construction site: Up to now, powerful diesel engines have been the norm for such applications - combined with emissions in terms of exhaust gases and noise.

The new ETM 1005 and 1205 truck mixers on a chassis from Futuricum will change that: They transport large quantities of concrete to the construction site quietly and reliably without exhaust emissions. Since distances from the concrete plant to the construction site are relatively short compared to freight traffic, this all-electric solution is particularly well suited for this application. Moreover, the vehicles return to the concrete plant again and again, where there is a charging infrastructure for the batteries. Thanks to large accumulator capacities, charging the batteries is normally only necessary overnight. The Futuricum chassis is extremely powerful, with the equivalent of 680 HP, and can easily cope with the weight of the concrete. Energy recovery during braking or downhill driving further increases the range of the truck and reduces operating and maintenance costs. The drum drive developed by Liebherr and ZF consists of a low-maintenance and efficient unit of electric motor and mixer gearbox.

For the first time, both the truck and the truck mixer body are powered jointly by the traction battery, eliminating the need for costly power electronics components. The new Liebherr Generation 05 electrified body offers further advantages: The compact electric drive for the mixing drum is flanged directly to the drum and its high efficiency ensures that power consumption for relieving the traction battery of the Futuricum truck remains low. It also eliminates the need for any hydraulic equipment - no hose connections, no pump, and therefore no risk of leakage. Liebherr's truck mixer body boasts a low net weight combined with the best possible transport volume, a long service life thanks to its special wear-resistant steel and the ergonomic design of the operation system and access points. A platform system on both sides allows flexible positioning and attachment of accessories or attachments to suit customer requirements.

A successful overall concept

All subassemblies, chassis and mixer bodies are optimally matched to each other by Liebherr and Futuricum. The weight distribution across the axles is ideal for very good driving characteristics. A temperature management system ensures that the components are cooled or heated as required. The ETM 1005 and 1205 on Futuricum chassis are a real breakthrough when it comes to environmentally friendly concrete transport. **F**

Hengst[®]
FILTER



The SMART Alternative.

OE quality and service
excellence.





Isuzu GIGA Trucks set to Strengthen Nippon Express (Malaysia) Sdn Bhd

Just before the Movement Control Order came into effect, Isuzu Malaysia Sdn Bhd held a handover ceremony to commemorate the procurement of Isuzu GIGA GXR360 container trucks by Nippon Express (Malaysia) Sdn Bhd. The handover ceremony took place at Nippon Express (Malaysia) Sdn Bhd's Johor branch.

The GIGA Prime Mover trucks were procured through Key Power Motor Sdn Bhd, Isuzu Malaysia's authorised dealer based in Skudai, Johor.

Nippon Express (Malaysia) Sdn Bhd provides customised logistics solutions and high-quality services according to business needs. Some of the services that the company offers include transportation of products and related services, specialised transport, supply chain management, and warehouse and distribution.

The two newly procured units of the Isuzu GIGA GXR360 trucks, which feature a corrugated box body, are the latest additions to Nippon Express Malaysia's current transportation fleet. These units will be based at Nippon Express' Johor Bahru branch. However, it is expected that logistics operation of these two units will cover areas throughout Peninsular Malaysia.

During the handover ceremony, Atsunori Murata, Chief Operating Officer of Isuzu Malaysia, extended his gratitude to representatives of Nippon Express Malaysia for their continuous support and trust in Isuzu commercial trucks. Murata believes that the Isuzu GIGA trucks procured will strongly contribute towards Nippon Express Malaysia providing consistently fast, efficient and cost-effective solutions that are optimised for various business needs.

To commemorate the special occasion, Murata took the opportunity to present an appreciation memento in the form of an Isuzu Miniature Truck and a Mock Key to Richard Gui, General Manager, and Hiromasa Moriya, Corporate Account Manager, of Nippon Express Malaysia.

The ceremony was also attended by Mohd Khairuddin B. Ramli, Assistant Manager of Nippon Express Malaysia's Transport Department, aside from Phang Jiu Leon, Sales Manager of Key Power Motor Sdn Bhd. 

**3 YEARS 500,000KM
MAINTENANCE FREE AXLE**



01 Easy To Set Up

1. Pre-assembling integrated wheel end for easy maintenance. Advance Composition for easy un-installation and installation of ensemble .
2. Nut installation by one-time tightening only .
3. Achieving easy wheel end installation .



02 Light In Weight

HJ Disc brake bearing accuracy reach P6 grade with higher supporting rigidity. As distance between bearing shortened, a smaller wheel hub achieves weight reduction up to 34%, from 29.48kg to 19.5kg .



03 High Load Bearing

HJ Axle adopt unique single piece axle beam design, with advanced craft technology. Using hot extrusion moulding of SAE1527 seamless tube, featuring with strong rigidity, high intensity, big torsion resistance and yield resistant. Fatigue test can reach 2 million under 2.5 times pressure of the rated capacity (far exceed 0.8 million times standard) .



04 Low Friction

New grease is compatible with all wheel end parts. It provides better lubrication and protection. Reducing friction by 30% as compared to regular lubricating grease .



05 Long Life

With added rare element of MO, Etc, can prevent crack and deformation .

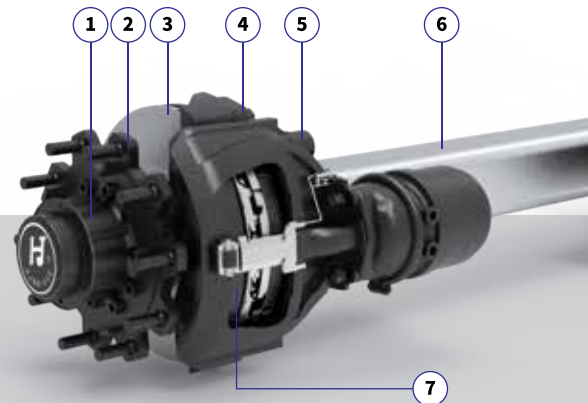

- 1 HJ Bearing
- 2 Wheel Hub
- 3 Special Alloy Disc Brake
- 4 European Caliper
- 5 Integrated Forging Brake Spider
- 6 Integrated High Intensity Alloy Axle Beam
- 7 Imported Brake Lining

Item No.	Max Capacity (Kgs)	Bearing	Axle Tube (mm)	Disc Brake Size (mm)	Center Distance Of Spring FM (mm)	Recommended Spring Width (mm)	Total Length (mm)
HJD10F08P10-1840-000	10000	F-583251	150x150/ Φ146	Φ430x45	900	≥ 90	2148
	Track (mm)	P.C.D (mm)	Wheel Stud n-M*1.5 Criterion	H (mm)	Recommended Wheel Rim	Recommended Tire (In)	Axle Weight (Kgs)
	1840	Φ 335	10 - M22x1.5	Φ280.8	11r22.5	22.5 "	335

Note: Water Cooling On Disc Brake Is Prohibited Optional Track Length Optional Air Suspension Lifting, ABS Gear Ring And Sensor

GUANGZHOU HUAJING MACHINE MANUFACTURE CO.,LTD

GUANGDONG HUAJING AUTO SPARE PARTS MUNUFACTURE CO.,LTD

TEL (Oversea Sales) : 0086-020-26216036
Email: huajing-1@hj-machine.com

FAX (International Sales): 020-26216092
Website: www.hj-machine.com

GZ Factory ADD: Yongan Road Zhaidong Xintang Town, Zengcheng Guangzhou Province, China(511356)

GD Factory ADD: By 106 National Way , Jingtou Industry Park, Jingtou Town, Fogang County, Guangdong Province, China



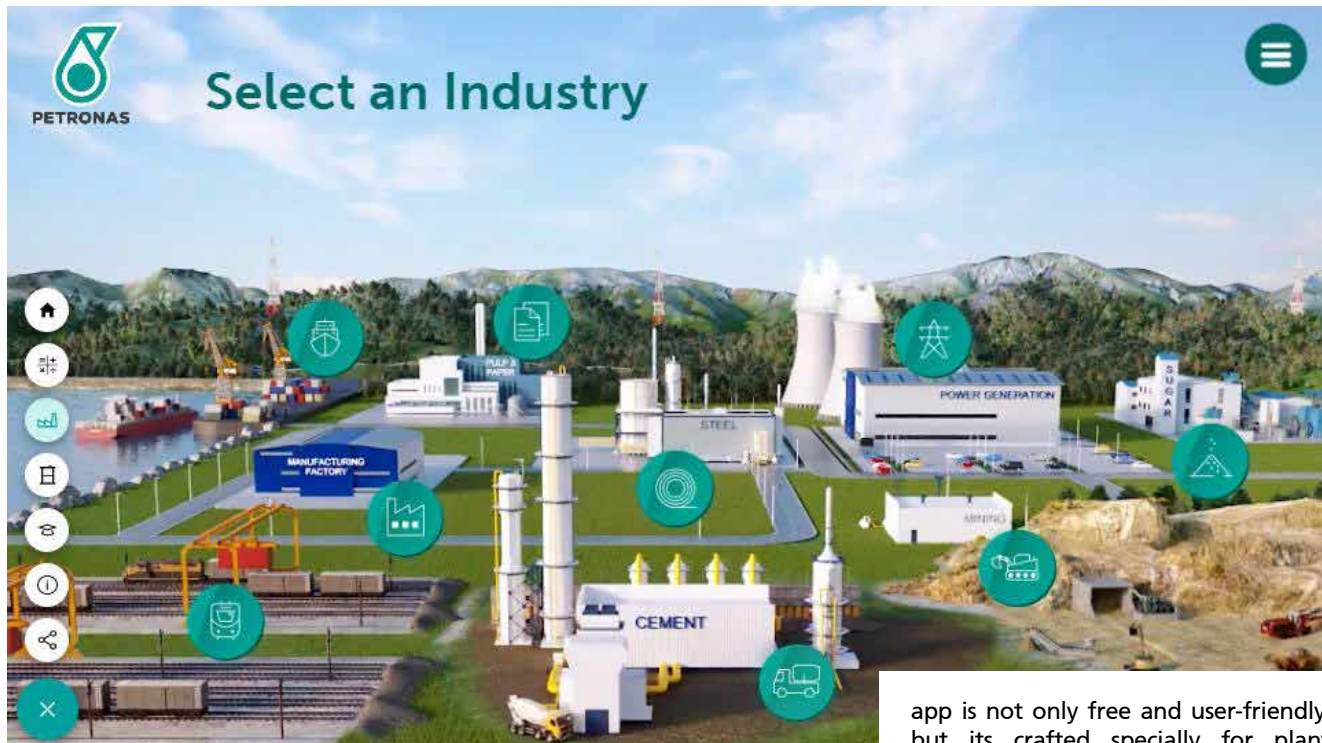

PETRONAS Launches PETRONAS Lubricants Toolbox

This free industrial learning app is now available for iOS and Android tablet users.

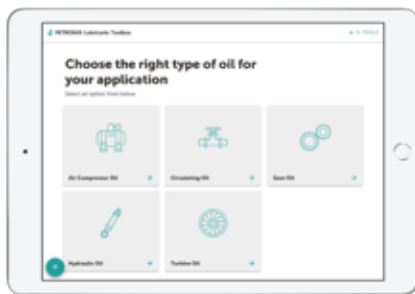
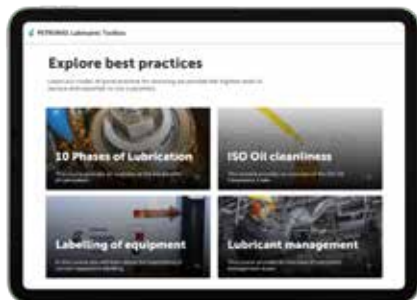

app is not only free and user-friendly, but its crafted specially for plant operators to optimize the total cost of ownership while reducing unforeseen downtimes through e-tools like the lubricant consumption analyser and more”, said PLI Global Distributor Marketing Lead, Silvano Berardo.

The lubricant consumption analyser e-tool available in the app is used to benchmark against industry standards and identify any deviations to help plant operators identify where they should focus improvement efforts to reduce consumption and costs in their business. The app also boasts an animated and interactive virtual tour of several industrial plants where PLI products are used.

The toolbox can be found here: www.pli-petronas.com/en/industrial-toolbox

PETRONAS Lubricants International (PLI), a wholly owned subsidiary of PETRONAS, today launched its first app, the PETRONAS Lubricants Toolbox, for iOS and Android tablet devices.

In PLI’s maiden venture to break through the digital app space, the user-friendly PETRONAS Lubricants Toolbox app demonstrates PLI as a Fluid Technology Partner capable of providing innovative solutions, going beyond primarily supplying lubricant fluids across the globe.

Available for free, the PETRONAS Lubricants Toolbox offers valuable information for those working in industrial sectors on the PLI range of lubricants such as product properties, technical data sheets, OEM performance levels, product performance hierarchies and associated benefits from trading-up and product comparisons. For user convenience, the app is available for use both online and offline.

“The PETRONAS Lubricants Toolbox is altering the way industry players research and compare PLI lubricants to suit their specific industrial plant needs. Our unique

About PETRONAS Lubricants International

PETRONAS Lubricants International (PLI) is the global lubricants manufacturing and marketing arm of PETRONAS, the national oil corporation of Malaysia. Established in 2008, PETRONAS Lubricants International manufactures and markets a full range of high-quality automotive and industrial lubricants products in over 90 markets globally. Headquartered in Kuala Lumpur, PLI has over 30 marketing offices in 27 countries, managed through regional offices in Kuala Lumpur, Turin, Belo Horizonte, Chicago and Durban. 

EXCLUSIVE RISK FREE OWNERSHIP

— LIMITED UNIT ONLY —



OWN AT 50% AFTER 2 YEARS

AVAILABLE MODELS

FOTON C2  PANEL VAN	MONTHLY PAYMENT FROM RM2,1XX INCLUDED FREE MAINTENANCE	JAC N45  3 TON	MONTHLY PAYMENT FROM RM2,XXX INCLUDED FREE MAINTENANCE	JAC N75  5 TON	MONTHLY PAYMENT FROM RM2,XXX INCLUDED FREE MAINTENANCE
---	--	--	--	--	--

PACKAGES INCLUDED

- 01 OPTION TO OWN AT HALF PRICE*
- 02 FREE* MAINTENANCE
- 03 FREE* ROADTAX
- 04 FREE* INSURANCE
- 05 ONLY 2 MONTHS DEPOSIT*
- 06 WEAR & TEAR ITEMS COVERED* (SELECTED ITEM)

WHAT ARE THE BENEFITS OF THIS PROGRAM?

- ✓ WORRY-FREE OWNERSHIP
- ✓ ZERO INFLATION
- ✓ ONE FIXED PAYMENT
- ✓ DEPOSIT LESSER THAN 10%
- ✓ MINIMAL ADMINISTRATIVE WORK
- ✓ MORE WORKING CAPITAL
- ✓ FLEXIBILITY AT THE END OF TERM
- ✓ FREE FROM VEHICLE DISPOSAL
- ✓ 100% ++ FINANCING
- ✓ RENTAL CONVERTIBLE TO DOWNPAYMENT
- ✓ TELEMATICS PROVIDED
- ✓ MINIMAL RISK

WHY CHOOSE EXCLUSIVE RISK FREE OWNERSHIP?

EXCLUSIVE RISK FREE OWNERSHIP

- ✓ Only 2 + 1 upfront
- ✓ Only 2 years commitment
- ✓ Hassle free for road tax, insurance and maintenance
- ✓ Low Monthly Payment

VS

HIRE PURCHASE

- ✓ Minimum 15% Downpayment
- ✓ Fixed Financial Commitment Up To 7 Years
- ✓ Yearly insurance, roadtax & maintenance at own cost
- ✓ Limited Warranty Period

T & C apply*



+6019 571 2345 ✉ info@mpiregroup.com.my 🌐 <https://mpiregroup.com.my/>

📍 No.2, Jalan 51/225A, Zon Perindustrian PJCT, Sek 51A, Petaling Jaya, Malaysia

MPIRE AUTO SDN BHD (HQ)



Supply Chain Hero

While much of the country's workforce moved to work from home, e-commerce business saw great, and rapid growth and demand in this period. Especially online purchases and delivery of food and other essential items topped the list of goods moved. Obviously, a reliable vehicle is important to ensure smooth and effortless delivery. In times like these, the reliability of the vehicle secures the income of the rider.

According to Fahmi, this was one of the finest hours for the Daihatsu Gran Max. "This vehicle remains as mode of transport means specially for last mile carrier services and it has been instrumental during the past weeks." The Gran Max Panel Van and Pick-up Box Van are especially fit for SME Delivery Partners, such as Ninja Van, Shopee, SkyNet as well as for other independent food deliveries.

The significance of the Gran Max for such businesses is evident and it is among major factors that influence the choice of vehicle for a transport company focused on courier work. Most delivery drivers are looking for a van that blends space, great mobility and low running cost. Gran Max particularly shines with its 'passenger car-like comfort' in which driver comfort is solid for a basic looking interior. Supplementing this is driver handling which is easy to use in terms of mobility, especially within urban areas. With a 1.5 Litre DVVT engine, the Gran Max produces the right amount of power and speed that

Gran Max Makes Grand Impression in Tough Times

Daihatsu's Gran Max proves to be a hero during the lockdown while the brand innovates vis-à-vis a drastically changed business environment.

Essential even in the most testing of times, transportation and logistics services were one of the industries that the Malaysian Government depended on in order to cope with the outbreak of the COVID-19 Pandemic.

The pandemic has certainly impacted many businesses in negative ways. However, some took the opportunity to sharpen their tools and to find ways to support Malaysians. We spoke with Muhammad Fahmi, Senior Manager Corporate Planning, Product and Marketing of Daihatsu Malaysia. He told us more about their insights gained in the past two months and efforts in refining Daihatsu's resources to further support the Malaysian economy.



enables it to carry huge loads while maintaining inexpensive running cost. Some consider it to be the best in its class.

With the shift from shopping in brick and mortar stores to online shopping, the Gran Max is best suited to cater to the increasing demand in courier transport with the increased volume of online purchasing. While some may say that this is a temporary phenomenon, whereby courier companies are benefiting from e-commerce delivery, Fahmi is of a different opinion "A group likely to benefit from COVID-19 in the long run is the e-commerce sector. In general, from an unprecedented spike in online orders and grocery deliveries, but going forward, more people may continue to shop online as they may find this more convenient, practical and safe."

Daihatsu Commitment During the Crisis

Committed to their customers, selected Daihatsu service centres, mobile service and emergency breakdown team have always been on standby to continuously serve its fleet customers. Elaborating on this, Fahmi said "Our dedicated Aftersales team was on standby to assist in reducing vehicle downtime and getting vehicle to be back up and running on the road as soon as possible. It is our responsibility to ensure logistics

partners are able to provide the best service to the customers and community without any obstacles." However, our clients did not have to worry much. The Daihatsu Gran Max is built with durability and reliability in mind, giving assurance that every final mile delivery arrives on time and in great condition. "There were no major breakdowns during the ongoing movement order and most of our service visits at the moment are only for regular interval service maintenance," he further added.

Options for the New Normal

Following the pandemic, Fahmi also expects the emergence of new businesses. Being able to cater up to 17 types of Gran Max body applications including the availability of automatic transmission for the panel van to fit every business need, he sees the possibility of a rise in independent and start-up businesses. There may also be a change of business for some or the inception of side businesses to generate additional income to counter economic downturn.

Through its official website (www.daihatsu.com.my), the brand recently introduced "Daihatsu e-Showroom" in an effort to create other avenues for customers to explore Daihatsu products and services from the safety and comfort of a remote location. "Admittedly, this may sound unorthodox and unconventional

for the commercial vehicle industry. However, we are seeing some positive responses from this while also being able to minimize certain manual sales and service processes." Meanwhile, Daihatsu is working constantly to further improve its services to fit the #newnormal and business landscape.

Resuming Business Operation

Daihatsu Malaysia, including its group of subsidiaries, has resumed business operation nationwide effective 12th May 2020. According to Fahmi, all staff is to comply strict standard operation procedures for the safety and well-being of its customers and employees.

Daihatsu takes responsibility in addressing COVID-19 concerns sternly by having its sales and service outlets to implement precautionary steps which are to remain in place for as long as the virus is prevalent.

Social distancing tags are placed at every vital point and all customers including employees are required to have their temperature checked with health declaration form filled before entering the premises. In addition, hand sanitizers and facemask will be provided while safety posters were put up at every outlet as a reminder of the required SOP guideline by MITI and MOH.

Every vehicle will be sanitized thoroughly before and after service. Daihatsu strongly encourage customers to make prior service appointment via phone and website to accommodate #socialdistancing practice.

Extending Responsibilities

MBM Resources Berhad – the parent company of Daihatsu Malaysia Sdn. Bhd. have made a RM 300 000 medical donation on March 27th to Kementerian Kesihatan Malaysia (KKM) in support the nation's healthcare system in the ongoing battle against the novel coronavirus COVID-19. Moving forward, the determination and togetherness showcased by all Malaysians in combating this crisis have ultimately inspire Daihatsu Malaysia to strive further to play its part in flattening the curve for and improving socio-economic for the country. 



Enhanced Sidelifter Ticks All the Boxes for Haulage Company with a Furnishing History

For many years the Ming Zhang Group has perfected the art of quality furniture manufacture. Its 'Venice' brand is synonymous with bedding products and mattresses designed to enhance the sleep experience, and sofas built for comfort and improved posture. The Bestari Jaya based family business has been successfully manufacturing and selling furniture on the global market for more than 20 years.

3PL Logistics (Third party Logistics) was added to the group's core operation about ten years ago. This bold diversification to the world of warehousing and transportation saw the company grow from strength to strength and employee numbers have grown massively from 50 to 250.

The Ming Zhang Group, led by director Dato Tan Wai Khan, wanted to keep ahead of the logistics game. They identified the benefits a sidelifter could bring to their haulage business and saw how this type of equipment could improve efficiencies. Ming Zhang Group was introduced to Steelbro with a referral from another organisation, who were impressed by the Steelbro product and its after sales service, led them to approach the New Zealand based company. Large capital equipment decisions are never made lightly, but the group finally decided to choose Steelbro and invested in two SB450 units. They were also able to take advantage of the latest generation of sidelifter unit with improved features.

Designers at Steelbro had recently made enhancements to the standard SB450 sidelifter to further improve the quality, performance and reliability of the unit. The SB450 model had already proved to be a popular choice in Malaysia for transport operators when conditions are extreme and call for a more rugged



sidelifter unit with a stronger lifting capacity. According to Steelbro, with the SB450, transfers of containers weighing up to 45 tonnes can be made easily within a safe working envelope.

The new sidelifter units tick a number of boxes for the Ming Zhang Group. According to the group, longevity of the frame, crane and trailer is important; units are robust and well-built and they expect them to have a long life. Being able to lift 45 tonnes is another advantage. Operators find



them easily manoeuvrable and can double stack containers easily and safely. Operators also expressed how impressed they were with the many safety features, efficient hydraulic system as well as the ability to lift 2 x 20' containers as an option.

The new units have proved invaluable for staging and shunting and for container rescue operations. The units are being used to transport tanktrailers as well as the standard 20' and 40' containers, and mainly for short haul journeys.

Enhanced features of the new generation models include aluminium mudguards and LED tail bar, additional safety features with LED emergency beacon light and LED rear licence lamp as well as 4 extra LED working lights for night operation.

Additional decals have also been added for safety on the road plus rear control box offering double protection for safety and theft.

The unit features the latest V2403 Kubota engine with higher HP and improved performance. The engine offers better mileage and less down time with OEM approved long life coolant and premium grade engine oil. It has been designed with a metal cover for radiator and fan offering extra protection.

Light weight durable lifting chains are included for heavy duty operation, there are smart leg sensor for safety and stability as well as proportional landing legs with reinforced support.

Steelbro work hard to ensure the life of the product long after the unit is sold. They ensure the reliability and lifetime of all Steelbro sidelifters with genuine parts and expert maintenance.

A range of genuine Steelbro spare parts are available for current Steelbro product lines. Damaged items are easily replaced and steel fabricated parts can be made to order.

Maintenance and repair work are expertly managed by the Steelbro team. They also offer repair and maintenance contracts (RNM) for all new and existing units.

Training certified operator training is delivered by Steelbro trainers for new sidelifter purchases as well as refresher training on request.

Steelbro offer a trade-in and refurbishment service to ensure the customer's fleet is always running at optimum efficiency.

Steelbro provides a nationwide network of workshop-based services plus 24/7 mobile support within the Central Region to support regular servicing and help ensure the cost-effective running of customer's sidelifter equipment.

Finally, to provide peace of mind, the Steelbro sidelifter is backed up by a 36-month warranty on crane structure. Steelbro components are sourced from internationally recognised manufacturers ensuring commitment to quality, availability and support worldwide. **F**

CAPAS

CHENGDU

CAPAS Defers to 2021

Following the Chinese Government's initiatives to prevent and control the COVID-19 outbreak, the organisers of the Chengdu International Trade Fair for Automotive Parts and Aftermarket Services (CAPAS) have announced the defer of the show's 2020 edition. The fair, originally scheduled from 21 to 23 May 2020, will now be held from 20 to 22 May 2021.

In China, the State Council issued an announcement on 6 April about the prevention and control measures that combat the spread of COVID-19. It emphasised the importance of curbing the epidemic while resuming business and production gradually. The notice also laid out a clear framework for public activities, advising that large-scale events should be suspended until further notice.

To actively implement the Government's instructions, and in steps to prioritise public health and safety, the organisers of CAPAS have decided to defer the upcoming edition of the exhibition. The event will now be held from 20 to 22 May 2021 at the Chengdu Century City New International Exhibition & Convention Center, China.

Mr James Yu, Deputy General Manager of Messe Frankfurt (Shanghai) Co Ltd, commented: "We are following the Chinese Government's guidelines to support the containment of the virus. Equally, the wellbeing of our fair participants, contractors and supporting parties is always our priority. It is a difficult but responsible decision to defer CAPAS to 2021. I look forward to seeing our industry friends next year where we can explore the dynamic growth of the Southwest China market together."

CAPAS is jointly organised by CCPIT-Auto, Messe Frankfurt (Shanghai) Co Ltd and CCPIT-Sichuan. For the past six editions, CAPAS has served as a leading platform for business, information exchange and investment in Southwest China's automotive industry.

Background information on the China Council for the Promotion of International Trade, Automotive Sub-Council (CCPIT-Auto)

The China Council for the Promotion of International Trade, Automotive Sub-Council (CCPITAuto) promotes foreign trade and economic cooperation, technical

exchange and introduction of advanced technologies for China's auto industry by following the China Council for the Promotion of International Trade and China Chamber of International Commerce charter. It acts as a bridge for Chinese auto industry enterprises to build cooperation and exchange opportunities across the world. In addition, the committee organises three world leading and highly regarded international automotive exhibitions in Beijing, Shanghai and Guangzhou.

Background information on Messe Frankfurt

Messe Frankfurt is the world's largest trade fair, congress and event organiser with its own exhibition grounds. With more than 2 600** employees at 30 locations, the company generates annual sales of around EUR 733** million. We have close ties with our industry sectors and serve our customers' business interests efficiently within the framework of our Fairs & Events, Locations and Services business fields. One of the Group's key USPs is its closely knit global sales network, which extends throughout the world. Our comprehensive range of services – both onsite and online – ensures that customers worldwide enjoy consistently high quality and flexibility when planning, organising and running their events. The wide range of services includes renting exhibition grounds, trade fair construction and marketing, personnel and food services. Headquartered in Frankfurt am Main, the company is owned by the City of Frankfurt (60 percent) and the State of Hessen (40 percent). * preliminary figures 2019

Background information on the China Council for the Promotion of International Trade, Sichuan Council (CCPIT-Sichuan)

The China Council for the Promotion of International Trade, Sichuan Council (CCPIT-Sichuan) aims to promote foreign trade cooperation and communication, under the guidance of the Sichuan Provincial Party Committee and the Provincial People's Government, and in accordance with the guidelines of national economic policy and principles. Its main duties are to encourage foreign trade and investment, enhance economic and technological exchange and cooperation, and to foster local enterprises to participate in the economic globalisation. CCPIT-Sichuan also organises a number of international exhibitions including the Western China International Fair. 



YOUR CHOICE ON
Cost Efficiency
Eco- Friendly
Re- Con Parts



SAVE UP TO
70% COST
EFFICIENCY



**WELL-
EQUIPPED
MACHINE
TEST**

**SPECIALIZE IN RE- CONDITION PARTS
WITH WARRANTY GUARANTEED**



TURBO PERFORMANCE SDN BHD

Solution for New & Remanufactured Turbocharges

199901004453 (479353-V)

TEL: +603- 6187 7097 | FAX: +603- 6187 7150 | EMAIL: TP@YONMING.COM

No.8, Jalan Industri Batu Caves 1/6, Taman Perindustrian Batu Caves,
68100 Batu Caves, Selangor Darul Ehsan, Malaysia.



**OPERATE WITH ADEQUATE SAFETY PROCEDURES IN PLACE
FOR YOUR HEALTH & SAFETY.**



own equipment but such homemade equipment is usually heavy and not well thought out. Besides being unsafe equipments, those self-made equipments can never achieve the precision that the JOSAM frame press system can; measuring frames down to a millimetre. JOSAM products are also certified according to ISO 9001.

Properly aligned wheels improve performance and longevity of tyres. Wheels often become misaligned by hitting potholes, bumps, driving on uneven surfaces and through general wear and tear. It is therefore essential to maintain accurate alignment of the wheels, to ensure their quality and performance remains optimal. Maintaining proper wheel alignment is essential to avoid unnecessary wear on your tyres, steering, suspension and brakes which leads to lower operating costs in the long run. Accurate wheel alignment optimises

JOSAM Aligns Precision with Efficiency

JOSAM, together with their Indonesian partner Himawan Putra took part in the exhibition hosted by one of the largest automotive association in Indonesia.

Representing JOSAM at GICOMVEC 2020 from 5-8 March was Rickard Per Eriksson, Product Trainer at Car-O-Liner (Thailand)., Co Ltd. During a two hour seminar at the show, Rickard gave a presentation on the JOSAM frame press and wheel alignment systems. Headquartered in Sweden, JOSAM is part of the Car-O-Liner Group owned by Snap-On with a regional head-office and Training Academy in Bangkok, Thailand.

On why their frame press and wheel alignment systems are better than conventional methods or other systems in the market, Rickard shared that many workshops in Indonesia and most around the region tend to make their

Increased safety creating cost savings

SC3OCT covers every aspect of tyre management, delivering tailor-made solutions within the framework of internationally-defined standards on technical, practical and information support, including ISO and SIRIM certification, while understanding the stresses of local fleet operation.

SC3OCT delivers improved fleet performance by taking a sophisticated approach, however, simplifying tasks and creating adherence to proper ways-of-working for your operational staff.

- Competitiveness (operation efficiency)
- Cost effectiveness
- Control



SC3OCT™
Safety On Commercial Tyres

Consultancy / Know-how / Certified / ISO
SIRIM / Independent / Discipline / Traceable
Enhancement / Innovation



Talk to us:

Kit Loong Commercial
Tyre Group

+603 5122 2418

+603 5121 2417

talktous@kitloongholdings.com



driving stability, maximises tyre lifetime and improves vehicle's overall handling performance. According to Richard, two-thirds of all trucks and trailers on the roads of Europe are misaligned. Warning signs that it is time to get the wheel alignment checked include uneven thread wear, off-centre steering wheel when driving straight and vehicle pulling off to left or right.

As a product trainer, Rickard educates his customers on the products to ensure they are used correctly to produce the best results. The training usually takes one to two weeks to complete. At the training, Rickard focuses on three aspects namely theoretical training, production training and method training. Emphasis is placed on reparation methods, safety training and the use of proper equipment. According to Rickard, JOSAM equipments are extremely easy to use. During the training, he makes sure his customers understand how JOSAM equipments work as well as the usage of extensions. "We also train the customers on how to repair deformations. For instance, some deformations work with a specific type of reparation technique, so we will teach the customers our tips and tricks to ensure most efficient repair works are done," he shared. Although the training usually takes two weeks, Rickard said that the equipments are so easy to get used to that most customers complete the training in one week.

After the two hour seminar at GIICOMVEC, JOSAM had the opportunity to talk to Tanojo, owner of Sinar Surya, one of their Indonesian frame press customer. Tanojo runs a truck chassis repair shop in Karawang, West Jawa. Before using JOSAM equipment, Tanojo's workshop used conventional tools such as railroad tracks, jacks, chains and

hammers. To repair the chassis, technicians do it manually in non-standard ways, such as pulling a bent chassis with a car and so on.

"Besides taking a longer time, jobs like this are extremely unsafe. Our mechanics are less productive. Before using modern equipment, we could only work four to five units, but now are able to repair 40 to 50 units of chassis per month; our productivity has improved by leaps and bounds. Workshop revenue has also increased significantly since we switched to using JOSAM tools, due to the quality of repairs. We are now able to give insurance companies a three-month warranty for our repair works," said Tanojo.

Kevinski Himawan, Vice President of Himawan Putra Corp was also present at GIICOMVEC as a distributor of JOSAM in Indonesia. According to Himawan, the business opportunity for domestic truck chassis repair services is very promising, in line with the growth in commercial vehicle sales. "In 2017 and 2018, the commercial vehicle market grew 18 percent, while passenger vehicles only rose 4 percent. The commercial vehicle market in Indonesia is far ahead than passenger vehicles. With the growth of the commercial vehicle market, the demand for commercial vehicle repair tools will increase proportionately looking at the commercial vehicle population that continues to increase every year" he said. Himawan added that truck chassis repair services are needed by trucking businesses and are deemed very profitable for workshop entrepreneurs. "This opportunity exists because of the frequent chassis damage in Indonesia, the growth of trucking industry, and the unawareness that there is a modern and easier way," he concluded. **F**



Fifth Wheel Coupler

King Pin

Landing Gear



ALL KIND OF WINDSCREEN FOR TRUCKS & CARS



Hydraulic Tipping Hoists

Edbro
 Leading the market with product developments ever since 1916
 Member of **JOST**-World



HYDRAULIC PUMP



Iso Gear Pump

Bend-Axis Pump

Buffalo Mobile Batching Plant Uses JOST Landing Gear & TTK Trailer Component



U-LI AUTO PARTS & SERVICE SDN.BHD

(350857-M)

NO. 54, JALAN BESI, BATU 3 1/2, OFF JALAN SUNGAI BESI, 57100 KUALA LUMPUR. W. MALAYSIA.

TEL: 603-7980 8429 / 7980 8430 / 7980 8431 / 7984 3428 / 7983 8428 FAX: 603-7980 8433 E-MAIL: uliauto@gmail.com



SUPER TRUCK

AND LAUNCHING

(Thursday)

To Build a Mpire

Not all automotive segments are the same, as Dato' Billy Goh discovered when he started his commercial vehicle branch under Mpire. In this exclusive interview he talks about past and future of his ambitions for the transport industry.



Looking Abroad and Ahead

While bikes in Malaysia can carry smaller parcels or food, they are not suited to deliver bigger consignment or to make milk runs to drop off several shipments along a route. "Seeing the Foton trucks, I thought these are perfect." Coupled with the JAC light commercial vehicles, Mpire group now has the entire supply chain covered. "What I have learned is that the buying cycle for commercial vehicles is longer, compared to passenger cars. However, the business is not as competitive as the consumer side of the automotive business." Another insight he had was that the production facilities of Chinese CV brands are top notch and very advanced. One will notice that Mpire group is not selling buses. This harks back to the idea that the group is to cover goods transportation as opposed to people.

Founded in 2002, the Group today is a fast growing Automotive Group in Malaysia. Mpire Group Businesses covers Passenger Cars (Largest Hyundai Dealership Group in Malaysia), (Proton Dealership) and (Distribution of FOTON Pick-Up and Vans), Light Commercial (Exclusive Distribution of JAC Brand in Malaysia), Heavy Commercial (Distributor of FotonDaimler, a JV Brand of FOTON and Daimler), Car rental, Credit Lending and venturing into Car Assembly business. In our discussion with Dato' Goh we focus on the commercial vehicle side of his business.

Add-On

The Mpire Group started out in passenger cars. "My first encounter with the world of commercial vehicles was in 2017, when we successfully negotiated a deal with Cherry Automobile. They had a last batch of 470 vehicles in Malaysia, finding it hard to dispose of them." Having run into trouble, the brand was to look for ways to divest these vehicles. Goh approached them in order to explore the distribution rights, however in the end, the agreement concluded with Goh being able to buy out the 470 vehicles to be sold through his own network. "Of those vehicles we purchased, around 50 percent were commercial vehicles, the balance were MPV." Giving it a try, Goh discovered that the vans are selling well and within six months, his newly acquired stock sold out. Admitting that the group had no experience with this kind of vehicle, the management was surprised that the 12 seater van sold out the fastest.

Having exploited this opportunity, Goh went on to also prance on the last batch of Hyundai Inokom 1-tonne trucks in Malaysia. The particular model was no longer to be sold into Malaysia by the Koreans and he snapped up the remaining 209 units available here. "Again, these vehicles sold very well." At this time, Goh strategized to expand the business. Looking east, he found his answer in Chinese brands. Weighing various considerations, Goh concluded that western brands offer very little growth opportunities, while Chinese makes are improving and winning market shares. Goh also monitored the markets in developed countries. He realised that passenger cars will lose their attraction as younger people may not want to own their cars, but rather rely on ride sharing. At the same time, China showed strong growth in the e-commerce business and with that an increased demand for commercial vehicles. "Naturally, it would only be a matter of time before these two trends also take effect in Malaysia." Re-assured that his prediction was right, he is proud to report that there have been a MoUs signed for the purchase of fleets by a significant customer in the area of transportation for e-commerce.

Goh was affirmed in his decision to take on the JAC brand following a visit to China. What he found was the production was a highly effective and modern one, while on a personal level, the players just clicked. Sharing the same vision, the brand was offering the exclusive distribution of the light commercial vehicles in Malaysia, an opportunity that was too good to pass on for him.

Same, but Very Different

Having been active in passenger cars, Mpire group was able to apply some of their expertise to the newly formed segment in order to jump-start the business of selling commercial vehicles. From experience, Mpire group knows that customers are very particular about the delivery of their vehicle. "A buyer of a new car will be very detailed when it comes to the specifications of the vehicle, while ensuring that the hand-over is done right. This is because the buyer is also the user." However, for commercial vehicles, the situation is different as the person picking up the vehicle or driving it are not the buyers. "Most times it is not the purchaser or even the fleet manager to receive the vehicle." Acknowledging that the person collecting the vehicle may not be the buyer, but having tremendous impact on the brand reputation, Mpire group has instilled the same service level for collections of commercial vehicles as they would have in the passenger car side.

Another important issue is the after-sales service according to Goh. "One thing we have to be aware of is the fact that Chinese brands do not have a very good perception when it comes to the after sales service and we need to work very hard to counter that." As some Chinese brands may have a tainted image, it is even more of an uphill battle and the Mpire Group is putting an extra emphasis on this part of the operation.

Insights

Fundamentally different however is the decision making when it comes to buying cars versus buying trucks. Goh noticed that cars are bought with a lot of emotion attached to the selection and buying, whereas for trucks, it is a rational process. "Customers buying a truck know exactly what they want and need." As a result, the closing of a deal is much easier for commercial vehicles once one understands the need of a truck customer. According to him, once a customer has made a decision to buy a specific truck or truck brand, there is no ad or friend that may swing the decision. He also noted that brand loyalty is much more prominent in the commercial vehicle sector. "Once you have sold a vehicle to a customer, the company is likely to come back when it comes to expansion or replacement of trucks. If they are happy with you." Goh acknowledges that the group is a newcomer to the (commercial vehicle) industry, however, he is confident that he understands what customers are looking for.

As such, his recipe for success was to not focus on sales immediately, but to ensure that the after sales service is done right. Appointing over a dozen independent dealers, any customer can rest assured that the trucks can be serviced and kept on the road with a high uptime. Goh explained that the focus of the first year of operations was to ensure that the service network is in place, rather than aggressively selling vehicles. "This was certainly not an easy task, but through perseverance and foresight, we managed to put our two brands successfully into the market." In his view, it all comes down to understanding the needs of customers.

Fast-tracked Growth

When entering the market, Mpire Group decided to appoint dealer to fast-track the growth of the network. The appointed dealers and workshops were carefully chosen in order to allow each of them to handle sufficient volume in order to generate revenue. While Goh agrees that one may not be able to ensure 100 percent identical service throughout, but the benefit of having a larger network outweighed this. Supporting the network are mobile service teams that will come to the help of dealers and customers. "Rome was not build on one day. As such, we will continue to add dealers and workshops, with the east coast being a focus for this year."

Giving Meaning and Vision

Having a vision is important when guiding an organisation towards a goal. With the signing of two

brands as distributor, the company adopted the motto of "The fastest growing automotive group in Malaysia." This was to explain internally and externally what was happening and to solidify the efforts of the staff working for the group. However, having completed the stages of signing on brands to distribute and to build the service network, Goh is now changing direction for this year.

Approaching it Differently

Equipped with the right type of products to address the expected shift in market demand, Mpire group needed to shout about their new offerings. To break through the clutter, an innovative and more daring



marketing concept was chosen. For instance, the company offered a four-year, unlimited mileage warranty as one of the first in the market. The next deal to be had was a guaranteed buy-back program for the first batches of buyers. "What some people may do is to verbally offer the buy back. However, for us, it is all officially documented and agreed in contracts." These are just a few of the initiatives Mpire has taken in the past.

Looking at the developing situation at the beginning of the year, Goh and his team strategized another campaign. Realising that cash flow will be an issue for many transporters, although they may operate at a heavily reduced rate, a new offering is to address this. "Financing commercial vehicles is always an issue and currently, nobody can really say how things will develop." To support customers, Mpire Group will offer to rent out the trucks without commitment. Only after 24 months, the user of the vehicle will have to make a decision to either return the truck, continue renting or to buy it at 50 percent of the initial value. Taking away the worries, for the first 24 months, fleet operators would not have to worry about insurance and maintenance. Although Mpire Group is putting a substantial amount of money into the backing of this program, it will be accessible to selected customers after evaluation.

This is where the new guiding principle comes in. As of now, Mpire Group will position itself as a total solutions provider for the commercial vehicle industry. Not just offering the products, Mpire Group is also able to offer financing and more intricate offerings as the aforementioned rental program. Assuring customers about the future, Goh confirms that his products will be ready to meet the expectations and needs of the market. Requirements for both, B20 Biodiesel and Euro V emission norms implementations, are covered by the makers of the trucks in his stable. **F**





How to make a High-performing Semi-Trailer

Armor Lite is a Missouri based semi-trailer manufacturer with a home market covering the Midwest and Texas. The company was started in 2012 by Wesley Graviett, Tom Seyer and Jim Pharris. They all have extensive industry knowledge from the trailer industry and set high goals for the business: making the industry's best trailers and to always exceed the customer's expectations.

The company is experiencing healthy growth, so it looks like it's on the right track. What's the secret?

"We're always eager to explore new materials and production techniques that will give our customers more value for their money. We are focused on high-end trailers for the toughest jobs and choose materials to match. One example is that we upgraded our half-round semi-trailers from Hardox 450 wear-resistant steel to the new Hardox 500 Tuf grade," says Jim Pharris, Senior Partner at Armor Lite.



Armor Lite makes its half-round dump trailers in the new Hardox 500 Tuf wear steel.

How did the customers react to the change?

"I would say we have carved out a reputation for making trailers that stand up to the toughest jobs. Of course, we needed to confirm the steel's performance in real life before going all in. When the new grade became available two years ago, we started by making two similar half-rounds, one with Hardox 450 and the other with Hardox 500 Tuf which is a harder material that still has a high toughness. They were used by a local company for about a year in really rough conditions and the outcome was positive. The customer was happy and we were confident that this was the



Hardox 500 Tuf hasn't given Armor Lite any challenges in the workshop.

future. Today, we have made 30 half-rounds in Hardox 500 Tuf. Just by looking at them we can see that they stay in better shape, with much less denting even after transporting large stones and big chunks of concrete," says Pharris.

Upgrading made simple

Armor Lite has not come across any technical obstacles in the workshop when processing Hardox 500 Tuf. Welding works in the same way as for Hardox 450, no preheating is needed to get high-quality welds. Bending the plates into the half-round shape required a change in rolling parameters since Hardox 500 Tuf is a stronger material with higher springback. Once this was sorted out, production runs smoothly. Hardox wear plate is a very stable material and this is confirmed by the repeatable performance Armor Lite experiences in the workshop.

What's the future look like?

"So far, we make half-round dump trailers in both Hardox 450 and Hardox 500 Tuf with the same thickness. This naturally adds service life to the ones with Hardox 500 Tuf. We are looking into going down in thickness on Hardox 500 Tuf to save weight. This would be interesting for many customers since it allows for more payload without exceeding the total vehicle weight," says Jim Pharris.

Why the half-round makes a difference

In many ways, a half-round dump trailer is the optimum design when handling rocks and other large and heavy objects. Compared to a traditional box shaped dumper, the half-round structure actually becomes stronger from the lack of external reinforcing beams. The large free steel surface with a top rail allows the steel to flex when hit by a rock.

The impact forces are distributed over the plate, resisting dents and cracking. Fewer dents means less wear for a longer service life of the trailer – with the added bonus of giving a higher resale value.

A design without stiffeners is lighter and gives the opportunity for higher payload. The amount of welding is also drastically reduced, saving time in the workshop and cost for welding consumables.

The half-round body improves road handling since the load is automatically centered on the trailer even if it is loaded over the side. Another advantage is that the shape makes for faster discharge of the load.

WearCalc calculates the service life

SSAB, the manufacturer of Hardox wear steel, has developed an app called WearCalc. Armor Lite uses the app to quickly show customers how the wear

service life increases when using a harder abrasion-resistant steel. WearCalc is available from Apple and Android app stores for free.



When hardness meets toughness

SSAB is steadily pushing the envelope of steel production with its range of Hardox- wear steel. The latest grade – Hardox 500 Tuf – has a unique mix of hardness and toughness. Compared to a traditional abrasion-resistant steel, Hardox 500 Tuf can also work as a structural steel. This offers new opportunities to reduce or exclude supporting structures, allowing Hardox 500 Tuf to take the load instead.

When upgrading to Hardox 500 Tuf, manufacturers can choose to increase wear life or increase payload – or both. Using a thinner plate in Hardox 500 Tuf can easily give 10-15 percent greater load capacity for a dumper or container. Staying with the same thickness on the other hand can give a 30 percent longer service life or more, depending on the abrasive material.

"We had great expectations of Hardox 500 Tuf. It combined the hardness of Hardox 500 with the toughness of our worldwide bestseller Hardox 450. I'm sure Hardox 500 Tuf will be the new standard for premium heavy-duty tipper bodies, containers and buckets," says Jenny Brandberg Hurtig, Product Manager for Hardox wear plate. **F**

ASIAN TRUCKER DRIVERS CLUB

UPDATE



PREMIUM SPONSOR:



NITTSU





Trucking Community Comes Together to Help Drivers

Joining hands to support the industry during the time of the MCO, Shell Rimula sponsored face masks which were handed out to truckers through a mini distribution network we helped set up.

Having spoken to several transport companies, we got to know that they faced shortages of facemasks for their staff. When Shell Rimula's brand manager called to see if we could assist in the distribution of face masks, it was just the right moment to step up to the plate and do our part for the truckers out there.

With tightened Movement Control Orders in place, the delivery and subsequent distribution of these masks was not as easy as it would have been any other day. What we wanted to achieve is to get the masks to as many drivers from different transport companies as possible, without favouring any transporter for size or segment. Hence, we turned to truck OEMs in Port Klang as their workshops were still operational and Northport.

Scania, Volvo, Hap Seng Trucks, MAN and Northport were the distribution locations. NITTSU Transport arranged the delivery of the masks to these spots and we would like to thank all the participating parties for their support during this activity. **T**





of her father that Siti first developed an interest in driving—when she was practicing for her driver's license test, her father was always by her side to teach her the ropes of navigating a car. Siti even proudly recounted to Asian Trucker the time she was the one chosen by her father to drive him to the hospital after his leg got bitten by a tiger in their hometown at FELDA Jenderak Utara, Pahang! She expanded on how she was one of the three girls among her siblings and laughed, adding that she was always “one of the boys’ in the family.”

It was not until three years ago when one of her trucker brothers told her about a career opportunity with Kontena Nasional Berhad (KNB), the country's premier logistics company with 46 years of experience in logistics operations. KNB was specifically looking for female drivers to hire, and Siti immediately jumped at the chance. Having left her previous job as a cashier at a Petronas gas station, Siti was excited to take on this new path in her life. Sure enough, Siti scored the job position and went on to spend two and a half years at KNB, having driven the likes of Scania, Mercedes, and Volvo.

At her current position at Sentiasa Hebat Sdn Bhd, a leading logistics company with expertise in Container Haulage solutions, Siti has taken all that she had learned at KNB and put that expertise to good use. At her current employment, Siti has been tasked to transport essential produce and goods, such as onions. Her day-long trips alternate between Port Klang and Seberang Perai, Penang, and Port Klang and Padang Besar, Perlis. Siti's daily itinerary usually starts out at night as she is normally required to reach her destination by the early morning.

Once at her destination, either one of two things will happen: she will take the time to sleep, or take the time to eat. Siti posits that a sound mind and a full stomach are paramount in ensuring a safe journey back to the headquarters located in Bandar Sultan Suleiman, Port Klang. Siti also revels in the fact that she lives very close to her job in nearby Port Klang, where she currently resides with one of her elder brothers (also a trucker).

The Road to Happiness is Paved with Passion

Trucking had always piqued her interest since the tender age of 13, and now she has finally fulfilled her dream of being the captain of her own truck. Siti Noraini Layly binti Muhamad Hanapiah tells Asian Trucker her story.

Siti had always looked up to her brothers and father who were well experienced in the trucking industry. The fifth child of nine siblings, Siti had three elder brothers who drove container trucks, and a father who was well versed with a lori kampung. Siti told Asian Trucker that she had always had a liking to trucking but was lacking in execution—many companies at the time were not offering job opportunities for women.

Despite the lack of available trucking positions, Siti was always encouraged by her father and brothers to never give up on her passion. Growing up, she liked to be challenged and always took up every chance she could get in participating in co-curricular activities in high school. In fact, it was because

Siti told us that her current trips have been made much more comfortable by her current ship—a prime mover from the DAF XF range. It was love at first drive; Siti claims that this vehicle is her favourite so far due to the high sleeper cab, but ultimately joked about how the DAF XF truck appealed to her because of how it made her seem bigger and taller than everyone else on land!

Now, even in the month of Ramadan, Siti has chosen to be on the road everyday (even with the option of day offs) and is enjoying the simple joys that she encounters on her daily drives. Nothing gets in the way of Siti's pursuit of enjoyment in life; she finds ways to entertain herself on the road, such as by singing along to famous karaoke songs with the windows down. As long as she has her favourite Malaysian singer, Ella, accompany her for the journeys ahead, quite possibly nothing can bring her down. "It doesn't matter if my voice doesn't sound good, as long as I am feeling good!"

With an insatiable appetite to travel and see new things, Siti also told Asian Trucker that she enjoys taking different routes when the opportunity arises, even though her trips only alternate between two destinations. Our Trucker of the Month mentioned that her favourite alternate routes are the ones that go through the inner roads of villages, allowing her the chance to observe the cultures and lifestyles of the locals. Siti hopes that, by toiling hard every day, she will have the chance to one day drive herself to Langkawi, her ultimate dream destination, for some fun and relaxation.

"If we're happy, we can make other people happy as well." Siti's outlook on life is one full of zeal and zest; her positivity is translated into her work ethic and behavior, and it truly shows. 





MAN Launches The Best MAN Ever



New features, new design, millions of hours of work by staff and input from professional drivers has resulted in the outstanding new MAN family of trucks.

MAN Truck & Bus, after five years of intensive work and for the first time in 20 years, has presented to the world in the Spanish port city of Bilbao a new generation of MAN trucks. The new generation is the result of a total of twelve million hours of passionate work by the 2 100 people directly involved in the project – and the pride of more than 36 000 dedicated MAN employees worldwide. The launch of the new truck has a big hit. From the beginning MAN has involved drivers and customers in the development of the new generation, so their requirements could be embedded in the new vehicle.

Transformational Trucks

When welcoming his international guests at Bilbao port's Event Dome, Joachim Drees, CEO of MAN Truck & Bus SE, left no doubt that they could expect a very special evening: "Our new MAN truck generation represents

the transformation of the entire company. Toward a company that is completely focused on the customer and their needs."

The introduction of this newly developed truck generation was completely oriented towards the changing requirements of the transportation industry and sets new standards for – among other things – assistance systems, driver orientation and digital networking. The new truck generation thus represents the development of MAN Truck & Bus from vehicle manufacturer to a provider of intelligent and sustainable transport solutions.

Sustainable Solutions

Andreas Renschler, CEO of TRATON SE, who also warmly welcomed the guests in Bilbao noted: "We at TRATON Group will change the transport sector. By providing our customers with precisely the solutions they need to remain competitive and sustainable as the sector changes."

And the sector is changing with new vehicles being built to reduce their impact on climate change, being built to be the safest ever, and designed for the modern driver as the new truck is not only office, but home. The new Generation, following in the tread prints of its predecessors,



brings a new level of comfort, safety, efficiency, reliability, service as well as connectivity and digitalisation.

With fuel savings of up to 8 percent, the new MAN Truck Generation achieves significant reductions in CO2. The newly developed turn assist helps prevent serious accidents in urban traffic – four years before the legally prescribed introduction. The lane change assistant warns the driver of adjacent vehicles.

Simplifying Business

Today, the requirements in all areas of the transportation industry are more diverse and complex than ever – forecasts for the future indicate that fundamental transformation of the industry is in ‘full gear’. This brings great challenges with it – the transport volume in the EU alone is forecast to increase by 40 percent in the next 20 years. At the same time, strict legal regulations are intended to reduce CO2 emissions by 15 percent by 2025 (with an additional reduction of 30 percent by 2030). To intensify the challenges is the growing shortage of drivers, not just in Asian, but worldwide.

The increasingly comprehensive digitalisation across all logistics processes sets a fast pace for transport companies and they look to OEMs for solutions. “Our customers expect us



Test drive in the simulator Manuel Eichleiter testing operability of the new cockpit on a virtual tour.

to provide them with answers to these questions, and rightly so,” Joachim Drees points out. “For their sake, we need to be one step ahead of these changes with all their direct and indirect effects. This is a huge, but at the same time, extremely exciting task – it means that we need to think in different, new dimensions as the manufacturer of our products. We do this with our new truck generation.”

Four Core Topics

This approach is why the new MAN truck generation offers everything customers and drivers have always valued and expected from their MAN vehicles – but even better. It unites tried-and-true virtues with absolutely future-oriented developments designed to take the burden off freight forwarders and drivers and make their daily work easier, despite increasingly complex conditions. In doing so, MAN focusses on four core topics: the driver in their workplace, the vehicle’s efficiency and its reliable usability, as well as the strong and competent partnership for customers.

In order to optimise the truck as workplace and adjust it to best meet the requirements of the driver, their performance and motivation need to be placed at the forefront. After all, the decisive building blocks for a transport company’s economic success are the commitment and satisfaction of drivers. This is why the new MAN truck generation sets standards in terms of user-friendliness, optimum ergonomics, operation which is more intuitive and reliable, networking with digital devices and applications and, last but not least, optimum space, a well-thought-out storage concept and perfect sleeping comfort – all this geared towards needs which were determined based on experience.

Reducing Driver Strain

MAN consistently included the expertise and feedback of drivers and business people throughout the entire development process. Modern assistance systems such as the newly developed turn assist, the traffic jam assistant as well as lane change assist reduce the strain on the driver and ensure increased safety in road traffic.

Perfectly formed and functional like never before: the new TG features a dynamic exterior design with highlights such as LED headlights and the new radiator grille. Holger Koos and Rudolf Kupitza have developed a design for the truck that combines progress and tradition. So, a true MAN.

Colour Me MAN

Golden topaz, phantom blue and anthracite grey: these three colours were used for the new series for its market launch. The MAN designers are sending out clear messages with the choice of colours: “The gold paintwork stands for value and tradition. It signals that the truck can withstand the highest demands regarding reliability and value retention,” explains Holger Koos, head of vehicle design at MAN. The blue paintwork also evokes positive

associations, symbolising sustainability and future viability. The designer is thinking in particular about the future range of alternative drives for MAN trucks. The message of anthracite grey, in turn, is obvious: grey like a rock, durable and indestructible. This colour signature is especially intended for the new TGS as a construction site vehicle in heavy terrain.

Retaining Value

Value retention is not only reflected in the colour selection, it is a guiding principle that shapes the entire design. "Our customers want the new truck to be immediately recognisable as a MAN," says Rudolf Kupitza, head of truck design. The design team has taken a cautious approach to the truck's exterior design, not wanting the predecessor generation to appear outdated compared to the successor. This resulted in the new TG being externally geared toward family similarity with the existing vehicle portfolio. The new truck's designers are nevertheless clearly showing indications of progress and the future. "We have further developed the strengths of the MAN truck through its design," says Kupitza. "The new vehicle arouses more emotions, yet at the same time it has improved functionality."

The redesigned front end creates an intense emotional expression. "We have elaborated even more of the lion's face on the MAN truck," Kupitza points out. Beneath the striking chrome moulding with the lion logo, the black radiator grille forms the lion's mouth. This creates an even more powerful appearance, since the black trim continues to the bumper area.

Ready to Pounce

"The dynamically shaped structure of the bumper simultaneously reminds us of a feline predator that is ready to pounce," says chief designer Holger Koos, describing the vehicle's appearance. "Viewers may not be aware of these features, but they feel the impression of animalistic force and dynamism in the new TG."

The new LED headlights help make the new truck the Lion King. Their curved shape suggests the fierce eyes of the predator. "Although we have taken care not to make the truck too aggressive," says designer Kupitza. "A MAN truck is a sympathetic road user."



The Vario passenger seat in the new MAN TG series can be turned inwards

Design Dynamics

The increased design dynamics continue on the side of the cab. The projections behind the side window (internally referred to as 'aerodomes') are more obviously presented as a visual brand element for MAN trucks. Their number has been reduced from five to three to make the lines more prominent. The contour has become sharper. Sharp like a lion's claws.

The side windows, wind deflectors, door handles and door handle beading were also given dynamism in their design. The expression of muscular agility in design is not merely an optical plaything, it gains in terms of aerodynamics resulting in a positive effect on fuel consumption. The shape and position of the mirrors has been slightly changed, with the effect that the driver now has a wider field of view.

Loving Design

The designers have expended a lot of loving work on the lateral indicator units: these are chrome-plated and have the MAN logo on them. "Such subtleties emphasise the high quality of the vehicle and generate emotions," says Rudolf Kupitza. The MAN designers' conclusion: the new TG looks modern, but not over-styled. It embodies precision, quality, value retention and reliability. These are strengths that are significant in the transport business.

The driver's workplace has been subjected to a revolution. The cab and cockpit have been completely redesigned. The focus was on ease of operation, ergonomics and high living comfort. Ten years of research and development with 742 test users made the perfect cab possible.

Remarkably, often it is small things that make for big changes. For example, the three-finger-wide switch right next to the steering wheel. This is the new electric parking brake, which used to be a pneumatic lever located in its own centre console next to the driver's seat. But there is no longer a centre console in the new generation. "I noticed that straight away," says 31 years old Manuel Eichleiter, a professional driver since 2009. Eichleiter is enthusiastic about many new features such as the free through-passage in the cab. "That is an improvement." He quickly got used to the new means of manually activating the parking brake.

Distinguishing the New Generation

The developers did not orient themselves to the previous model for the new truck, but rather to the everyday work of its drivers. This approach is noticeable in the vehicle: "The vehicle has been completely redefined," says Dr Britta Michel,



who is head of the Central HMI Research department and along with her team was instrumental in its development. The HMI team at MAN involved many test users to help develop the optimum cab equipment: from drivers for drivers.

Almost a thousand truck drivers have given their verdict as test users. Manuel Eichleiter drove many kilometres in the simulator and gave his opinion in workshops on the concept for ergonomics. Many months later he saw the result as a prototype. "I like it," he then pulls the drawers below the dashboard. "A4 fits in easily," he says contentedly. More space in the cab – because the centre console is gone. The fact that it has disappeared has further advantages.

Complete Interior Redesign

The cockpit and cab have been completely redesigned to make the driver's work as easy as possible. All user interfaces are designed for ease of operation. The driver's workplace and living space are more comfortable than ever before.

The gear selector lever is now located on the right-hand side of the steering wheel; an ergonomically shaped steering column switch in a convenient position. Its rotational movements are optimally matched to hand movements. The driver uses the steering column switch to operate automated driving programs, a further development of the previous gear shift programs. Their operation has become much more convenient – thanks to uniform design of the graphic display screens. These are designed so that every driver, regardless of their training and experience, can manoeuvre the vehicle as efficiently and safely as possible.

New Digital Display

The large digital TFT display behind the steering wheel is also new. The speedometer and rev counter are only displayed virtually and cropped, leaving plenty of room in the middle for more information such as which assistance systems are activated. The imagery is self-explanatory and concise.

"There are more and more functions in the cockpit, but they still have to remain clear for the driver," explains Holger Mohra, Head of Vehicle Functions and HMI. "Our new concept is a success in this respect."

Readability for All

The basic ergonomic design of the cockpit provides a clear separation between display and operation. The distance between large displays and driver is based on the television principle: a comparatively large distance improves readability for drivers of all ages.

The driver navigates through the main menu with the large lower rotating ring on the MAN SmartSelect.



The new MAN Truck Generation: Two new MAN vehicles from the TGL (right) and TGM (left) series, both with the CC cab, can be converted into fire service vehicles.

The controls, on the contrary, are all convenient and can be accessed safely without moving from a seated position. The infotainment and navigation system, which are displayed on a 12-inch screen, have been significantly enhanced. Control is via a rotary push-button integrated into the dashboard: the MAN SmartSelect. It can be operated blindly via a menu selection ring. Supported by a palm rest, the infotainment system can be operated safely and intuitively via MAN SmartSelect, even given the vibration influences of an air-sprung driver's seat – always while maintaining a comfortable seating position. "A real highlight that nobody else offers," says Manuel Eichleiter. **f**



Adding Blue to Go Green

According to the National Automotive Policy 2020, commercial vehicles are to start using Euro V engines as of September this year. We take a look at what that means in more detail.

Looking at the National Automotive Policy (NAP2020) released by MITI, the following two events are planned as from September 1st 2020:

- Interim EEV standards will be released for heavy commercial vehicles with a Euro V
- For many years imported vehicles have been entitled to a road tax rebate via a Green Engine certificate. The Green Engine specification will be upgraded from Euro II to Euro V.

Commenting on this is Tom Kuiphuis, Presales Director of Scania Southeast Asia "Since Heavy commercial vehicles with a Euro V engine need Adblue aka Diesel Exhaust Fluid (DEF), it is crucial that by then this is widely available in Malaysia for an attractive consumer price. At Scania Malaysia we are wondering when the roll out of AdBlue to the gas stations throughout Malaysia will take place. We would like to get a better understanding of how this is planned."

What is Adblue?

Diesel exhaust fluid (DEF), also commonly known as Adblue, is a urea-based solution that used in conjunction with a selective catalytic reduction system

installed in the exhaust reduces harmful nitrogen oxide emissions from diesel engines. DEF is composed of 32.5 percent high-purity urea and 67.5 percent deionized water. DEF is clear, odourless and safe to handle.

The solution is added to a separate storage tank in diesel-powered vehicles equipped with selective catalytic reduction (SCR) technology. The fluid is injected into the hot exhaust stream of the vehicle and helps break down the nitrogen oxide gases in the exhaust into nitrogen gas and water vapour, both harmless to the environment.

An Inexpensive and Efficient option for Lowering NOx Emissions

Nitrogen oxide (NOx) is produced from the exhaust of diesel vehicles and is a major contributor to smog and other air pollution. Exposure to

NOx can also lead to respiratory and heart disease. This is why in 2010, the U.S. Environmental Protection Agency (EPA) mandated that all new diesel engine vehicles reduce NOx emission levels by 90 percent.

Improved Engine Performance and Fuel Efficiency

According to some sources, the combination of DEF and SCR technology not only reduces NOx emissions, it actually improves a vehicle's horsepower by making diesel engines run more efficiently, resulting in fuel savings of up to 8 percent.

Easy to use

Any diesel vehicle with SCR technology can use AdBlue. There are no special filters or absorbers required. The driver simply fills their AdBlue tank periodically and the SCR technology handles the rest. Urea consumption for a Euro V engine is about 5 percent of the diesel consumption. One litre AdBlue is therefore lasting about 40-80 kilometres. Since the EPA regulations came into effect, SCR technology is quickly becoming the industry-standard on new diesel vehicles.

Widely Available

Euro V and Euro VI emission norms have been introduced in a number of countries. As a result, many truck stops or petrol stations now offer diesel exhaust fluid that can be pumped directly into the respective tank. It can also be bought in easy-to-handle containers in various sizes at auto stores, petrol stations and other retailers. In Singapore, several companies have started their own production of AdBlue, under their own brand name.

Don't Go Without it

As with many other functions of your truck, you need to use them in the right way to be most effective and you may damage the vehicle. If you don't use Urea you:

- 1) won't get the emission level the engine is designed for. Since there is no exhaust after treatment, it is basically a Euro 'nothing'.
- 2) stop AdBlue from 'flowing'. The water will evaporate and the Urea will crystallize. After some time it clogs up the mixer and injector and it will result in a (potentially expensive) repair to get it back to function.

- 3) don't fulfill the NOx levels the engine is designed for and depending on the engine management, the engine will give reduced power when NOx levels are exceeding the limits. Depending on the programming you may not be able to start the engine again once switched off.

However, some imported trucks are still intact with the SCR technology bolted onto the exhaust system. An source that would like to remain anonymous told Asian Trucker that No 3 is often bypassed in Malaysia with a 'gadget' that simulates the right NOx level. 1) and 2) still remain in that case.

What Transporters Think

We asked Benjamin Phang, Trucking Consultant, about his views about this change. First we wanted to know if he thinks that transporters can bear the cost of high tech trucks that would have Euro 5 Engines. "Except for petroleum company transporters and other specific chemical transporters, I don't see transporters requiring such high tech vehicles given the cut throat transport prices on offer."

He further stated that fuel efficiency is not really a key factor, given the cost of diesel in relation to transport prices is based mainly on overloading. One of his concerns is that the distribution network for AdBlue will not be ready by September either.

"There are certain aspects impacting the daily operation of a transport company. Making sure that a truck has sufficient AdBlue is a step that needs to be done as a pre-drive check." He reckons that our drivers are diligent enough to carry out these tasks though.

That is not a problem, given the training." At the same time, he does not see any advantage for certain truck brands as generally truck owners are very price conscious.

"Is the transport industry has been educated about this coming change and is prepared for this change? That is a big NO. The MOT is not at all active in this respect. SPAD, now APAD, was enacted to take the transport industry forward but what was intended did not measured up to what was implemented."

National Emission Test Centre

In connection with the NAP 2020, a National Emission Test Centre (NETC) will also be established. It is an independent entity and recognised as a national laboratory. It is owned by Malaysia Automotive Robotics and IoT Institute (MARii), an agency under the Ministry of International Trade and Industry (MITI).

NETC provides testing facilities in measuring vehicle emission pollutants and fuel consumption. NETC is the most advanced emission testing facility in the ASEAN region (measures up to Euro 6d Emission Standard - WLTP). **F**

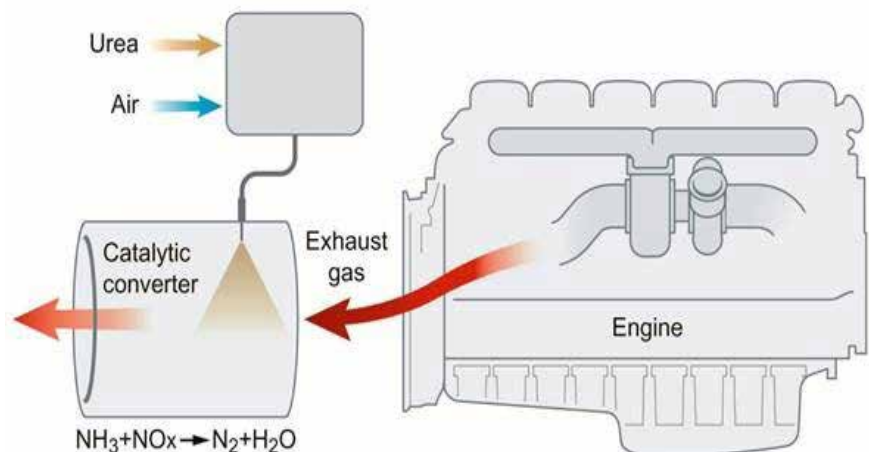



Waste Collection Trucks as Essential Tools in a Crisis

No matter what, garbage needs to be collected in order to prevent follow-on issues. Trucks are essential for this task. In this exclusive feature, two companies share insights into what it takes to keep a country clean and operating in any crisis.

While the outbreak of Covid 19 is very tangible and current, other scenarios are also thinkable during which waste collection would still have to be carried out. Under the Prevention and Control of Infectious Diseases Act 1988, waste management is listed under Regulation 2, which is the essential services in Malaysia, as gazetted in the Federal Government's Prevention and Control of Infectious Diseases (Measures Within The Infected Local Areas) Regulations 2020. The services are deemed as essential or critical to public health or safety, and such services are carried out according to schedule as outlined in the Collective Agreement under the Solid Waste and Public Cleansing Management Act 2007 (Act 672). We spoke to D L Ho, CEO, SWM Environment Sdn Bhd (SWM Environment) and Ramli bin Mohd Tahir, Managing Director of KDEB Waste Management (KDEBWM) on what it takes to keep collecting waste in any crisis.

KDEB Waste Management is the largest service provider in Selangor with around 1 000 trucks and is managing the waste in the state. "Selangor is the most developed state in the country with over a million tax payers as well as over a million foreign workers. These are big numbers, waste wise. We are talking about 7 200 tons per day of generated domestic waste," said Ramli. Another 3 000 tons per day comprises of bulk waste and public cleansing that KDMB handles. This makes up about 30 percent of waste produced in all of Malaysia. Using their expertise, KDMB could also operate in other states or even countries. However, in line with the current directives, work is limited to Selangor.

Some may ask why waste collection and transportation is considered an essential service. Every day, each of us generates waste. "It is one of the few industries that will not be affected in any kind of crisis or economic downturn." Failing to collect the refuse may cause outbreaks of other health related issues, such as Dengue or Malaria outbreaks. "This is why it is still very important to keep sweeping streets, cutting grass and to ensure that drains are free from obstructions caused by littering," he explained. Extending from here, Ramli said that his services to keep the state clean are also contributing to the growth of the country and, more importantly, to the image of the country as Malaysia surely does not want to portray itself as a third world country. "Therefore, planning is crucial. We

need to ensure that we have enough trucks and that these trucks are fully operational at all times."

While the laws generally classify the collection of waste as an essential service, there are specific measures that needed to be taken in view of the Covid 19 outbreak. Ramli detailed that procedures had to be adjusted accordingly, for instance, social distancing, additional PPE has to be used and asking HQ staff to bring food from home instead of going to food courts or restaurants in order to reduce contact with others. Almost 9 000 staff and contracted workers in 12 offices in Selangor have been asked to take extra precautions although the operations continues as usual. "We still have to ensure that our lorries arrive on time and that we meet all the KPIs, although here in the headquarters we work on rotation with half the staff working from home."

What Ramli observes is that there has been an increase of seven percent in volume of waste collected from private homes when the Movement Control Order was initiated. Meanwhile, this number has increased to 14 percent. "This is to be expected as people now all cook at home and do not spend time eating outside in Mamaks and restaurants." As hardly any commercial activity is taking place, there is hardly any waste to be



collected from businesses. "Naturally, we are still receiving complaints that the collection has not been carried out correctly and we have to check these issues. What we find is that, in most cases, people bring their rubbish out late in the day, after our lorries have already passed through. We monitor the movement of all our lorries via telematics."

One aspect Ramli highlights is the need for quality equipment in order to not only provide superior service in normal circumstances, but especially when a crisis has the country in its grips. "For instance, the last batch of compactors we obtained included 61 units of HYVA compactors. The quality of the steel, the hydraulics is fantastic and in situations like this, this is worth every cent we invested." Since the operation will not be stopped even in a crisis, the equipment needs to be fit to run 365 days a year, no matter what. "Now, more than ever, I am very happy with the products we bought from HYVA."

Operating in several states in the country, SWM Environment Sdn. Bhd. (SWM Environment) is one of the largest companies in Malaysia handling the collection of waste. SWM Environment is responsible for the management of solid waste and public cleansing in the states of Johor, Melaka and Negeri Sembilan. They

have a workforce of more than 8 000 employees and are located in 27 districts in the three states with own depots and workshops to maintain a fleet of more than 1 000 vehicles and equipment comprising compactors, mechanical streetsweepers, vacuum desludgers, waterjetters, beachcombers, Roll on Roll off trucks, tippers trucks, grass cutting machines, backhoes and others.

SWM Environment uses their trucks to collect municipal solid waste (MSW) from more than one million premises comprising residential, commercial and institution premises. Collection of industrial waste which is not included in their scope of service and is handled by the private sectors though. An average of 5 000 tonnes of MSW is collected per day and is disposed of at the nearest sanitary landfills located within the districts.

This being one of the few times the country is in an actual state of emergency and Ho makes some interesting observations. "In general, a clean and sanitary environment is crucial for a healthy and comfortable living. Hence timely collection and correct handling of waste can contribute towards preventing unwanted diseases and infection from spreading."

During Malaysia's Movement Control Order (MCO) more residents will have to remain indoors at home as most businesses have to temporarily halt operations and their employees to work from home. The waste generation from residential areas have seen quick increases during this period, requiring timely collection to avoid odour from increased and / or excessive pile-up of trash at households. He said that "Many household have also taken advantage of the period to carry out spring cleaning and an increase in bulky waste which is part of SWME's weekly collection service has been encountered. Even more crucial is the need to ensure that contaminated waste is taken care of timely and properly to ensure a clean and sanitary environment to prevent spread of infection."

SWM Environment's operation as such has not been affected by the MCO implementation. However, stringent safety measures have been implemented to ensure that the workers are safe and protected from infection whilst carrying out the daily operations.

These include:

- Work locations and vehicles are regularly disinfected in the interest of our employees to ensure that they are working in safe environment protected from COVID-19.
- Providing additional Personal Protective Equipment (PPE) to workers – face masks, face shield, hand sanitisers, special clothing for collection from high-infection areas, etc.
- Practice social distancing minimum of one metre during all operation briefings (apart from conducting them in smaller groups of no more than five personnel).
- Active monitoring of staff health – checking staff temperatures at the offices, as well as developed proper flow of communicating and reporting on any potential health risk or symptoms from our frontliners and employees. Any staff found with symptoms are immediately sent for medical check-ups as well as being sent home for quarantine where necessary to prevent infecting others.
- Series of communication for both office and field workers were developed to share on prevention tips as well as practices to stay safe and avoid the COVID-19 infection: how to wear and properly dispose gloves, how to wear and properly dispose masks, how to properly wash hands, safe practices at work and at home, how to look out for symptoms & report on suspected cases, etc.
- Health Department officers were invited to deliver talks and staff briefings at various state locations – regional as well as district offices, even prior to the MCO and escalation of the COVID-19 situation in Malaysia, as a preventive measure by educating employees on safe practices.
- All employees are reminded to maintain high levels of hygiene and regularly sanitise – sanitisers and medicated soaps are provided at all key areas at the workplace.



Specific Operational Considerations for Waste Collection during a Crisis

Q: Do you need to re-define the routes the trucks are moving?

A: No major changes made to the collection routes as collection is ongoing as scheduled. However, apart from the additional bulky waste collection, collection routes have been added to include some quarantine centres due to Government instructions.

Q: Is waste transported across state borders? How do you deal with that?

A: Transportation of waste across state borders is not permitted unless approved by the relevant authorities. Waste is collected and disposed at designated disposal facilities within the respective states.

Q: How do you keep your trucks operational at the moment, seeing that workshops are not operating at full capacity?

Both companies have in-house workshops with the capability to handle all minor repairs and scheduled maintenance. Special teams look after the trucks and their maintenance and inspection schedules to ensure operational readiness at all times. In cases of accidents, replacement vehicles are on standby. Hence, to-date there's no impact to us on this. However, there are some challenges in obtaining spare parts on time during this period, which we hope will be resolved with the recent announcement from the Federal Government regarding granting permission for workshops and hardware businesses to re-open during the extended MCO period.

Q: Would the KPIs or the Schedule Change in a Crisis?

A: All KPIs are still being monitored by the authorities in accordance with the concession agreement. Waste collection and cleansing services are carried out according to the standard service levels and frequencies. The compactors or waste collection vehicles are fully equipped with GPS monitoring device which is monitored in real time via a Computerised Command and Control Center based at the Government Authority's premise and is jointly monitored by SWM Environment and the Government Authority.

The central office in Kuala Lumpur remains open, although with very minimal workforce as employees from Head Office has been working from home. This is assisted by a highly computerised integrated waste management system SWM Environment has established where its entire operations can be managed and monitored remotely and is well prepared to continue to manage the operations from office or from home. Over the years, SWM Environment has put in place several electronic processes to replace the manual processes to manage and monitor its operations from Human Resources to Fleet and Customer Relations Management.

The availability of mobile applications, smartphones and computers is able to effectively keep the workforce at the Head Office down to its regional and district offices as well as the field well-connected on day-to-day work planning and execution. Internal meetings are mostly conducted via teleconferencing or group chats, and if face-to-face meetings are crucial, they are kept to the minimum with no more than five personnel in attendance along with the practice of social distancing.

In addition, the four regional offices that are central for each state location are also operating at the Federal Government's recommendation of not more than 50 percent of the staff working from the office. Employees at those SWM Environment offices work from home on rotational basis to ensure that reduced workforce are out at the offices each day. All of these measures could also be taken in case of other natural catastrophes or emergencies.

Generation of waste at commercial and institution areas has reduced slightly during the MCO period as not all commercial and institutions are operational during this period. Although the shops are not operational most of the premises are still occupied by the shop owners / families. However, with most of the population staying at home all day during MCO, generation of waste at residential areas has increased significantly. Some of this are linked to increased use of packaging for takeaway food as well as home shopping during the MCO lockdown period - we have seen the need to increase collection frequency as waste generation at residential areas increased by about 20 percent since the implementation of MCO.

Food waste collection from residential areas increased to about 10 to 15 percent, whilst those with more time to spare at home took the opportunity to occupy themselves with gardening, tidying and major cleaning-ups, resulting in bulky and garden waste increase of about 20 to 25 percent.



Q: How are other countries handling this situation?

A: Many countries have gone on lockdown mode, although some nations have more freedom of movement. Nevertheless, in other countries, just as in Malaysia, waste management and public cleansing activities goes on as usual if not more, with the need for some additional sanitisation operations especially for high alert areas. The need for taking extra precautions such as providing additional PPEs and SOPs resonates throughout the industry worldwide. Some countries which have

technology and systems to provide prompt and effective COVID-19 alerts for all citizens are also able to warn of households affected by COVID-19 so that workers could take extra precautions when operating in those areas.

In addition, China and some countries in the European Union have separate collections for used masks and gloves as well because their governments require its citizens to wash and throw them in separate bags from household waste. **F**

SPECIAL OFFER FROM ASIAN TRUCKER!

Books dedicated to wheel alignment, more so on wheel alignment for commercial vehicles, are very rare indeed. You will not find them in bookstores. Wong Thiam Boon has poured decades' worth of experience into this book and you can now buy it from Asian Trucker for a special price.

If you want to learn more about how to reduce the cost of operating your fleet through correct wheel alignment, then wait no longer and grab a copy of this practical guide book.

RM 120.00 or SGD 40.00 + Postage
Discounts are applicable for bulk orders of five copies or more.

"This practical and resourceful book will be an asset to any fleet operator or workshop that wants to improve the performance of commercial vehicles. It is TB Wong's experience of decades working with wheel alignment systems that shines through and makes this a must-have item for anyone that is serious about their transportation business. The industry had to wait far too long for a resource like this and I am excited to see TB Wong's knowledge now being available to the market."

Stefan Pertz,
Editor, Asian Trucker Malaysia
Editor, Asian Buses

Available from Asian Trucker. Order via info@asiantrucker.com

**ASIAN
TRUCKER**

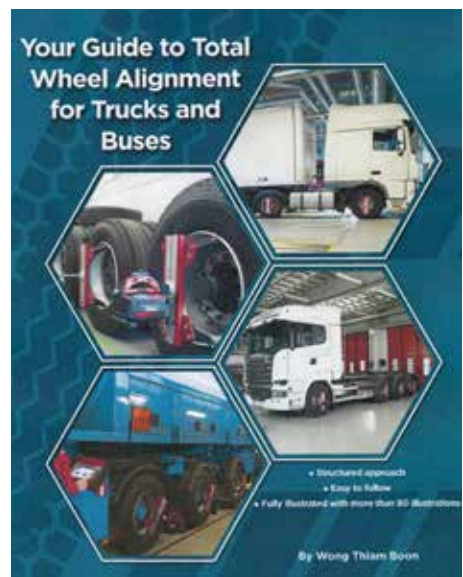



With Inner Vision Opened, Horizon Group Expands

The Horizon Fuel Cell Group has launched Hyzon Motors, a hydrogen vehicle company focused on heavy-duty FCEVs and specifically fuel cell stacks exceeding 100kW. Hyzon's vehicle line due to launch this year are the 40t trucks. Also in the pipeline, but for launch at a later date, are the smaller trucks in the 15 to 40t range.

Next year, the company based in New York wants to add other light commercial vehicles and types on the van platform. This includes road-trains with a gross weight of up to 140 tonnes set for commercialisation in 2021 in Australia. Their main focus for now is Australia, in particular West and North East. Minerals and some other industries have started to invest in Solar fields to generate their own Hydrogen to decarbonise and reduce their operating cost. The Pilbara region in NW Australia for example imports about three Billion litres of oil a year: so they are ready for change, a change that may come with a new generation of trucks.

Hyzon claims to be the first US manufacturer to specialise in PEM fuel cell modules with more than 100 kW. The technology comes from Horizon Fuel Cell, that founded Hyzon as its new commercial vehicle subsidiary. George

Gu, CEO of Hyzon Motors, doubles as Chairman of the Board of Directors of Horizon Fuel Cell. He said: "We have seen incredible growth in Asia in recent years at Horizon, and now with the experience gained from hundreds of trucks in commercial service, we aim to bring our technology to the roads of the world." Gu also expressed the hope that their technology will help the world decarbonise transport "much faster than people currently believe is possible".

Their trucks offer an Advanced Zero Emission Hydrogen Fuel Cell System, highest levels of safety through Advanced Driver Assistance Systems. State of the art telemetry systems make Hyzon 40 to 80 ton trucks a benchmark for the 21st Century.

With hundreds of trucks including the only 150kw Fuel Cell Trucks in the world they already have millions

of kilometres of experience to bring to life their new H3 trucks, which are coming to roads around the world by November 2020.

Available Models

Chassis Type

- 6 x 4 Prime Mover (40 to 80 ton GVM)
- 6 x 4 Rigid Chassis (40 to 80 ton GVM)
- 8 x 4 Rigid Chassis (40 to 80 ton GVM)

Power System

- 150 kW Hydrogen Fuel Cell Hybrid Electric (40t)
- 200 kW Hydrogen Fuel Cell Hybrid Electric (40-60t)
- 370 kW Hydrogen Fuel Cell Hybrid Electric (80t)

Advanced Safety Features

- Emergency Forward Braking System
- Adaptive Cruise Control
- Lane Departure Assistance
- Unique driver Auditory Health and Awareness System
- Sleeper Cab-over design
- High Safety Design Chassis and Cabin developed together with one of Europe's top Manufacturers
- Low cost of operation with only a handful of moving parts and estimated life of system well over one million km
- Multiple storage and range options 





The Talented Volvo Trucks Malaysia

Any organization is made up first and foremost from people working for it. With a wide range of career choices, talents have a lot of options. We spoke to Volvo Trucks Malaysia to find out what they are doing to secure the best and brightest to work for them.

Everyone is talking about their need for qualified staff, both for offices and in the workshops. Fresh entrants into the workforce have a myriad of options for their first job while companies need to have a “right fit” to ensure that the hired staff is aligned with the company’s vision and mission. Asian Trucker spoke to Mitch Peden, Managing Director, Volvo Trucks Malaysia about their approach to talent acquisition.

Peden has a lot of input on this subject as their approach to talent recruitment has been in place since the 90s. Since then, Volvo Trucks Malaysia (hereafter Volvo) has worked with colleges and other institutions. The obvious search would be for “mechanics”, where Volvo is looking for passionate and skilled men and women to join the organization. In some cases, learning institutions have even adjusted their curriculums to meet the needs of Volvo and other commercial vehicle brands. Besides the theory, students also have the opportunity to have hands-on experience on trucks, working as apprentice in Volvo. “We have been offering hundreds of apprenticeships and internships over the years. It is during such placements where students see various aspects of the business, not just in the workshop, but in HR, Accounts, and Sales and Marketing area to show them how interesting the industry is to work in.”

“We hope to attract the most talented, motivated and enthusiastic candidates. The fight for talent is a tough one as it is not just our industry trying to woo them, but others too. The more people we can get exposed to the Volvo brand the better,” he elaborated. One of the success stories he reported on was that some of the interns actually stayed on and are still in the business after many years. “One of our challenges is to promote this industry, transportation as a whole, as an industry one would want to work for.” This, Peden remarked, is likely a global issue. “The HR Department not only needs to promote the company as one which offers good career opportunities, but the industry too as an interesting one, not just for male, but offers plenty of opportunities for female as well.”

Besides the issue of career choices, jobs also change and the requirements of a truck maker would change. The job that we may call a “mechanic” is slowly, but very surely, evolving into a highly skilled function that requires computer and

engineering knowledge. “Eventually, we may need to hire electrical or automotive engineers as the trucks we are selling are offering more in terms of automation, electrification and connectivity.” As a consequence, Peden muses, one would have to talk to different institutions and schools to get the best fit.”

The issues Volvo is facing are not unique though. The recruitment process may be very similar in other



countries. It is about tapping into the right professional networks and to talk to the right people to let their networks know that there are job opportunities. "Word of mouth is very important. However, the selection process is extremely important." When it comes to the interview process, it may not just be about the skills but also interpersonal capabilities.

Stigmatized, Millennials will be making up a big portion of the workforce soon. However, while many may have preconceived perceptions on how they work, Peden has a different view. To him, Millennials are highly creative and resourceful. They may be keen to work in a more flexible environment where following rules may not be paramount. He said that "It is obvious that we need to provide a work environment that is fun to be in. And that applies to any generation. For some functions, like marketing for instance, this creativity is what we need. In other administrative functions, adherence to processes and compliance are vital. When hiring any talent, it is obviously about ensuring that one has the right candidate for the job, no matter when they were born." Volvo welcomes diversity, as this is one way of moving the brand forwards.

What showed now, though, is that the current situation with the MCO poses a unique situation where some of that creativity may be helpful, while some staff may struggle with the notion of working from home. "It is also now where companies show their real face." As anyone can have lengthy statements about the care for their staff, it is in unusual situations like now where the ethos of companies shines through. "Now we can see how much of that is true when companies walk the talk. I think we can be proud of what we have done here in Volvo in terms of keeping our personnel safe."

The one thing Peden advises against is to depict the organization in a manner that distorts the reality. "Businesses should not overpromise on what they are. We need to present ourselves correctly and tell new entrants exactly what they can expect from us when they join us. In return, we would expect that applicants are as truthful when they discuss their abilities with us."

Concluding, Peden urged students and fresh grads to join one of their many programs to learn more about the opportunities that lay in waiting for them. "It is our duty to hire the best people, as that is what our customers expect of us: the best product and the best service." According to him, it is through these programs that Volvo identifies these talents and he hopes that more young people would make use of these channels such as vm.hr@volvo.com

Volvo Trucks started Technical collaborations long ago; in the 90s. Since then, the brand worked with various colleges and automotive institutes including Workers Institute Technology (WIT) in late 90s, Kolej TAFE Seremban (since early 2000s) and Institute Kemahiran Tinggi Belia Negara (IKTBN) (since 2000s)



on technical know-how development. These co-operations are supported by two in-house trainers. Other noteworthy activities include these collaborations:

Kolej TAFE Seremban

- Participated in Kolej TAFE Seremban Open Days, donated engine display unit and half cut cab unit among other activities

National Youth Skills institute (IKBN) under Ministry of Youth & Sports (KBS) Malaysia

- IKBN has acquired few units of Volvo FM (FM9, FM10, FM12 etc) and FL to be used for the students' hands-on learning experience
- In Dec 2017, donated a FM half-cut cab for educational purpose to IKTBN again
- Offers internship placements (Blue Collar) according to operational needs
- At least once a year study tour at Volvo dealership, participate in their career fair
- Offer Train the Trainer programme to IKBN lecturers

Others

- Participated in Career Fair in INTI College (Inlay): 2014 and 2015
- Career Fair IKTBN – Kuala Langat – 22 Sept 2019
- Participated in INTI Leadership Series Talk in INTI College Subang Jaya and Nilai, 2015 and 2019

Achievements

- Received Employer of Choice (Silver level) in 2015 and 2017 by Ministry of Malaysian Institute of Human Resource Management (MIHRM)
- Volvo Trucks Malaysia is shortlisted for the Technical and Vocational Education and Training - TVET Valued Industry Partner Award organized by Ministry of Youth and sports Malaysia. This recognition award is given to all industry partners that collaborate with government mainly Ministry of Youth & Sports in the development of the youths and those pursuing Technical courses with IKTBN. The winner will be selected by Jawatankuasa Kabinet Pemerkasaan TVET, with results yet to be announced 



By visiting many of the body builder assemblers, you can find a number of these specialists still working in these companies and sharing their knowledge.

Somehow in parallel, Scomi Special Vehicles, a branch of Scomi Corporation involved in the O&G, Monorail project, Bus assembly and Various engineering; was assembling specialized vehicle too. Scomi Special Vehicle but unfortunately ended production a couple of years ago.

CME, Guthrie, Pesaka Astana in the '80s begun assembly of various specialized vehicles too.

The Asian crisis of 1997-8 brought a bit of a temporary brake to the growth but in 2000 the restarting was better than ever.

With a restarting happening, it is obvious that more companies jumped in to the business and a keen competition started.

Nowadays, the world of specialized vehicles is divided mainly into - Bus body manufacturers – Road Tankers for Oil products and edible oils – Cements, powdery form chemicals and animal feed tankers – Emergency, Civil Defense and ambulances – Municipal, Road sweepers, Aerial platforms, Garbage compactors, Sewage maintenance -

Amongst the Companies which are active in each sector, are:

Road Tankers for Oil products and edible oils – Chip Ngai Engineering Works Sdn. Bhd., Jihtra Engineering Works Sdn. Bhd.

Cements, powdery form chemicals and animal feed tankers – MPSI Steel Industries Sdn. Bhd.

Emergency, Civil Defense and ambulances – AVP Engineering Sdn. Bhd., CME Group Bhd., Artabara Teknik Sdn. Bhd.

Municipal, Road sweepers, Aerial platforms, Garbage compactors, Sewage maintenance – Chip Ngai Engineering Works Sdn. Bhd, Artabara Teknik Sdn. Bhd., A-Plus Manufacturing Sdn. Bhd., Duromac Sdn. Bhd., MPSI Steel Industries Sdn. Bhd., Ultra Efektive Sdn. Bhd., Zenith IG Sdn. Bhd., Syarikat Lezan. 

Malaysia – Special Purpose Vehicles

Giovanni Siano of Integrated Fire Technologies provides insights into this market segment in this brief history of SPVs in the country

Where it all started: Wagon Engineering Sdn. Bhd. located in Shah Alam was in the 80's the pioneer company in designing specialized vehicles for civil defense, army, airport, various utilities and municipalities. A part from the oil road tankers that already a number of other major and minor companies.

Wagon hired a number of young graduates and already experienced engineer and technician and began the manufacturing of many kind of vehicles, some of them still on the road now. Operations continued until the second half of the '90s where the company had to close for some reasons.

It was obvious that the personnel had to find employment through various companies which were starting to grow to fill the need for a nation which was growing rapidly with an ambitious infrastructure network.



SCHEUERLE Trailer Still in use at Flückiger after 56 Years

From 1964 to 2000, E. Flückiger AG used a low-deck trailer from SCHEUERLE for transporting construction machinery. The fully restored, robust low-bed vehicle is still on the road 56 years later and clearly demonstrates just how durable and robust the vehicle technology "Made in Pfedelbach" is.

In 1964, Fritz Flückiger, the then head of E. Flückiger AG (FLAG) based in Rothrist in the Swiss canton of Aargau, purchased a T3641L low-bed trailer from SCHEUERLE, now a subsidiary of the Transporter Industry International Group (TII Group) owned by the Otto Rettenmaier entrepreneurial family. At this particular time, FLAG specialised in the trading and recycling of scrap iron as well as earthwork operations. With the vehicle from the production facility in Pfedelbach, the Swiss transport company transported construction vehicles to a range of destinations. Right through to the year 2000, the low-bed trailer from SCHEUERLE reliably performed its job in the tough day-to-day business of the construction and waste disposal sector.

Trailer reliably carries out its job for 36 years

After an impressive 36 years, Heinrich "Heini" Flückiger - Fritz Flückiger's son had meanwhile taken over the running of FLAG - sent the robust vehicle into a well-earned retirement. However, the thinking was that the tried and tested transporter should not simply be written off. It is something very special that the trailer managed to survive so long in the tough business of transporting construction machinery. Heinrich Flückiger was very well aware of this too. "The low-bed trailer from SCHEUERLE is an extremely robust vehicle," confirmed the director of E. Flückiger AG. Heinrich Flückiger therefore parked it in a secure area at the depot in Rothrist. For a long time, he dreamed of restoring the vehicle to its former glory. However, managing the company which has now grown to 85 employees has prevented the enterprising entrepreneur from tackling the restoration.

Returned to As-delivered Condition in Two Months

Heini Flückiger's two daughters knew of their father's great wish to have the trailer, tractor as well as the load restored. For his birthday at the beginning of the year, they - together with the FLAG employees - gave him a very special present. While Heini Flückiger was away enjoying an extended holiday, the daughters mobilised the specialists in the company's own workshop. Here, the trailer was finally completely overhauled whilst particular attention was paid to the details - 56 years, including 36 years in the demanding construction and

waste disposal business, obviously will leave no commercial vehicle unscathed.

SCHEUERLE trailer now gleams in almost perfect condition

The highly motivated FLAG employees needed less than two months to strip down the vehicle and then restore it to virtually to the condition it was in when it was originally delivered. The relatively short time that was required is further evidence of the excellent intact basic structure of the SCHEUERLE trailer.

First public appearance of the restored trailer at the Weiach Historik

The refurbishment team also restored the tractor unit, a Saurer D330BN 4x4 which was built in 1981, as well as the contemporary load, a Link-Belt crawler excavator produced in 1966. Now the trailer, tractor and construction vehicle are ready for the next tour. Heini Flückiger plans to regularly attend events for veteran commercial vehicles in order to showcase his own historic vehicle combination. First on the list is the Weiach Historik - a meeting for historic construction machinery and dumper trucks on 23 and 24 May 2020. Here, all fans of veteran commercial vehicles can see for themselves just how durable a low-bed trailer from SCHEUERLE really is. **F**



Huajing got your Trailer Parts

Established in 2002, Huajing is one of the biggest semi-trailer spare parts manufacturers globally.

Known as Huajing, the brand was established by Guangzhou Huajing Machine Manufacture Co, Ltd and Guangdong Huajing Auto Spare Parts Manufacturer Co, Ltd, which covers an area of 400 000 square meters and has more than 800 staff. Production processes include forging, casting, welding, machining, stamping, heat treatment, hot extrusion, intermediate frequency, surface treatment, mould design and manufacturing etc. With more than 17 years development and innovation, Huajing has since become a leader in the industry of semi-trailer axle manufacturing.

As a company, Huajing is dedicated to the R&D and manufacturing of semi-trailer spare parts, German and American type axle, mechanical suspension, air suspension, bogie suspension, argo bogie suspension, landing gear and beyond. The

company currently has a maximum production capacity of 500 000 axles, 150 000 suspensions, 150 000 landing gears, 1 000 000 brake shoes, and 80 000 tons forging parts. With this, it can meet the growing demand of the market and continuously provide qualified products and satisfactory service to customers.

Well Equipped

Huajing has modern factory buildings, equipped with over 300 sets of advanced production equipment, including

- CNC machining centre
- CNC grinding machine
- High precision welding robot
- Four guns auto-welding line
- Fully automatic extrusion line
- 40T-BOOT hydraulic press machine
- Automatic roll forging line
- 125KJ electro hydraulic forging hammer
- 1600T electric screw press, and
- Advanced heat treatment equipment.

The automation of all these equipment has reached global leading level. All the key parts are processed by PLC equipment according to the international standards to ensure stable quality.

Principled Quality Approach

The company's management insists that "Talent is the fundamental for business survival", and Huajing has a team of more than 800 talented staff, in which over 50 percent have college diplomas. There are about 35 people in the professional R&D team and most of them have medium or higher major qualification. With rich experience, R&D team can explore the new product efficiently, optimize design and develop as per customer's requirements.



Benefits from American Air Suspension Series:

Lighter in weight by 448 Kg as compared with traditional mechanical suspension (Tridem Suspension) Additional benefit for increase in payload capacity of USD 4704

(Considering Average transport cost of USD 0.71 Ton for 150 000 Kg 0.448KG X 0,07USD X 150,000 Kg = 4704 USD)



Huajing has high quality standards for its products, and insists that "competitiveness comes with quality". Currently, the Quality Control department has reached a count of 40 talented staff; every procedure is under strict quality control from raw material to finished products, following the principle "no defect material in warehouse and every production step is qualified". Huajing aims to make sure 100 percent of products are up to standard. Now, HUAJING owns the independent testing centre, conducting, among many others, fatigue test, salt spray test, metallurgical analysis and three coordinates test.

Main Features of American Air suspension Series:

Extremely light in weight, main beam structure is welded by stamped high intensity metal sheet Maintenance free integrated welding structure for main beam and axle joint, no U bolt, no regular nut fastening.

Use of big rubber steel bushing for air suspension main pin sleeve can absorb impact force better. Product layout distribute more impact force to air bag and less to bracket, featuring excellent air bag absorption of impact load.

Main Feature of Euro Air suspension Series:

Smooth driving - Regardless fully loaded or empty loaded, vibration from vehicle movement effectively absorbed.

Comfort - Comfortable driving with less twisting and shaking to alleviate fatigue.

Safety - Helps maintain even distribution of axle load, reduces vibration and improves braking efficiency.

Convenience - Simple structure and easy maintenance.

Economy- lifting device reduce tyre wear, cut down fuel consumption, extended life of both, vehicle and axle.

ECO friendly- roadbed protection and noise reduction

Benefits From Euro Air Suspension Series:

Lighter in weight by 220 Kg as compared with traditional mechanical suspension (Tridem Suspension) Additional benefit for increase in payload capacity of USD 2310 (Considering Average transport cost of USD 0.71 Ton for 150 000 Kg 0.22KG X 0,07USD X 150,000 KMS = 2310 USD )



The Truth About Retreads

In February, Alwyn Lau of the Malay Mail wrote an article, titled: "Malaysia's ignored hazard: Trucks with bad tyres". Michael Hutt, Group Marketing Manager, Kit Loong Commercial Tyre Group responds to Mr Lau's wrong and misleading statements.

Certainly, road safety in Malaysia needs a lot of improvement (The Ministry for Transport has set a 2014-2020 road safety plan that is currently not on target, so it's clear more work needs to be done). Anyone championing road safety is an ally in the fight to create safer roads and to reduce fatalities. Some businesses do not put safety first, and even more worryingly, safety Standard Operating Procedures are not well enforced. This is cause for concern and we must pressure the right organisations, both public and private, to do their part in

improvement of these areas. It is also important to recognise that cost is always an essential control in business; the balance needs to be right, but safety always comes first, and it doesn't have to be more expensive.

However, the rest of Alwyn's article is somewhat confusing and offers nothing in terms of a practical approach to solving any issues. I want to address a few of his misleading and inaccurate points, to set the record straight:

Firstly, Lau writes: "It's an open secret that one of the most frequent causes of deaths on the highway are trucks, buses and lorries".

This is incorrect by some margin. The last fully-broken-down report (www.mot.gov.my: Road Safety Plan of Malaysia 2014-2020), citing vehicle descriptions in accidents (2013) shows that 45.9 percent of all

road accidents are motorcycles, with lorries and busses responsible for just under 12 percent. As an update, in 2018 (The Malaysian Reserve: "Road accidents are 4th major cause of death in 2018 say Loke"), Anthony Loke, then Minister for Transport said: "more than half of the (road) deaths, or about 66 percent, involve motorcyclists." A 2012 report by IATSS (Science Direct "Motorcycle fatalities in Malaysia") stated: "The analysis reveals that the highest numbers of motorcycle fatalities occur in rural locations (61 percent), on primary roads (62 percent) and on straight road sections (66 percent) ... Although fatal motorcycle crashes mostly involve 'passenger cars' (28 percent), motorcyclists are responsible for 50 percent of the collisions either by crashing singly (25 percent) or with other motorcyclists (25 percent)." So, there is no reason bases In fact to assume that lorries and busses are the most frequent cause of death on Malaysia's roads. It is mostly due to motorcycles in rural locations. Even if we assume Lau means 'just' on highways, with trucks and busses contributing just 12 percent of the overall figure, there is no possibility the comment can be true.

Lorry and bus operators need to do their part in improving safety on our roads, as heavy road users it is their



Finally, Lau asserts: "Retreaded tyres should be made illegal. Period."

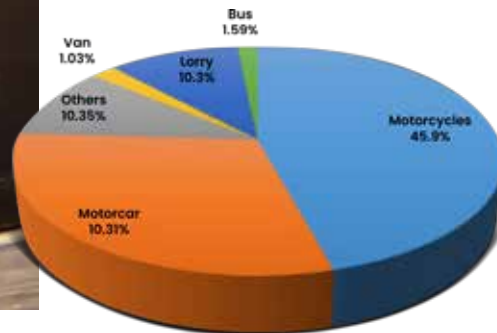

This statement shows a clear lack of understanding of both what a retread is, why it exists, where it is and should be used, how it affects the environment and their benefits to both companies and the economy. In addition, it demonstrates a complete lack of knowledge about the stringent safety steps that go into making a retread tyre.

My first point is an obvious and often used one... but it shows that retreads per se are safe. Eighty percent of aircraft tyres are retreads. In the USA, in 2020, an Executive Order was signed that required Federal agencies to replace OEM tires with retreaded tires rather than new tyres whenever possible. Most tyres used on airplanes are commonly owned by the big manufactures, such as Goodyear and Bridgestone, with guarantees of a number of take-offs and landings per tyre. No airline would run the risk of using something that was innately unsafe, no manufacturer would take the responsibility if they couldn't be sure they were also providing a product of top quality.

Let's get more into the weeds.

Malaysia has very stringent guidelines on the material used in and the actual production of retread tyres. Tyre liners have to conform to regulations set out by the Department of Standards Malaysia, (Standards Malaysia), specifically, MS 224:2005, as certified by SIRIM QAS International, which is part of The International Certification Network, which gives these products access to 37 national markets by meeting these standards. This means the materials are safe, regulated and of high enough standard for international export. Unlike ISO standards, every product must meet

responsibility to protect their drivers and other on the road, but to claim they are responsible for 'the most frequent' cause of deaths is false and distracts from us tackling the issues that could save the most lives.

Secondly, Lau concludes that there are two main 'root' causes of these accidents:

"The root cause of the above kinds of accidents can be traced to two points:

Greedy business owners cutting costs by refusing to maintain their trucks properly e.g. by retreading tyres instead of replacing tyres

Drivers being made to drive crazy long hours with insufficient rest, yet continuously incentivised to drive even more (as this reduces the need to increase the number of drivers)"

Now, as I stated, there are some businesses that do cut corners, there's no doubt about it. But it's not very helpful to point this out without being able to pin-point actions to help rectify this. After all, the law is very clear in these areas. There is a general lack of enforcement of the laws that contributes to people thinking they can 'get away with it', when cutting corners. This has to stop. The Government is ultimately responsible for the safety of all of us and this brings us to the point where we say that human nature will mean people will try to get past the rules, so we, as an industry, along with governing bodies and associations, must have a clearer plan to make sure rules are always abided by.

MS ISO 39001:2013 Road Traffic Safety Management System (RTSMS) is a great standard and is being pushed and adopted by many in the land transport sector, but the plans for enforcement are scant. It is clearly recognised that there is a lack of systematic work and commitment among organizations that affect the safety of the road transport system. This needs to be rectified. At Kit Loong, we have a set of services called SC3OCT that are fully certified and will help companies comply with both this ISO and other relevant ISOs and lead to full compliance with Puspakom inspection standards. We would be happy to work with authorities to show how we enforce these rules and standards with our clients.



quality-controlled retread tyre that conforms to all local and international certification, can be as safe to use as a new tyre.

Lau mentions at the end of the article, (we must) **“Limit the number of hours drivers are allowed to work.”** This has nothing to do with the difference of safety between retreads and new tyres, but it is very important, and we commend him if he is to focus his time in improving workers conditions of heavy vehicle drivers. To add to this, a few other important areas need to involve both driver safety training and initiatives to create safer roads across the country.

high criteria to meet MS224. The retread production process conforms to ISO 9001:2015, a process created for ‘quality management systems’ in the provision of retreading tyres. This is a very detailed process and is adhered to globally to produce top quality retreads. Go and visit any reputable retread factory and you will see very modern machinery and processes, alongside equipment specifically designed to make the products safe. From x-ray-like scanners to look for anomalies in the casings, through to high-pressure testing, the whole operation is designed to produce high-quality, safe retread tyres.

Now, to address the main issues when it comes to retread tyres in Malaysia, so that we can actually offer some practical advice. First, only ever buy retread tyres from reputable sources, these are manufacturers who have both certification, the likes of MS224, but also those producers who have retread programmes with the big tyre brands. If a tyre brand has endorsed a manufacture, it’s likely they are of a quality you can trust.

The US and European trucking industries are both heavy users of retread tyres. In Europe’s five top wealthiest nations (France, Germany, UK, Spain, Italy), the retread market makes up 30 percent of the total truck tyre market (ey.com/fr: “The socio-economic impact of truck tyre retreading in Europe”). This equates to 3.2 million units. The US uses 14.3 million retreads for commercial vehicles. These countries have nowhere near the level of road fatalities that we do in Malaysia, but are still keen users of retread tyres for commercial vehicles. So what’s the difference and why are perceptions here so negative?

Secondly, even the best tyre will face issues if it isn’t maintained correctly, such as simple things like getting the correct inflation for the load will prolong tyre life to what is expected. These are the areas companies purchasing tyres should be focused on, and. Lau is correct to say this is their responsibility and there should be no cost cutting when it comes to safety. And the simple fact is, running a safe operation is actually more profitable than an unsafe one. A 2012 study by EY found that: “Companies in the top 20 percent of risk maturity generated three times the EBITDA as those in the bottom 20 percent.”

In a word: quality. But to add some meat to the bones, it is about three main factors: casings, process and material. Not all casings are created equally. The disparity in the quality of new tyres is vast. It’s commonly accepted that half of the burst tyres you see on the road are not in fact retreads, but cheap new tyres. The ‘big’ players invest a lot of time and money into researching the safest compounds, new ways to disperse water, better ways to run tyres hotter, how to make their casings better for retreading. All of this means that some new tyres are both very safe, will travel long distances with good maintenance and be better made for retreading (all the top companies make their tyres specifically to be retreaded, just as a lot of them will retread them and sell them again under their own brands).

Lau ends his article with the statement “Puspakom, I have spoken.” This is another clear indication of him not understanding the fundamentals about the transport industry. At the time of the inspection at PUSPAKOM every six months, a commercial vehicle may be in a perfect state. However, five months later, tyres could be worn beyond the allowed limits. In that case, it would be JPJ though that is responsible to identify and enforce upon the culprit, not PUSPAKOM. **F**

Process is vitally important in the creation of retreads. The very first part of the process is to grade the casings to make sure they are safe to be retreaded. This even involves x-raying the casings to make sure there are no hidden deformities in the casing. The rest of the process is similar to creating new tyres. Many retread factories have spent millions of ringgit on the latest technology to guarantee the best product. Often, a retread tyre will have the capacity for longer mileage than the original casing tread allowed. This is because often retreaders understand local issues better than global companies and can use the materials best suited to that environment, both in terms of natural and road environments.

Which brings us on to the final element, materials, which make up the ‘new’ tread applied to the casing. By using the best compounds, most suited to application and environment it is very fair to suggest that a well-produced,



There is Always Room for Improvement

As the academic icon Peter Drucker said, “A business enterprise has two basic functions: marketing and innovation.” And while a transport business may be easiest described as an entity that gets goods from point A to point B, there is of course a lot of innovation going on. Sometimes, those that do not keep up with innovation, or innovate themselves may be left behind and may even have to close shop.

What is Innovation?

There are many ways to look at this. Some think that an innovation must be a ground-breaking, highly complicated new technology that renders the current system obsolete. Sometimes that is the case. Oft times it can be a minor tweak or the adaptation of methods used in other industries that improves operations.

Who Should Drive Innovation?

A company wanting to gain an edge should have a culture of innovation. Ideas should be discussed openly, while roping in key people. I say key people here, referring to the drivers for example. How better to comment on this than the very people that have to execute or deal with the innovative ideas. What is mandatory is that the management creates a culture that nurtures innovation. And no idea is too radical or dumb. Look at the highly successful rock band, Aerosmith, which made it a point to have a weekly meeting to discuss their “most stupid idea for the week.”

External Pressure

Some innovations are the result of external factors. Take for instance the idea of sharing loads. At one time, one might have been contented to just move goods one way and come back empty. Now, with apps like WhatsApp, groups can be created that allow the sharing

of information about goods that can be collected. Taking this even further, specialist apps offer the brokerage of such backhaul. Surely, that is an innovative use that the creators of smartphones would never have thought of.

In other instances, it can be restrictions imposed by a government that ignite innovative thoughts. Here, emission norms come to mind, which not only reduce harmful exhaust, but through innovation in engine technology bring down fuel consumption.

I Had an Idea

I Had an Idea, but I didn’t like it. Some innovations are not practical or beneficial to a business. That said, I think it is important to continuously keep trying to make things better. Bit by bit. And if it is tiny improvements here and there, over time they will add up to something bigger. Perhaps it is also wise to keep track of ideas that have been shelved. What might be a bad idea today, could be of value tomorrow.

Don’t Stop It

In addition to increasing profit, there are other good reasons to innovate. Staff may be happier, the environment cleaner or the client more satisfied. Whatever the main driver, we should never stop innovating at all levels of road transportation. If anyone were to disagree, we can ask them to revert to horse-drawn carriages. If we hadn’t spent the last century and a half innovating, that is where we’d still be. I wonder how they would like that? **F**

Keysight, DEKRA Join Forces to Address Growing Electric Vehicle Market



Key Insight Technologies, Inc. a leading technology company that helps enterprises, service providers and governments accelerate innovation to connect and secure the world, whose primary manufacturing and order fulfilment location is in Penang, Malaysia, announced that DEKRA has selected Keysight's Scienlab Charging Discovery System (CDS) solutions to extensively test and certify the charging technology within an electric vehicle (EV) or electric vehicle supply equipment (EVSE).

The EV market is percent between 2019 and 2030. DEKRA, one of the world's leading experts in testing, inspection and certification will use Keysight's Scienlab testing charging technology to efficiently deploy EV charging solutions that conform to a wide range of charging interfaces, power grids and international standards.

The impact of EVs and EVSEs is noteworthy when powered using a sustainable energy mix over their complete lifecycles. Governments around the world are offering incentives and establishing regulation to encourage business and consumer investment in EVs to reduce air pollution and noise contribution. Keysight supports the automotive, energy and communications industries in this transition with design, test and validation solutions.

Last year, Keysight joined the Charging Interface Initiative (CharIN), an association of industry experts across the automotive ecosystem, to support the establishment of a global standard for electric vehicle charging. A common standard guarantees interoperability between electric vehicles and charging stations. Keysight's CDS solution uses a modular design that

allows users to verify the charging interoperability between any EV and any EVSE, as well as between any charging network components.

"Keysight supports technologies needed for a future that uses sustainable energy sources to deliver autonomous driving, connect car connectivity and electrification of vehicles," said Gooi Soon Chai, president of Keysight's electronic industrial solutions group. "As a result, the connected ecosystem can address a comprehensive range of test requirements related to power, sensors, communications, navigation, in-vehicle electronic networking and cybersecurity." **T**

SAF-HOLLAND awarded once again with the PACCAR 10 PPM Quality Award

The SAF-HOLLAND Group, one of the world's leading suppliers of fifth wheels, has once again been awarded with the 10 PPM Quality Award of the US truck manufacturer PACCAR Inc. - Kenworth, Peterbilt and DAF - for its locations in Singen, Germany, and Woodstock, Canada, for 2019. Only a few select suppliers who attain a defective parts ratio of 10 or less per million are granted this quality award. The SAF-HOLLAND Group has received the 10 PPM Award, which is issued on an annual basis, for the sixth time in succession for the Singen plant and for the fourth time in succession for the Woodstock plant.

In addition to achieving 10 ppm quality status, suppliers must meet demanding criteria for delivery performance, warranty support and continuous improvement. To achieve the elite quality status, the suppliers need best-in-class product design and process capabilities as well as a quality-focused corporate culture.

The plant in Singen has supplied fifth wheels to DAF Trucks in the Netherlands and Belgium since 2005. The plant in Woodstock has supplied the PACCAR brands, Kenworth and Peterbilt in North America for over 40 years. **T**

Snap Poll

Would You Consider Hydrogen as Alternative to Diesel?

No - 0%

Yes - 100%

The voting for this poll has ended

STRENX®
PERFORMANCE STEEL

ADDS VALUE EVERY DAY, EVERY TRIP, EVERY LOAD

Strenx® performance steel can meet the challenges facing the transport industry, which is constantly looking for ways to increase payload and improve fuel efficiency. Strenx® is a high-strength structural steel with extremely consistent properties, making it perfect for designing trailer chassis and other transportation products that are stronger, lighter and safer. That's why we call it performance steel.

www.strenx.com

Explore the world
of Strenx®

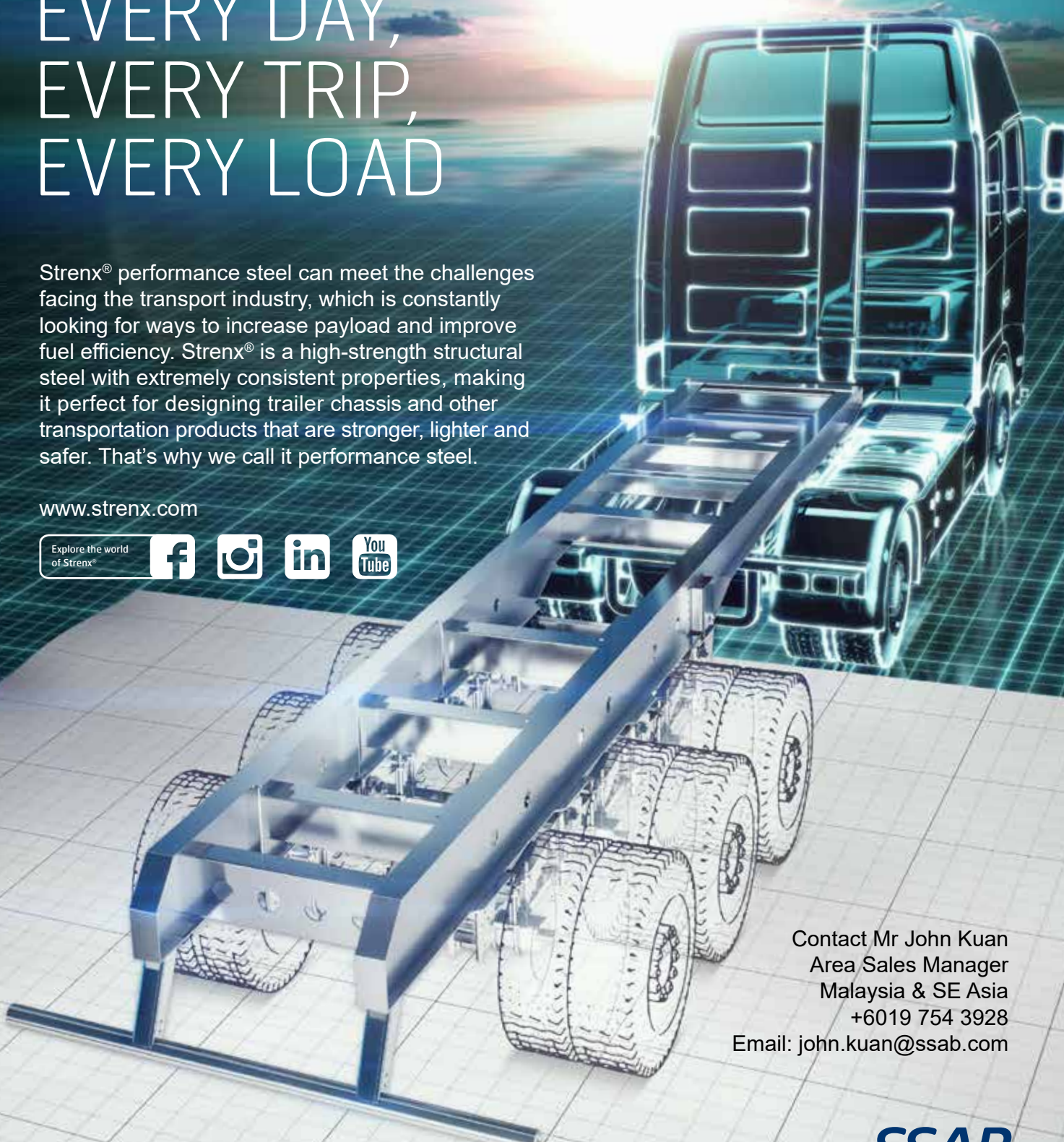

Contact Mr John Kuan
Area Sales Manager
Malaysia & SE Asia
+6019 754 3928
Email: john.kuan@ssab.com

SSAB

LOWEST INTEREST RATE IN TOWN!

**SAVE UP TO
RM 6300**



**HELP YOU
TO SAVE
MORE!**

In partnership with:



* Promotion ends 30th September 2020. Terms & conditions apply.

☎ 03 8082 9160

✉ sales@fuso.my

🌐 www.fuso.my

📘 Fuso Malaysia

DRIVING YOUR BUSINESS



MITSUBISHI FUSO authorized distributor

**HAP SENG
TRUCKS DISTRIBUTION**