

ASIAN TRUCKER

www.asiantrucker.com

MALAYSIA



TYRE TECH

Trailer Tyres

THOUGHT LEADERS

Smart Trucker Programme

Volvo Trucks. Driving Progress

SPECIAL REPORT

Trust in MAN: LTS Group takes delivery of 70 trucks

MARKET UPDATE

New President for Association of Malaysian Hauliers

FEATURE STORY

Linfox buys new trucks to support gas giant

COVER STORY:

Trucks in a quarry

ISSN 2180-382X



9 772 180 382 009 1
KDN PP16830/05/2013 (032104)



HAMMAR

THE ULTIMATE SIDELOADER

When you want the ultimate sideloader, there is only one choice- HAMMAR.

It can load and cart a 20', 2x20's, a 40', or even a jumbo 45' container in minutes at the push of a button.

Make HAMMAR your ultimate choice.

- Lightest tare weight in the world! From 2,000Kgs to 3,000Kgs lighter than the competition. Fuel savings with every kilometer covered!
- 1 tonne to 36 tonnes payload, same cycle time of 3.5 mins! Does not slow down when payload increases.
- 100% Spares always in stock.
- 24hrs back-up service, 365 days all year round.
- PTO or 84Hp Engine Power Pack options

Hammar Maskin (M) Sdn Bhd
 41, Lebu Sultan Mohamed 1/KU18,
 Taman Perindustrian Bandar Sultan Suleiman,
 42000 Port Klang, Selangor D.E.Malaysia
 Tel: +60-3-31790830 Fax: +60-3-31790831
 E-mail info@hammar.com.my
 Website www.hammar.com.my

Hammar Maskin AB
 Buagårde 35, SE-517 95 OLSFORS,
 Sweden
 Tel: +46-33 290000 Fax: +46-33 290001
 E-mail info@hammar.eu
 Website www.hammar.eu

Hammar Lift, Inc.
 300 25 Alicia Pkwy # 114 ,Laguna Niguel ,CA 92 677
 Tel: +1 (949) 716-2513 Fax: +1 (949) 716-2514
 Cell: (949) 293-0028
 Email: info@hammarlift.com
 Website www.hammarlift.com



Hammar New Zealand Ltd
 PO Box 72-1347, Papakura 2244, 3 Glasgow Ave,
 Manukau 2104, AUCKLAND, New Zealand
 Tel: +64-9 488 99 80 Fax: +64-9 488 99 84
 E-mail info@hammar.co.nz
 Website www.hammar.co.nz

Hammar Australia Pty Ltd
 PO Box W131, West Pennant Hills, SYDNEY,
 NSW 2125, Australia
 Tel: +61-2 4577 7700 Fax: +61-2 4577 7711
 E-mail info@hammar.com.au
 Website www.hammar.com.au



ASSURANCE YOU CAN

HINO TOTAL SUPPORT YOU CAN DEPEND ON EVERYTIME



FACILITIES AT OUR HINO TOTAL SUPPORT CUSTOMER CENTRE

Safety & Eco-cien
Driver Training
(1km Training Track Facility)

Driver Familiarization
Training

CUSTOMERS BENEFITS

REDUCE

Vehicle's fuel consumption

Vehicle's maintenance costs

Risk of accidents

IMPROVE

Company operational costs & revenues

Environmental performance



HINO MOTORS SALES (MALAYSIA) SDN BHD (187863-U)

Head Office, Selangor: Lot PT. 24, Jalan 223, Section 51A, 46100 Petaling Jaya, Selangor Darul Ehsan, Malaysia. Tel: (603) 7957 5199 (12 lines) Fax: (603) 7954 3276

Branch, Sarawak: Lot 1076, Block 218, 4th Mile, Penrissen Road, 93250 Kuching, Sarawak, Malaysia. Tel: (082) 451 611 (5 lines) Fax: (082) 451 993

Regional Office, Sabah: Mile 4 ½, Tuaran Road, Lot No. 353, Taman Cempaka, Likas, 88450 Kota Kinabalu, Sabah, Malaysia. Tel: (088) 393 663 Fax: (088) 424 223

AUTHORISED DEALERS: ■ **KEDAH** • AWS Jaya Motors 04-731 9706 (Alor Setar), AWS Jaya Motors 04-423 1600 (Sg. Petani). ■ **PULAU PINANG** • AWS Jaya Motors 04-398 7600 (Seberang Perai), AWS Jaya Motors 04-646 3800 (Bayan Lepas), PM Trucks 04-552 3762 (Bukit Mertajam), Sammit Motors Malaysia 04-502 1458 (Bukit Mertajam), Daihatsu Malaysia 04-397 2151 (Butterworth). ■ **PERAK** • Merge Summit 05-506 2281 (Ipoh), Daihatsu Malaysia 05-506 0178 (Ipoh), SR Automobile Centre 05-434 6000 (Bidor), Merge Summit 05-621 8971 (Teluk Intan), TTJ Agency 05-847 9368 (Taiping). ■ **WILAYAH PERSEKUTUAN, KUALA LUMPUR** • Thim Agencies (Selangor) Sdn Bhd 03-9130 8252 (Cheras), International Auto Enterprise 03-9080 4070 (Cheras Jaya). ■ **SELANGOR** • Hong Yep Motor 03-6186 3533 (Batu Caves), Eng Kee Commercial Enterprise 03-3374 9278 (Port Klang), Soo Chuan Motor Credit 03-3291 1770 (Jalan Kapar), Daihatsu Malaysia 03-5510 9988 (Shah Alam), Power Truck & Parts 03-8062 6882 (Puchong), Daihatsu Malaysia 03-8943 7235 (Serdang Raya), Daihatsu Malaysia 03-6276 3418 (Kepong), Premium Truck 03-8723 8833 (Kajang), Soon Heng Motors & Commercial Truck 03-3345 2830 (Jenjarom), SR Automobile Centre 03-6021 6007 (Bukit Beruntung), Awesome Trucks Enterprise 03-6091 6212 (Rawang). ■ **NEGERI SEMBILAN** • Soon Seng Truck & Parts 06-799 5975 (Nilai), Sembillion Motors 06-454 9999 (Bahau).

www.hino.com.my

Count On



**Test Track and
Safety Facility Provider**

**MAKE AN APPOINTMENT
WITH US NOW!**



03-7957 5199



enquiry@hino.com.my

Please browse our website to find your nearest authorised dealer



**24 HOURS
BREAKDOWN SERVICE
FOR TRUCKS**

Applicable to West Malaysia

Toll Free: **1800-88-3666**

*Terms and Conditions Apply

■ **MELAKA** • Paramount Value 06-283 2925 (Melaka), Sam Hin Motors Enterprise 06-337 6939 (Melaka), ■ **JOHOR** • Auto Skyline 07-358 5805 (Johor Bahru), Daihatsu Malaysia 07-224 6601 (Johor Bahru), Key Power 07-236 5188 (Pasir Gudang), Sin Soon Hup 07-557 5533 (Skudai), Smart Edition Auto 07-663 2628 (Kulai), Sam Hin Motors Enterprise 07-931 7939 (Segamat), Daihatsu Malaysia 07-431 5910 (Batu Pahat), Sin Soon Hup Services 06-975 6688 (Muar), ■ **PAHANG** • Edaran Riz 09-558 1200 (Kuantan), Teck Lee Motors Agency 09-296 1558 (Temerloh), ■ **TERENGGANU** • Marsing Industries Sdn. Bhd. 09-6311 022, ■ **KELANTAN** • K&T Engineering & Trading 09-765 7166 (Kota Bharu), Soon Seng Motors Enterprise 09-748 6837 (Kota Bharu), ■ **SABAH** • Angkatan Hebat Motor 088-389 262 (Kota Kinabalu), Daihatsu Malaysia 088-381 112 (Kota Kinabalu), FF Automobile 088-386 852 (Kota Kinabalu-Mengatal), Weemaju 089-666 222 (Sandakan), Weemaju 089-881 323 (Lahad Datu), Edaran ATSB 089-749 829 (Tawau), ■ **SARAWAK** • Jong Seng 082-330 066 (Kuching), Lu & Sons Engineering 082-453 737 (Kuching), Rhino Automobile 082-349 587 (Kuching), Lu & Sons Engineering 084-319 373 (Sibu), Jong Seng 086-327 866 (Bintulu), Lu & Sons Engineering 086-334 834 (Bintulu), Jong Seng 085-661 166 (Mir).

AIM FOR CUSTOMER TRUST AND CONFIDENCE



CAMC Heavy-duty Truck, European Standards Definition of new criteria for heavy-duty truck

CAMC new generation heavy-duty trucks are developed by Anhui Hualing Automobile Co. Ltd. by applying world advanced heavy-duty truck technology.

It is powered by high performance common-rail engine with low fuel consumption and high power, complying with Euro III emission standard.

Prime Mover 4x2, 6x2, 6x4



CAMC

DA DEAUTO INDUSTRIES SDN BHD (881055-M)

4x2
6x2
6x4

**PRIME
MOVER**



Engine
Hino P11C-350Hp
Hino P11C-380Hp
Cummins ISMe
420-30-420Hp

Transmission
ZF Friedrichshafen
AG. 9/16 speed

Chassis
Double Layer

Rear Axle
Hub Reduction

6x4
8x4

**MIXER
TRUCK**



Engine
Hino P11C-350Hp
Hino P11C-380Hp

Transmission
ZF Friedrichshafen
AG.

Chassis
Double Layer

Rear Axle
Hub Reduction

4x2
6x2
6x4
8x2
8x4

**RIGID
TRUCK**



Engine
Hino P11C-350Hp
Hino P11C-380Hp
Cummins ISMe
420-30-420Hp

Transmission
ZF Friedrichshafen
AG. 9/16 speed

Chassis
Double Layer

Rear Axle
Hub Reduction



A HYUNDAI LICENSED PRODUCT

GET REWARDED WHEN YOU CHOOSE INOKOM SERVICE



Up to

20% off

selected parts**

10% off

labour charges**

FREE 18

point inspection**

**ENJOY
FREE GIFTS**

with every service!

AUTHORISED DEALERS:

• **SELANGOR** • PTM Automotive Sdn. Bhd. (576172-H) 03-6188 6162 • International Auto Enterprise Sdn. Bhd. (27845-M) 03-9080 4070 • LB Truck & Tractors (922221-M) 03-3216 4113 • Song Heng Motor & Commercial Truck Sdn. Bhd. (666447-D) 03-3342 6322 • Advant Speed Services Sdn. Bhd. (717064-T) 03-8061 0625 • Sen Kuan Huat (M) Sdn. Bhd. (229291-A) 03-3269 2398 • Kembara Suci Sdn. Bhd. (714790-A) 03-8927 4322 • L&G Care Auto Sdn. Bhd. (871620-K) 03-3166 3043 • Kim Yeow Auto Service (1891192-A) 03-8736 0993 • Sime Darby Auto Hyundai Sdn. Bhd. (222391-P) 03-5102 4627 • **KUALA LUMPUR** • Avantegarde Automotive Sdn. Bhd. (860678-W) 03-9172 3299 • **PERAK** • Vong Auto Service Centre (IP0219311-P) 05-282 3232 • Tiong Hin Motors (864808-T) 05-254 8802 • Swee Huat Auto Sdn. Bhd. (836338-A) 05-847 6798 • **PULAU PINANG** • Kumpulan Edaran Otomobil MTH (M) Sdn. Bhd. (337957-D) 04-537 9426 • Huan Sin Cycle Motor Sdn. Bhd. (320385-M) 04-626 6342 • Up Service Automotive (M) Sdn. Bhd. (711678-P) 04-399 2618 • Sime Darby Auto Hyundai Sdn. Bhd. (198250-U) 04-399 7788 • **KEDAH** • Koay Eng Chong (424074-K) 04-658 8139 • BZ Auto Service Center Sdn. Bhd. (557889-A) 04-731 5204 • Maba Motor (AS0168298-V) 04-759 6119 • Lee Cheng Motor Services Sdn. Bhd. (71162-D) 04-421 3829 • **NEGERI SEMBILAN** • Ultra Gallant Sdn. Bhd. (473507-A) 06-677 9908 • Sembillion Motors Sdn. Bhd. (40522-W) 06-764 6666 • **MELAKA** • Lick Huat Motor (JM0171829-D) 06-336 2978 • **JOHOR** • Ang Trading & Motor Credit Sdn. Bhd. (30303-U) 06-955 5525 • Jaidon Motor Sdn. Bhd. (306225-A) 07-598 4894 • Jiayi Auto Tuning Centre (JM0109405-X) 07-772 5768 • Sime Darby Auto Hyundai Sdn. Bhd. (198250-U) 07-234 0714 • **PAHANG** • Syarikat Perniagaan Sri Semantan Sdn. Bhd. (81473-X) 09-296 3288 • Syarikat United Motor Supply (270573-H) 09-277 1258 • Hup Hing Motor Workshop (150747-U) 09-536 6968 • MK Autoworld Service Centre (2055140-A) 012-960 9005 • **TERENGGANU** • Regency Auto Parts & Services Sdn. Bhd. (550185-H) 09-616 1650 • **KELANTAN** • Leang Seng Motors (1980) Sdn. Bhd. (60377-T) 09-748 1351 • Baihaki Auto Service (KT0216270-K) 09-773 5799 • **SABAH** • Rightpower Autocare Sdn. Bhd. (182190-X) 088-702 288 • Terajasa Automobile Sdn. Bhd. (476428-T) 089-222 555 • Sum Hoe Automotive Engineering Sdn. Bhd. (1080616-D) 089-913 349 • Sime Darby Auto Hyundai Sdn. Bhd. (198250-U) 088-434 388 • **SARAWAK** • Regas Motors Sdn. Bhd. (72492-P) 082-571 333

Don't miss out on a fantastic opportunity to service your Inokom truck at any Inokom Sales and Service Centre from 25 January to 25 April 2016.



Call the nearest Authorised Service dealer to make an appointment.

* While stocks last.

** Terms and conditions apply.



HYUNDAI

NEW THINKING.
NEW POSSIBILITIES.



SHACMAN

陕 汽 重 卡

M3000

F3000

X3000



SUCCESS 品质成就未来
WITH QUALITY

EURO 3
ENGINE



Thank You 谢谢
for your support,
we will succeed
together in future.
Our commitment to you
with 18 service centers
in Malaysia.



FULLY SUPPORTED BY YONMING GROUP'S 21 BRANCHES
MALAYSIA NATIONWIDE, 24-HOUR RES-Q TEAM

DISTRIBUTED BY
SHAANXI TRUCKS SDN BHD
MEMBER OF  YONMING GROUP





Refuel less. Run more.



TAN CHONG INDUSTRIAL EQUIPMENT SDN BHD (013285-X)

Lot 3, Jalan Perusahaan Satu, 68100 Batu Caves, Selangor D.E, Malaysia.

Tel: 03-61899832. Fax: 03-61899336. Email: enquiry@tcie.com.my Website: www.tcie.com.my

Branches: • Batu Caves Tel: 03-61891896 • Ipoh Tel: 05-2921028 • Johor Bahru Tel: 07-3530300

Free driver training paired with our real-time coaching system will help you achieve safer and best fuel economy for each trip.

Find out more on our Quester products at the UD Trucks dealer near you



TCTS Branches: • Bukit Mertajam Tel: 04-5381308 • Kajang Tel: 03-87410537 • Ipoh Tel :05-2923018 • Johor Bahru Tel: 07-3584300 • Batu Pahat Tel: 07-4131833 • Malacca Tel : 06-3366957 • Muar Tel : 06-9531300 • Klang Tel: 03-31669609 • Sri Gombak Tel : 03-61850854.

East Malaysia Branches: • Sabah Tel: 088-499228 • Sarawak Tel: 082-488811.

Authorised Dealers: • Combine Motor Sdn Bhd Tel: 03-61363060 • MHK Auto Commercial Sdn Bhd Tel: 03-62587777 • Taycn Kredit Sdn Bhd Tel: 06-6787760 • Commercial Junction (M) Sdn Bhd Tel: 07-4333998 • Minufa Automobile Sdn Bhd Tel: 09-5676363 • LK Utara Auto Sdn Bhd Tel: 04-7339098



34



32



30

CONTENTS

22 EDITOR'S NOTES

MARKET UPDATE

- 24 Asdion adds Auman trucks for growth
- 26 Taipanco's Nazari new president of Association of Malaysian Hauliers
- 30 Ah Sang Motor Workshop adds capacity to straighten frames
- 32 Volvo opens Flagship Workshop

COVER STORY

- 34 Boulders. Dust. Trucks in a quarry!

SERVICE

- 40 Scania Asian Parts Centre Improves Regional Service

11 DEALERSHIPS. NOW A FLAGSHIP. PORT KLANG.



4 OPENING PROMOTIONS UP FOR GRABS! TERMS AND CONDITIONS APPLY.

Package 1: Receive a **50% off Volvo Genuine Parts voucher** with every purchase of a Preventive Check package. Comes with FREE smoke test, brake test and truck wash worth RM 250.

Package 2, 3 and 4: Save up to 60% when you purchase Volvo Genuine Service packages, Brake pads/ lining packages and Drive Belt packages.

From now until 31 March 2016.

Volvo Malaysia Sdn Bhd (Port Klang)

39, Lebuhr Sultan Mohamed/KU18,
Taman Perindustrian Bandar Sultan Suleiman,
42000 Pelabuhan Klang, Selangor Darul Ehsan
Tel: 03-33754200 Fax: 03-33754203

For more information, please visit www.volvotrucks.com.my

Volvo Trucks. Driving Progress





CONTENTS

SPECIAL REPORT

42 Trust in MAN: LTS Group takes delivery of 70 trucks

FEATURE STORY

46 Linfox buys new trucks to support gas giant

THOUGHT LEADERS

50 PKT Logistics Smart Trucker Program addresses driver shortage

TYRE TECH

54 Continental talks about Trailer Tyres

INNOVATIONS

56 Introducing APPs into logistics

58 JA Security and Innovations gives shippers peace of mind

LOWERING OPERATION COSTS TODAY COULD MAKE YOUR MARGINS GO FURTHER TOMORROW.



We know more efficiencies means more business growth. That's why we've formulated Shell Rimula Synthetic heavy-duty diesel engine oils. It helps to contribute to long oil drains, long engine life and improved fuel economy* to help lower the total cost of ownership. You do everything you can to make your business run better. We aim to help you do a little more.

*Compared with a typical 10W-40 oil over a 100,000km oil drain interval.

Find out more at www.shell.com.my/realdestinations

THE ENGINE OIL THAT WORKS AS HARD AS YOU.



Shell
RIMULA

66



68

CONTENTS

TECH TALK

60 Actively tracking

SAFE ROADS

64 The way to make our roads safer is to change people's behaviour

THE RALLY

66 Iveco Triumphs at Hotly Contested 2016 Dakar Rally

THE FEMALE SIDE

68 Who is that woman behind this truck workshop?

TRAFFIC FLOW

70 Controlled traffic runs smoother



My job: fleet manager. My choice: LuK clutches.

Choose the highest performance clutch system.

Up to 30 %
increased
wear
resistance!



We have redefined longevity.

Our new heavy duty friction lining has a lot to offer! With the new material compound we have achieved an increase of up to 30 % in wear resistance and this with premium comfort characteristics. Not only does that sound good, but is unique in the market.

What you can expect:

- Longer service life
- Less downtime
- More efficiency
- Lower costs

This is our offer for your efficiency.

More garage knowledge: www.rexpert.com

For more information, please contact:

Schaeffler Bearings (Malaysia) Sdn. Bhd.

Tel: +603 6275 0620 ext 122

Fax: +603 6275 6421

Email: LuK-AS.sg@schaeffler.com

www.schaeffler-aftermarket.com



SCHAEFFLER
AUTOMOTIVE AFTERMARKET



CONTENTS

72 ASIAN TRUCKER DRIVERS CLUB UPDATE

74 TRUCKER OF THE MONTH

TRUCK FEATURE

78 Bringing back Memories - Isuzu celebrates 100 years

80 NEWS & NOTES

84 IN THE HEADLIGHTS

CRAFT YOUR FUEL CARD TO THE SIZE OF YOUR FLEET

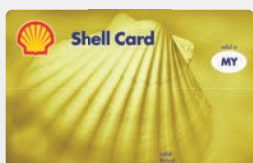

YOUR PARTNER
ON THE ROAD

Please contact us at:

1 300 22 8181

www.shell.com.my

- **CONTROL**
- **CONVENIENCE**
- **SECURITY**
- **SAVINGS**



The Drivers.

**ASIAN
TRUCKER**

EDITORIAL

Editor

Stefan Pertz

Writer

Fajar

Graphic Designer

Eng Chuan

Photographers

Floyd Cowan
Eng Chuan

Contributors

Floyd Cowan
Peter Burns, FleetSafe

Advertising

Nicole Fong
Nicole@asiantrucker.com

SINGAPORE

Floyd Cowan
Floyd@asiantrucker.com

THAILAND

Songyot Kamontavikun
Songyot@asiantrucker.com

ASIAN TRUCKER DRIVERS CLUB

Sponsorship / Membership
info@asiantruckerclub.com.my

CIRCULATION, CONTRIBUTIONS and SUBSCRIPTION

info@asiantrucker.com
WEBSITE and E-NEWSLETTER
www.asiantrucker.com

PUBLISHED BY

Asian Trucker Media Sdn. Bhd.
Empire Tower
A-5-9
SS16/1
Subang Jaya
47500, Selangor
Malaysia

www.asiantrucker.com

ARTICLES

Asian Trucker is a registered trademark of Asian Trucker Media Sdn. Bhd. All articles submitted for publication become the property of the publisher. The editor reserves the right to adjust any article to confirm with the magazine format.

Asian Trucker is a bi-monthly publication. The publisher will not be responsible for any copyright violation of articles that have been approved by contributing writers. The publisher accepts no responsibility for unsolicited manuscripts, illustrations or photographs.

PRINTED IN MALAYSIA

Percetakan Osacar Sdn Bhd
(Co.Registration : 63461-W)
Lot 37659, No 11, Jalan 4/37A,
Taman Bukit Maluri Industrial Area
Kepong, 52100 Kuala Lumpur

Distributed by

MPH Distributors Sdn Bhd (5048-A)
Ground Floor Warehouse, Bangunan TH
No 5, Jalan Bersatu Section 13/4
46200 Petaling Jaya
Selangor Darul Ehsan Malaysia

**Boost your business with a listing on our new website.
Find businesses or sell your truck, upload your events or images to the gallery.
Visit our new website www.asiantrucker.com to put your company on speed.**

The Volvo Trucks Malaysia insert contained in this issue of Asian Trucker is a supplement to the magazine and is free of charge to our readers.



You Can Count on MAN

High Powered. Low TCO. With MAN TGS.

Be it for challenging road conditions or tough economic climate, you can count on MAN. With MAN trucks, you get high performance coupled with low total cost of ownership

The perfect combination for the toughest of transportation tasks.

MAN Truck & Bus (M) Sdn. Bhd. (224536-W)
Lot 4, Jalan Industri 3/2,
Taman Industri Integrasi Rawang,
48000 Rawang,
Selangor Darul Ehsan.

T • 603-6092 6977 F • 603-6092 6966 W • www.man.com.my

MAN kann.





stefan@asiantrucker.com

New Year with New Energy

We left 2015 behind and with it, it seems, a lot of worries and old cobwebs. The new year starts fresh, in many ways. We are seeing a new president of the Association of Malaysian Hauliers, new trucks being delivered in large numbers and workshops being opened. We also kicked off 2016 with a workshop on tyre safety that saw a new record number of participants. There is also a range of new products that have been launched and are now making the lives of truckers easier. All of this you will find in detail in this issue of Asian Trucker, our first for this year.

It is also a year of celebrations as Isuzu turns 100, MANN + HUMMEL 75 and the IAA will return to Hannover, Germany in September. Besides that, we will see our Asian Trucker Networking Night taking place again. This, to me, is going to be the highlight of the year as it allows me to meet a lot of industry leaders in one evening, hearing what they have to say. On that note, we would encourage you also to let us know what you think of our magazine and the articles we write. We recently had a comment from a reader, who was very surprised when I called to find out more about his feedback. We are obviously striving to make this magazine the best source of information for the industry, but can't do that without you.

One of the issues that the industry is still lamenting is the lack of drivers. I asked this before and maybe it is time to pose the question again: is the industry doing enough to advertise itself? At the same time, I also have to ask if drivers are doing enough to portray the right image. When you see comments on Facebook about risky driving behaviour or the way drivers act, it may not be a wonder that mom and dad don't want their kids to be stigmatised. I am not saying that truckers should all wear suits, but when I see the guys hanging off the back of a garbage truck with no gloves and only wearing flip flops as their footwear, I am also puzzled as to why they don't claim their right to proper equipment. I encourage you to meet the Smart Truckers at PKT, who radiate a pride for being truckers that I haven't seen rivalled yet. I am very happy to see this new breed of drivers growing up. I recently also saw a few items on truckers on the mainstream media. These educated people on how to better understand the truckers and the way a big rig works and manoeuvres. This made me very happy as it showed people in our industry in a positive light. Hopefully we can all produce more such articles for the media to run.

One thought occurred to me while driving to the Tyre Safety Workshop on Saturday: with driverless trucks, will there be hackers that crack the code to re-program vehicles to be hijacked remotely? There is a whole new world ahead of us.

Drive safe and I see you soon!

Stefan Pertz

Editor, Asian Trucker Malaysia

SCANIA

1 8 9 1 - 2 0 1 6

125 YEARS



Driving your profitability through sustainable solutions.

For 125 years, the heart and soul of Scania has come from the ingenious minds behind the scene, creating industry solutions that will continue to optimise your operations for the best profitability for the next 125 years and more.

Trucks

Able to handle long-haulage, distribution, construction and special purposes, our robust and fuel-efficient trucks cover your every need.

City Buses and Complete Coaches

Our dedication to passenger comfort and safety makes every city or intercity journey an enjoyable one with our reliable and fuel-efficient chassis and complete bus solutions.

Marine, Industrial and Power Generation Engines

Features powerful technology and flexible customer options to power up your business.

Services

We are located in 10 Scania owned and operated service centres across Malaysia, providing scheduled maintenance, parts services, contracted services, connected services – Vehicle Introduction, Driver Training, Driver Coaching, Driver Support, Scania Fleet Management, and Scania Assistance 1800-08-8500 for maximum uptime. No matter the time, location or need, our service teams are accessible 24/7, even for difficult-to-reach areas.

Scania Credit

Value and flexibility of the diversified financial solutions to insurance with your profitability in mind.

Call +60 3 7845 1000, email us at smyenquiries@scania.com, follow us on Scania Malaysia Facebook or visit our website for more information.



www.scania.com.my

Scania (Malaysia) Sdn Bhd (518606-D) No.1 Jalan Tiang U8/93, Bukit Jelutong Industrial Park, 40150 Shah Alam, Selangor D.E. Malaysia

Scania pursues an active policy of product development and improvement. For this reason the company reserves the right to change specifications without prior notice. Furthermore, due to national and legal requirements, some accessories may not be available in local markets. For further information in these respects, please contact your local dealer or visit www.scania.com

Asdion adds Auman trucks for growth



Receiving the first five of a total 30 Auman trucks, Asdion adds capacity to their business as the company is expecting significant growth for the year 2016.

Citing an already good relationship between Asdion and Tan Chong Group, Ybhg Dato Sri Maglin Dennis D’Cruz, Chairman of Asdion Bhd said during the hand-over of the first five trucks “This is another milestone for the two companies. This year has been a very challenging one, but the purchase of these trucks is a sign of our dedication. And we are dedicated to our clients, partners and shareholders.” According to him, Asdion, as a listed company, would now be ready for further expansion, which had started in 2015. All of the 30 trucks are meant to add capacity to the existing fleet as they are additional and not to replace older trucks. The completion of the delivery is scheduled to be end of January.

“We have a good product. One that is offering quality for the money,” said Danny Ng Kiat Seng, Senior General Manager of Angka-Tan Motors Sdn. Bhd. Handing over the first batch of trucks on Saturday, 5th of December, the order constitutes the largest single order of Auman trucks so far. The dump trucks purchased by Asdion are locally assembled CKD kits with custom made buckets. Some modifications have been carried out to ensure that the tipping mechanism meets the needs of the client. Configured as 6x4 chassis with 330 HP Euro 2 engines, the vehicles come with 2-Year warranty. What is special is that there is unlimited mileage covered instead of the common 100 000 KM during the warranty period. Once commissioned to work, the Aumans will be used to transport dry bulk products. In his speech, Ng also stressed the fact that the company has made a significant effort to improve customer service and is now stocking some seven million Ringgit worth of spare parts in order to ensure that parts are available at any time.

Also present at the hand-over ceremony was Mr. Jason Minos, Executive Director of Asdion. He explained that the company had previously purchased 10 Auman trucks. These are used for haulage duties in Kuantan’s port and have convinced the client. “These trucks came highly recommended. We have found that the trucks we already have perform well and thus we continue to buy Auman” Minos stated. A further confidence boost was the availability of spare parts as Minos says that this was one of the key issues for the operation. As the trucks are going to be used in mixed, on and off-road conditions, they will be put to the test when transporting palm oil kernels or iron ore. This order will take to total number of trucks currently in the Asdion fleet from 40 to 70, with the majority (40) being Auman trucks. **T**





Mercedes-Benz Actros provides you with the

Unlimited Mileage* or 2 Years Warranty**

Terms and conditions apply.

For more information, please visit your nearest authorized dealership.

- * For overall vehicle: This warranty covers a period of twelve (12) months inclusive of factory warranty period with unlimited mileage starting from the vehicle registration date of first delivery.
- ** For powertrain (engine, transmission and axle): This warranty covers a period of twenty-four (24) months with unlimited mileage in the first year of operation of mileage. However, the warranty will expire after the vehicle has covered a total of 200,000 kilometers in the second year of vehicle operation starting from the vehicle registration date of first delivery.

Mercedes-Benz

Trucks you can trust



Mercedes-Benz Malaysia Sdn Bhd (596096-H)
48th Floor, Menara TM, Jalan Pantai Bahru, 50672 Kuala Lumpur.
Tel: 603-2246 8888 Fax: 603-2246 8899 www.mercedes-benz.com.my

CUSTOMERCARE
CENTRE
1-800-88-1133

Taipanco's Nazari new president of Association of Malaysian Hauliers

Stefan Pertz met with Nazari Hj Akhbar, newly elected president of the Association of Malaysian Hauliers a mere 48 hours after his first committee meeting where the organisation charted a new and ambitious way forward.

Having been elected as President of the association for two years on December 9th 2015, Nazari vows to "Address major issues while we also elevate the profile of the Association of Malaysian Hauliers, known as AMH". Having been in the industry for many years, he is known to be heading Taipanco, one of the country's leading haulage companies. In their first committee meeting on 15th January, several crucial points were discussed.

As per IMP3, more than 90% of the international trade is seaborne, which seaports provide the crucial interface between shipping and land transport. From the seaborne perspective, during the IMP3 period, the share of containerized cargo to the total throughput is projected to increase from 139.2 million tons,

or 55.1% in 2005 to 441 million tons (58.7%) in 2020 (chapter 25,IMP3).

As the inland container hauliers are an integral element of the seaborne movement of containerized cargoes, the role of the inland container haulier are vital to the nation's industrial development.

Improving Depots

According to him, several depots are not performing to the expectation and satisfaction of the members. In the case of Westport, a Memorandum was signed years ago, stipulating guaranteed loading times, opening times and penalties in case the truckers had to wait longer than the promised times. Some depots manage loading times of only 45 minutes, while others take as long as three hours to have the containers ready. Another issue is that the practice and standards for hauliers in different regions vary and not the same. Harmonization is required to ensure smoother dealings between the parties involved.

SPAD to the Task

One pressing issue AMH sees is the issuance of permit for transporters.

"There is no official number available as to how many licences have been issued," Nazari explains. The association sees an increased competition that is purely price based. "Undercutting is unhealthy for our industry. There are new players that try to get any job at cut throat cost" he stated. This, as the association believes, is leading to a dangerous situation, whereby the service cannot be in a satisfactory and more importantly safe way. AMH would like to understand how many licences are out there in order to assess if there is already an overcapacity which may not be healthy.

Driver Shortage

Lamented by many, there is a severe shortage of drivers in Malaysia. The association seeks to address the question as to what it takes to attract more people to this industry. Poaching of good drivers is now rampant, but not good for the industry. Members of AMH are worried, that this situation is not sustainable. As a result, drivers may now also become more demanding to the point where their requests are adding extra stress to the company.

Infrastructure

While some roads seem to rival the German Autobahn, others are in a sorry state. "Look at the road leading to the airports. Fantastic! But then you see the highways and roads leading into many of our ports and they are not only uncomfortable to drive, but also





Picture for illustration only*

Your ride to business success. From Vito to Actros, Cycle & Carriage Bintang has it all.

Every commercial vehicle that bears a Mercedes-Benz star means quality, outstanding reliability, economy and exemplary safety. In Cycle & Carriage Bintang, we offer even more:

- Biggest on-call network from Bukit Tengah, Penang to Johor Bahru, Johor
- Most experienced in providing business support
- Fully committed to provide the best Mercedes-Benz service
- Service 24H Mobile Team
- 24 Months Mercedes-Benz Genuine Parts Warranty*

Visit your nearest Cycle & Carriage Bintang Autohaus for more information.

*Terms & conditions apply.

Mercedes-Benz
Truck you can trust.



www.ccb.mercedes-benz.com.my

Cycle & Carriage Bintang Bhd (7378-D) (Batu Caves)
Tel: 03-6192 9200
24HR Breakdown Service: 019-353 7735

Cycle & Carriage Bintang (Perak) Sdn Bhd (1554-H) (Ipoh)
Tel: 05-5064266
24HR Breakdown Service: 019-573 3180

Cycle & Carriage Bintang (Northern) Sdn Bhd (114255-P) (Bukit Tengah)
Tel: 04-507 2966
24HR Breakdown Service: 019-481 7217

Cycle & Carriage Bintang Bhd (7378-D) (Johor Bahru)
Tel: 07-238 2299
24HR Breakdown Service: 019-266 3282

dangerous in places,” voices Nazari. These roads are the arteries of the economy and should be better taken care of in the view of AMH as it would benefit many besides the members and other truckers.

Other Issues

During the committee meeting other issues with JPJ and Puspakom were also identified and tabled to be handled. These are on-going issues that will need further dialogues and the solutions may take a while to implement as there are many things to be considered. One of the issues that needs to be addressed is the implementation times given by JPJ at times. While AMH acknowledges that many new directives, rules, regulations and laws are indeed helping to improve the industry, implementation may be difficult as the stipulated times may require to call back entire fleets across the country, thus stopping operations.

Internal Matters

The Association has also taken a critical look at their own ways and several points were noted as to how to take it to the next level. Nazari acknowledged that in the past there has been a lack of communication to the members. The website needs to be updated and overall, more activities are required. The website could actually become a portal that lists spare parts dealers and others. “We need more support from our members. But we can only get that if we give back to them,” is his claim. When it comes to certain actions, AMH may now be a bit more forceful. For instance when the AMH decided to take certain action, it requires the collaboration of all members, not just a few.

Asian Trucker would like to congratulate Nazari Hj Akhbar to his new post as the President of Association of Malaysian Hauliers and is looking forward to seeing the members move forward in the pursuit of improving the industry. **T**



Lift your business with
Cranes & Hookloaders
from HYVA!

HYVA LIFT

HYVA CRANE



Hyva (Malaysia) Sdn Bhd lot 21, Jalan 4/32A, Kepong Industrial Estate Batu 6.5, 52100 Kepong.
Kuala Lumpur, Malaysia. Tel.: +603-62573319 Fax: +603-62597475 sales@hyva.com.my

www.hyva.com



Ah Sang Motor Workshop adds capacity to straighten frames

Already known all over Malaysia for their ability to fix truck chassis and trailers, Ah Sang Motor Workshop adds another Josam alignment set to improve service and to add capacity.

Run by three brothers, Ah Sang Workshop recently opened another workshop just up the road from their established premises in Shah Alam. Designed to handle more truck repairs, especially the alignment of truck frames, both garages are equipped with Josam tools to straighten truck chassis and trailers. "We started in a small workshop in Kepong in 1974", said Fred Chen, Director of Ah Sang Workshop Sdn. Bhd. His brother, S.P. Chen adds that "The current place has been in operation for over a decade now. There are now some 100 staff to handle the work and we receive trucks from all states of Peninsular Malaysia". The workshop deals with insurance claims, assesses those and repairs the trucks, but also services and repairs trailers.

S.P. Chen stated that Ah Sang Workshop was actually a pioneer, starting to use Josam equipment very early and may well be the first to purchase the equipment. "Our staff knows the equipment very well. When we purchased the second set, the Swedish technicians were done with the training in no time," he adds. According to him, there are many advantages in using Josam equipment. For starters, the traditional methods are

not as precise as the laser guided frame presses from Sweden. Furthermore, the actual work is very time and labour intensive when using wooden frames to re-align a chassis. All this adds to the productivity and efficiency of the workshop handling the repairs. "But that's not all. Obviously, you add an extra layer of safety to the repaired truck when you use hi-tech equipment as the process is more precise," Chen states. Besides that, the use of the Josam equipment has boosted customer confidence in their capabilities. The recently purchased Josam Jo 2000 was installed in the second workshop. Manbeni Machine Tools would be the go-to address for Josam equipment in Malaysia. Here Ah Sang Workshop had the opportunity to purpose build the workshop to suit the needs of working with the alignment tools.

Would Chen recommend straightening trucks or trailers on a regular basis even when they did not have any accidents? "Yes, and there is a good reason for it" he explains. For example, the road conditions in certain places, like construction sites, put extra stress on vehicles and trailers. Also, uneven loads may impact the frame. Even uneven wear and tear of tyres may have a negative effect on the frame. As a result, the truck and trailer may not run straight anymore. "It is a common belief that you don't have to align the frame of trailers. However, if you want to improve performance and safety, this is highly recommended," Chen states. Some cases are beyond repair, even with the highly sophisticated Josam tools. "That's when we don't carry out the work, when the safety of drivers is at risk even after we are done."

Besides the repair of trucks, Ah Sang Workshop is also painting new trucks in their premises. The workshop itself is P.I.A.M approved and supported by their in-house company dealing in spare parts. 



Their lives are in your hands
GET GRIP

Supercool G Series. Road grip experience taken to a new level.

Our new flagship cooling rubber compound uses GRIP TECHNOLOGY* to make your every ride a safer journey. It provides the ultimate stopping performance and agility. Supercool G Series is able to satisfy the most challenging demands. Simply safer, simply more gripping. Not all retreads are the same. WE TAKE SAFETY SERIOUSLY.

*Attested with Dynamic Mechanical Analysis result of Tan δ at 0°C: 0.2196

SupercoolTM
G Series

www.giibworld.com

GIIB

RUBBER



Volvo opens Flagship Workshop

Located in close proximity to one of the world's busiest ports, this workshop is ready to serve the largest population of trucks in the country, offering fast service and convenience for customers.



Following a soft-launch on December 1st 2015, the Volvo Flagship Workshop was officially opened in a grand event on January 26th 2016. The construction was completed in Q3 of 2015 after the initial plan was hatched in 2012 as part of the expansion and improvement plan that Volvo Malaysia has in place to ensure that customers will have access to a workshop nearby. According to Mats Nilsson, Managing Director, Volvo Malaysia, the brand aims at placing workshops in a way that travel to them will take less than three or even two hours. The newly opened workshop is capable of handling both buses and trucks, whereby Volvo is expecting the majority of work to be carried out on trucks while buses will be mainly handled in Shah Alam.

Able to handle some 24 trucks per day, the workshop is also offering Fast Track Service, a driver lounge, beds and showers make it a convenient stop for the drivers. Opening hours are Monday to Friday from 8:30 to 18:00 and on Saturday from 8:30 to 12:45. As part of the overall budget of 75 Million Ringgit, Volvo has invested some 25 Million Ringgit in the new facility and the upkeep over the next 10 years. The architecture follows modern workshop design. It is designed with constructed columns for double bays to allow for easy manoeuvring into and out of the workshop. An overhead crane, brake and smoke tester and a sophisticated computer system allowing technicians to assess vehicles are part of the overall set-up. "This is a sign of Volvo's commitment to the market," was one comment from a guest at the opening event. Located just next door is Taipanco, one of Malaysia's leading transporters, who was the first customer to send their truck for service. On the night of the opening, seven customers also received their trucks in a hand over ceremony.



"There is already a population of over 2 000 Volvo trucks in the Port Klang area and we are now located at the heart of it," Nilsson said. He also highlighted other achievements of Volvo in Malaysia, such as the re-certification of the Shah Alam plant according to ISO 14001, the opening of other workshops earlier in 2015 as well as the tremendous success of Fuelwatch, the competition that saw over 1 100 drivers from Malaysia and Singapore seeking the most fuel efficient driver. One of Volvo's core values is safety and that is now manifested in the aim of having zero accidents with Volvo vehicles.



Looking forward into 2016, Nilsson pointed out further enhancements of the network. "We will continue to build our network to support our customers wherever they are" he promised. 

STEELBRO

CONTAINER HANDLING SOLUTIONS

Steelbro established since 1878



SB450 sidelifter

Heavy duty for tough working environments

- ▲ 45 tonne lifting capacity
- ▲ Massive outreach for excellent stability
- ▲ Quicker, more efficient lifting of containers
- ▲ Stand alone power pack reduces running costs and adds fleet flexibility as can be used with any truck head
- ▲ Ideal for road, rail, military, forestry and mining applications

New & improved services & after sales support

- ▲ Full service workshop
- ▲ 24 x 7 Service
- ▲ New fully equipped service support vehicles
- ▲ Service plans to suit your needs
- ▲ Comprehensive parts availability
- ▲ National network of service centres



Service Centres

Malaysia
Steelbro (M) SDN BHD
+603 31 76 3833

Johor Bahru & Singapore
Roys Machinery Enterprise
+6017 746 5185

Sarawak & Sabah
Asbest Transport
+6016 8679619

Phone: +603 31 76 3833

Malaysian Head Office
STEELBRO (M) SDN BHD
Lot 2 Jalan Sultan Hishamuddin 2
Kawasan Perusahaan Selat Klang Utara,
42000 Port Klang
Selangor, Malaysia

The world's best valued sidelifter

www.steelbro.com
marketing@steelbro.com



Boulders. Dust. Trucks in a quarry!

Dynamite might be strong enough to crumble granite, but it takes a tough truck to move it from the bottom of the pit to the crusher, making the many trips a day a challenge as quarries pose a number of challenges for man and machine.





It is hot, the sun is beating down relentless. The work environment is tough, with dust, heavy loads to move and the work environment requires extra care from everyone. A quarry puts additional stress on man and machine. Asian Trucker visited the Ulu Choh quarry of Hap Seng Building Materials Sdn. Bhd. to see how trucks perform in such operation.

Situated in Johor Bahru, this quarry has been in operation for a number of years and the pit is some 130 meters deep. This does not sound like a very big distance to bridge, but we have to remember that the “roads” are literally just paths that have

been grated into the surface in order to allow the trucks to move. As the sun is rising, the pit also acts like a large frying pan with the heat cumulating in it. The heat is just one of the many issues that the team at the quarry has to deal with. All staff at this site is local and they work 12 hour shifts, rain or shine. As rain wouldn't have an impact on the product, even heavy downpours don't stop the operation. Here, Hap Seng sources granite which is crushed on site. It sounds very simple: blast the granite, break the big blocks and drive them to the giant crusher that is rattling away at the fringe of the quarry, all the way back out of the pit.

The trucks at work

Model / Configuration	: Actros 4840K / 8X4
Gross Vehicle Weight (GVW)	: 48,000 kgs
Wheelbase	: 4,500 mm
Engine	: V6, 394 HP (290 kW), Euro 2
Transmission	: Telligent Gearshift
Braking system	: Telligent braking system with ABS and ASR
Axle ratio / type	: 5.849 c/w differential lock
Others	: Driver's suspension seat, power windows, central locking

Following the success of this truck model, it will now be available as CKD version. It will come in on-road and off-road variants (designated by different model numbers).



However, it isn't that simple. The distance the trucks travel is very short. It is a steep incline, but nevertheless it is a tough terrain with sharp bends and uneven surfaces. The maximum speed any vehicle is allowed to drive in the quarry is only 15

Km/h. This also means that the trucks don't enjoy the slipstream of cooling wind as their cousins would on the highway. And when it rains it might cool down a bit, but then the paths become really slippery. It takes skills to move the trucks around as they are fully loaded on the way up and totally empty on the way down. The kinetic dynamics couldn't be any different. Peter Burns of FleetAlert said "Quarries are dangerous environments. Especially the very large open pits. Truckers drive for long times just to get from the bottom to the top, some pits have transit times of up to an hour. Some quarries are very hot. This may lead to fatigue". And it is then when the drivers risk slipping down the slopes. To counter this, some operators rely on fatigue detection systems that are being installed in the trucks.

Dust is another issue that affects man and machine. Not only during the weekly blast, when granite is being split off the surface by using explosives, but during the entire production of the aggregates a lot of dust is created. Using excavators to move the blown-off boulders into the trucks, crushing the boulders and finally loading the finer aggregates onto trucks to deliver them to the actual worksites all creates dust. This has an



impact on the filters of the trucks as well as the belts, seals and valves. Regular trips with a water truck to wet the roads is one measure taken in order to reduce the impact of fine dust.

"This is a very unforgiving work environment. It is noisy, the moving vehicles are big and you have to be aware of falling objects all the time," said the Quarry Manager on site. Although trucks don't need to be registered, they still need to be in top working condition to ensure safety. The signal for reverse, mirrors to allow the driver to see others moving about and certainly the brakes need to be in tip-top condition. "We have our own workshop here to allow for minor repairs and change of tyres. The other scheduled maintenance is done by our partner," she said. Currently, some six Fuso trucks and 3 Actros are being put to task in Ulu Choh.

For a quarry operation, two things are crucial: firstly the ability to move as much as possible per trip and secondly, the tipping speed. The latter is important as the trucks need to return to the bottom of the pit for the next load as quickly as possible. "Here the Actros have proven their value" Frankie

Chia, Regional Operation Manager - South Johor of Hap Seng Building Materials said. As the Mercedes trucks have more capacity compared to the Fuso trucks currently deployed along the Germans. Plans to add more Actros are in the pipeline while another partner also proved to be up to the challenge. The buckets of these trucks were produced by Nichi Engineering. Mr. Ron Delany, Executive Director, Quarry Division of Hap Seng said "These buckets have been a challenge as Hap Seng's strict and specific requirements for the quarry operation were truly pushing the limits somewhat. However, we are happy to say that Nichi Engineering managed to find a solution that turned out to satisfy us".

The Driver at Work

One of the drivers we met during our visit is Mr. Ahmad b Mohammad Yunos, 53. He seems to be very passionate about his job as a truck driver in a quarry. Not many people like to spend their days in the hot sun, while the job is to be performed in a hazardous and dusty environment. But this gentleman right here is keen to improve his skill in driving the Mercedes truck every day.



According to Ahmad, the skill that is most important when it comes to mastering driving a truck in a quarry is the way you handle it as you go through such route that has big and small stones everywhere: hilly, slippery roads that have sharp turns. One mistake may result in the truck and driver running off the road and tumbling down into the bottom of the pit.

"This quarry has been my playground for the past four years. The risk might be higher if comparing this to driving on an open road. Nevertheless, safety concerns in quarries are always a top priority even though you don't need a licence to drive in a quarry," said Ahmad.

"I prefer to drive in a quarry because I think my job gives me more freedom while having a fixed income and no different trip to fulfil every day. It could be an age factor where I am not willing to travel anymore and rather have a fix working place near my home," he added, smiling. 

WABCO

OE & AM Partner (Original Equipment & After Market)



VEHICLE CONTROL SYSTEMS

Your Truck Safety, Our Responsibility



DISTRIBUTED BY



WWW.YONMING.COM +603 - 6251 9448



In Q4 of 2011, Scania opened the Asian Parts Centre (APC) in Singapore to better serve the needs of the fast growing and vast market in SE Asia. Scania Parts Logistics in Oplabbeek, Belgium, is the worldwide distribution centre of all Scania parts. From there parts are shipped to regional warehouses in Europe, South Africa, Brazil, Mexico, Singapore and Indonesia. Via these hubs the Parts Centres supply their region.

Asia Focus

With a strong focus on Asia, Scania is always looking for ways to better serve its customers. In 2010 a feasibility study was conducted and the go-ahead was given in December 2010. In 10 short months Scania found suitable premises and partners to handle the logistics as well as setting up the operation and defining the stock profiles. The operation officially commenced on October 3, 2011.

"When we opened the warehouse in Bedok," relates Bjorn Gunnarsson, Manager Asian Parts Centre, "there was a shortage of warehouse space in Singapore. As the place here is close to Changi Airport it made it the logical place to be in order to serve our customers in the fastest time.

Serving the Markets

When the Asian Parts Centre opened it served and expanded to Singapore, Malaysia, Indonesia Thailand, Laos, Vietnam,

Philippines Brunei and Hong Kong. It since has calved off Indonesia, a move which has just been completed. "We found that the demand from Indonesia for parts for, particularly for the mining industry, warranted opening a parts centre there. From September 2014 to September 2015 we set up Indonesia, moving needed parts to the new warehouse there. That was a big challenge and a great deal of work," says Mr. Gunnarsson. "If demand justified it, we would open another hub in the region."

The 4 500sqm warehouse is supplied on a weekly basis via sea and airfreight. Scania has a total of 100,000 part numbers. When the Asian Parts Centre opened the operation the initial availability of parts was 90%, while the target was 95%. The APC has exceeded the target hitting 96.5%.



Scania Asian Parts Centre Improves Regional Service

Scania's Asia Parts Centre was opened in Singapore four years ago with the objective to provide quicker service for its customers. It has met the target and exceeded it.

The Parts Turn Over

Scania's Asian Part Centre operates 24/7 with about 1 000 orderlines a day that are going out as daily stock orders, emergency orders or Vehicle-Off-Road (VOR). "Three to four 40-foot containers of parts come in a week, and those parts go out as individual orders. Three to four times a year the entire stock will turn over. On-going stock taking is done throughout the year with about 1/12th of the inventory being checked a month. "We have 15 staff working here," Mr. Gunnarsson states. "We are not automated in terms of stock picking. That gives us the flexibility to add more staff when things get busy."

VOR shipments go to Australia, New Zealand, Taiwan, China and Japan. Air freight service will be added to Australia and New Zealand.

The point of opening the APC was to cut the lead times for customers receiving needed parts. The result is impressive as the lead times have now dropped drastically from four to six weeks, when the parts were being ordered from Europe, to same day delivery in Singapore, 24 hours to Malaysia and Thailand. If we get an order before 4:00pm we will have it to our customers in the region by 10:00am the next day - having done all the custom clearances."

A Reason to Chose Scania

Naturally, this is more efficient and will translate into a better vehicle up-time for the customers, in turn resulting in better efficiencies of fleets. "We want to give our customers reasons to stay with Scania, not reasons for going somewhere else."

In the warehouse Scania has done its best to keep parts to a minimum. They have done this by using the same parts through successive generations of trucks and buses.

As a strategic location, Singapore was chosen as it is a central point with highly efficient port and customs procedures. The high amount of traffic also results in low shipping cost, which again translates into lower cost for the customers. "Singapore promotes itself as a business centre. It promotes itself as being highly efficient so they make everything easy for us when we are bringing in the parts through the harbour or airport, and when they are going out to countries in the region," states Gunnarsson. "Our system is very efficient, but we are always looking for ways to improve." 

Trust in MAN: LTS Group takes delivery of 70 trucks

Leading transportation service provider, Lee Ting San Group of Companies (LTS Group), has expanded its fleet by seventy MAN TGS 19.360, 4x2 prime movers intended for long-haul transport.



The hand-over of the trucks is just one of two milestones for the company in a move to ensure better and reliable service to clients. The bright yellow MAN TGS trucks that were delivered early this year and handed over in an official celebration on 9th January will make up one third of the logistic specialist's existing fleet of prime movers. Together with the intake of the trucks the company also celebrated the opening of their new logistics hub and warehouse. Boasting some 8 000 square feet of office space, the premises offer

warehousing and the ability to control the fleet via telematics system housed in the new Headquarters.

Based in Prai, the company has a haulage hub and distribution centers located in various locations across Malaysia including Pulau Pinang, Prai, Port Klang, KLIA and Bukit Kayu Hitam and commands a fleet of close to 1 000 vehicles that support its nationwide and cross-border transportation services. The Group services blue chip clients such as DHL, Schlumberger, Dell and KLM, and



has a distribution network that extends all across Malaysia as well as to Singapore and Thailand.

TGS for LTS

According to Lee Kah Chye, CEO of LTS Group, the TGS strikes the perfect balance between performance, payload and decent fuel consumption, to help the company achieve lower total cost of ownership. This is especially important in light of the present economic situation and the rising cost of doing business. In addition, MAN trucks are comfortable



and easy to drive and this will benefit our long-haul drivers he said during the ceremony.

The 4x2 tractor which weighs around 360 kg less than a standard prime mover offers considerable advantage when it comes to payload while being extremely lightweight. It can travel along asphalt

roads or unsurfaced gravel tracks and its high-torque Common Rail engine provide the necessary dynamics with low fuel consumption.

The twelve-speed MAN TipMatic® semi-automatic gearbox of the vehicle takes the pressure off the driver as it can be operated effortlessly, either fully



automatically or manually using a touch-action lever on the steering wheel. With the single sleeper cab in the MAN TGS, the driver can also enjoy a high level of comfort, a generous amount of space and a clear view, with a full standing height.

Lee added that having MAN's service center located close by at Prai is another advantage, as this makes it easier to schedule upcoming maintenance and response times are swift. This enables the company to maximize the lifespans of the trucks and get them back on the road as soon as possible.

Hartmut Mueller, Managing Director of MAN Truck and Bus (M) Sdn Bhd said "A key objective of MAN is to supply fuel-efficient trucks that significantly lower total cost of ownership and it is encouraging to know that the LTS

Group has found the MAN TGS more than capable of meeting its stringent requirement in this area."

Innovations to lead

LTS Group of companies is known for being an early adopter of state-of-the-art technology. The recent push is part of a massive transformation drive in their operations, brand and management. Lee acknowledged that this transformation did not happen overnight, but had already started in the late 90s. "The 9th of January 2016 marks the achievement of two significant milestones in Lee Ting San Group's history. First, we are officially launching the opening of our new headquarters in Juru Auto City. It is built with an investment of RM8 million and covering a land area of 10 acre" Lee said in his speech.

The landmark building will serve as LTS Group of Companies' corporate headquarters to support the company's growing business. Not only being a new building to be proud of, but the inside is the real centerpiece of the operation. This is where an operations team monitors LCD panels that provide real-time information about the truck routing. Internally, the GPS tracking control room is what LTS Group calls the brain of their operations.

Although still a privately owned company, it is the company's leadership that decided to invest in high-value assets and adopting the latest technologies to cope with increased demands of global trade. This transformation has enabled them to grow from a small transport agency transporting the daily supplies & foods, into a regional haulage and distribution powerhouse transporting high-value goods and high-tech electronics products. Lee is proud to proclaim that "LTS Group is said to be on par with multinational corporations thanks to our commitment towards constant improvement and technological innovation."

Collaboration to compete

In the long term, LTS Group believes that the collaboration with MAN will give them a major competitive advantage in the market. Through this partnership, the company is also strengthening its continuing efforts to invest in Malaysia's future in logistics, especially with the advent of the "One Belt One Road" initiative. As a regional logistics player, they see "One Belt One Road" as an important source of future growth





for ASEAN countries and excellent opportunities for logistics players. In addition, MAN trucks are comfortable and easy to drive, which will benefit drivers to get jobs done.

Also present was Encik Mohd Azharuddin Bin Mat Sah, CEO of Land Public Transport Commission, who praised the efforts of LTS. He said "Safety is our primary concern and we aim to engage with the industry to push this agenda." In his view, it is crucial to work with leading companies that can influence others to step up their efforts in terms of safety. According to Lee, the bright yellow colour, chosen by his father when he founded the company, in itself is a safety feature as the vehicles are visible from far thanks to it. An in-house safety committee overlooks the activities of the operation and trains drivers on safety. In Lee's view, drivers must be trained for several reasons. One is the fact that drivers are customer facing and therefore they "Not only take care of the load, but also of the customer". Furthermore, the drivers have long since become operators. "The term is "to operate", not drive anymore. Back in the old days,

you needed to drive a lorry, but today you really do much more, the person is now an operator of a complex machine".

LTS Logistics Sdn Bhd was recently awarded "The Best Freight Operator (KA)" in the SPAD Land Public Transport Symposium 2015. Lee would like to thank SPAD for the honor and pledges to continue bringing meaningful improvements to the industry and to work hard at keeping Malaysia at the forefront of logistics in ASEAN and beyond. **F**



Linfox buys new trucks to support gas giant



It might be the model client for Australian logistics service provider Linfox as Linde not only shares the same first letter in the company name, but also the mantra on safety on the road without compromise.

Although held under an overcast sky with looming rain, the moods were sunny on the 15th of December when Linfox (Malaysia) took delivery of their new trucks. Three truck makers were present to hand over their vehicles which were integrated into the local fleet of this global company.

Witnesses to the event were several members of Linde's staff who had a keen interest in seeing these gleaming new vehicles which heralded the arrival of a new era for the company.

Linfox - An Icon

Linfox is Australia's largest privately owned logistics company that is rapidly expanding throughout Asia and New Zealand. Today, there are more than 23,000 people in 10 countries working across five industry sectors: Fast Moving Consumer Goods (FMCG), Retail, Resources & Industrial, Australian Linehaul and Government & Defence.

Linfox is owned by an iconic Australian family however more than two-thirds of their growing team is based in Asia. The company works with the world's largest natural resources company, the world's two largest consumer goods companies and one of the world's largest retailers.

In an exclusive interview with Saj Iqbal, Country Manager, Malaysia, we learn more about the company and their motivation to add new trucks to their fleet. According to him, the addition of the trucks is in line with the business being a 3-PL provider



offering transportation and warehousing with a focus on in-land transportation. "We are a multi-national company and when we partner with our clients we want to invest in our own infrastructure" he said, "Malaysia was the first country the company expanded into after Australia and New Zealand."

"With presence in eight countries in Asia, the largest labour force is in Asia, and the transport network is growing fast in Asia. Linfox invest heavily in bespoke fleet tailored to their client's needs through out Asia. This is supported by a local fleet team working in parallel with global manufacturers and local Linfox operations. True collaboration."

"The question is: how to add value to customers?" Saj explains. "One could work with subcontractors, but that would not fully allow Linfox to offer customized solutions as they do for customers like Linde. Developing a joint fleet solution for the client is a winning solution."

When walking into the Linfox office, many people wear safety vests and posters remind everyone of steps to be taken in order to ensure safety and wellbeing of everyone. The notion of "Safety" is one of the cornerstones of the operation and is being taken extremely serious. Another way of looking at this is to label it under "Integrity" as the company will not work outside legal limits. Overloading is not only frowned upon, but completely out of the question, so is working longer than legally allowed. Linfox will reject jobs that would result in the company violating any of law, rule or regulation.

Sitting in his office, Saj can see directly into the control room, monitoring all the trucks on the road. Using a fleet management system, he can control safety precautions such as areas allowed for breaks, resting times, working hours and other measurables crucial to Linfox.

Linde - A Gas Giant

The Linde Group is a world leading supplier of industrial, process and speciality gases and is one of the most profitable engineering companies. Linde products and services can be found in nearly every industry, in more than 100 countries. A success story that began with the separation of air. Here is what Ashley Mills, Managing Director, Linde Malaysia Sdn. Bhd. had to say about the investment made into safer transportation of the products labelled with their name:

"Linde has invested in new vehicles to ensure that we continue to operate our business responsibly and sustainably. There are three important elements we believe are necessary:

Firstly to constantly strive to improve safety. Truck design continues to evolve and given the challenging conditions our drivers face on the roads every day, we wanted them to have more comfortable cabs, better vision including improved mirrors, access to in cab technology including reversing and in-cab cameras and on board computers and stronger vehicles in the event of a collision. I believe that this investment will help to keep our



drivers, other road users, and our customers safer. I have personally travelled with our drivers in their deliveries and have seen firsthand how difficult their jobs can be with more and more vehicles on the road each year.

Secondly we wanted to improve our customer experience and that means reliable vehicles. Put simply, I need them on the road and not constantly under maintenance. Our "commitment to promise" to our customers means our vehicles cannot be breaking down on en route to our customers premises. This is true for all customers but especially important for our fast growing healthcare business where it may be a matter of life or death for patients.





Finally improving our efficiency. Rising costs of operations mean we are constantly looking for competitive advantages whether it is in fuel efficiency or total cost of ownership. These vehicles will consume less fuel per km travelled, thus reducing emissions and this is better both for business and the environment.

Linde will continue to upgrade its fleet as part of this program and I look forward to seeing more new vehicles on the road in 2016.”

The Chosen Ones

Linfox has a dedicated, self governing fleet department. With the large number of trucks owned, Linfox has buying power advantages and a replacement plan to maximise fleet efficiencies and reduce running costs. The company has always

purchased vehicles that were and are state-of-the-art when it comes to safety features eg, trucks have to have ABS and other safety features not found in the more value for money brands.

Another criterion for Linfox is the service network offered by the truck OEMs along with the requirement that the assets need to run efficiently, the company has a list of preferred suppliers. In Asia, the availability of local trucks is becoming more popular as safety features have improved considerably and running costs remain competitive.

With the new fleet at Linde, Linfox will have an increased capacity with reduced trucks on the road. With the new trucks, the environment will be taxed less as there will be fewer trips with less emissions per kilometre, whilst still offering delivery flexibilities.

HYVA - Lifting the brands

For this new fleet of Linde-Branded truck Hyva Malaysia SdnBhd recently supplied 26 units of Dhollandia column lifts, specifically for the handling and transportation of gas cylinders.

Hyva Malaysia Sdn Bhd which is the Malaysian subsidiary of the multinational Hyva Group of companies, has had a presence in Malaysia since 1991 and has been providing quality handling products for the transportation industry ever since.

Dhollandia, which is headquartered in Belgium is the leading manufacturer of hydraulic tail lifts in the world, having been around since 1968. The company has a production capacity in excess of 35,000 units per year and sold more than 550,000 units since 1968.



Hyva Malaysia has been the sole distributor of the Dhollandia tail lifts in Malaysia since 2005. This dynamic partnership has proven to be very successful due to the provision of reliable and quality driven products as well as a keen insight towards local transporter requirements developed over the years. The products are also backed up by a speedy and efficient after sales network.

The column lifts were custom designed for Linfox operations at Linde for the handling of gas cylinders with the following in mind:

- safe and reliable, robust yet lightweight in design
- flexible and client- oriented
- superior finish
- quality low maintenance components
- economic
- safe environment focus

For Linfox the Dhollandia column lifts were used as they offer maximum all-round efficiency. These are specifically designed for the Linde / Linfox applications with the added feature of a single piece aluminium platform. Dhollandia is able to offer a wide choice of column lifts specific to individual requirements. These platforms also boast a number of safety features, in line with Linfox's and Linde's approach to zero incidents.

Firama - Putting it Together

Seremban based body builder Firama built the rigid bodies for Linfox. These bodies are special because they offer quick and safe loading/unloading of the gas pallets. The rear lift handles the arduous task of moving individual cylinders from floor to truck and vice-versa.

Commenting on the project, CC Yap of Firama said "Working with a reputable company like Hyva (M) Sdn. Bhd. is great because we can engineer most of the structures before the lifts arrive. We are able to avoid pitfalls and plan the best and most efficient method of mounting. We proposed the alternative method of welding the lifts to our end columns and this was accepted by Dhollandia, Mr. Pol Derie. Our contention was that welding is a simpler and more positive attachment and will avoid future maintenance issues."

"We are grateful to HYVA for their quick action in supplying the lifts early and our technical staff for their intensive efforts" added Yap.

To comply with the stringent safety requirements for the trucks, the first component of choice are Dhollandia lifts. An additional control is installed close to the lift so that it is only a "one man operation" all the time. The lift comes with a hydraulic dampener which smoothens the unfolding of the platform in a "stepless" manner. Again, the operator can operate close to the platform in a comfortable way. Locks are also designed to lock the pallets when in transit. Wheel chocks are provided in a stowage box near the rear wheel which is a standard operating requirement. These chocks are chained to its stowage.

In closing Mr. Yap said, "We are pleased that Linfox was agreeable to our proposed specifications and I compliment both Linfox and Linde working in partnership on this project" he concluded. **F**





PKT Logistics Smart Trucker Program addresses driver shortage

Sometimes you have to take matters in your own hands, as did Dato' Michael Tio when he created the Smart Trucker Program for his transportation business in order to address the need of truck drivers in the county.

Globally, not only in Malaysia, there is a shortage of drivers for commercial vehicles. Dato' Michael Tio, Group Chief Executive and MD for PKT Group, has created the Smart Trucker Program to address the issue and to upgrade the trucking industry in Malaysia. After visiting their office, this innovative approach is not a surprise to us as PKT is forward thinking in many ways. Two gyms are accessible to all employees. The employees go home when the work is done and not when the clock strikes 5:00pm. Each floor of the Lighthouse office building is built with a different theme and design.

"We want to create a fun working environment, whereby we create happiness, ensuring the employee is healthy, and that we are honest with each other in whatever we do," says Dato' Tio. The company operates a college in the office building that offers a two year programme in Logistics Management, Accounting and Business studies. According to him, "If doctors can be taught in a hospital environment, why not a future logisticians in a logistics center? PKT is a 'Facebook Compulsory' company, through this interface, they do their hiring and with this approach, the company has a list of over 10,000 people waiting to work for them.

The Smart Trucker Program aims at adding resources to the business. Instead of hiring drivers and training them, PKT engages with local universities and polytechnics in order to

attract fresh graduate degree holders. A negative perception of truck drivers means that fresh graduates don't even think of being a trucker. They want to change the negative perception and at the same time upgrade the standards of truckers in Malaysia. Firstly, the fresh graduates get paid during the six-month training period. When they obtain their driving licenses, they will be 'graduated' as a Smart Trucker. The Smart Truckers are expected to drive for four years before they can opt for a



ASIAN TRUCKER



SUBSCRIPTION FORM

Personal/Company details

Mr/Mrs/Mdm/Ms :

New I/C No :

Company :

Address :

Tel no (O):..... (HP:.....

Email :

I hereby enclose RM Cheque.....

being made payable to Asian Trucker Media Sdn Bhd

4 issues RM40

6 issues RM60

Mail/fax this form to:

Asian Trucker Media Sdn Bhd (902834-K)

Empire Tower,

A-5-9, SS16/1, Subang Jaya,

47500 Selangor

Fax no: 03 5021 8594



more stable executive job. This promises them a clearer career path where they won't be stuck as a trucker for their entire working lives. This programme ensures that the employee understands the dynamics of the business as they will face the customers on a daily basis. As a graduate, they will learn how to plan with better time management. "As a truck driver they actually earn more than twice an executive level income. They have the extra income for savings and by the time they move from being a trucker to working in the warehouse, they will have a handsome savings account for them to get married, settle down and have a family," DatoTio explains.

During the six month training period the students learn on how to drive a truck and go for their truck driver's licenses once they are ready. After four years, they can opt for an executive level job in the warehouse. Having worked as drivers will help them as they now understand better how route planning is done, managing schedules and how to deal with paperwork. Dato' Tio points out a few more interesting aspects of the programme. For example, with the AEC (ASEAN Economic Community) now in full swing, drivers will actually get to see more countries as they travel during work. They will learn what is needed in order to do clearance for crossing borders with trucks and they get familiar with the entire terminology of the trucking and logistics business. By the time they work in the warehouse, other drivers won't be able to spin them with stories as they have been there themselves and know the reality. The training is structured in a way that takes the graduate through a month of training in the operations office before they move to train in the workshop the following month. From the third month onwards they will get a feel of driving a truck by following senior drivers on their trips and they will also be trained in the yard for parking and reversing.

A graduate of the very first intake into the program, 24-year-old Muhamad Hariz Bin Mohd Borkhan speaks highly of the programme. "I like this programme as it is the start to a lifelong career. I can earn a lot in my early years while others may not make as much as a degree graduate," he said. Having trained on a Scania 380, he is now driving a haulage prime mover. He echoes the sentiment of many in the industry who think the profession is perceived as a low grade job, but on actual facts it is in high demand. He said, "It is very exciting to be driving such a 'monster' like the trucks we have." Having support from his parents makes it easier. His mother is a lecturer in a polytechnic and actually encouraged him to enroll in the programme. So far, the highlight in his early career days has been the full day of safety driving training in Sendayan. "It was tough in getting used to driving a truck," he said.

Talking about the future plans for the programme, Dato' Tio hopes that more companies will introduce such initiatives. "I would be happy if others were to follow and implement this programme. After all, this is good for our nation and we need to strengthen our own people in order to stay competitive in the ASEAN region."

As a start, there are four graduates who have joined the programme as the first batch intake and who have 'graduated' as a Smart Trucker. For the next intake, PKT hopes that the reputation of Smart Trucker will entice more students to take up this opportunity. We can expect the Smart Trucker Program to be presented to all Universities and Polytechnics around the country to move forward towards the critical mass for change in the trucking industry. **F**



Fifth Wheel Coupler



King Pin



Landing Gear

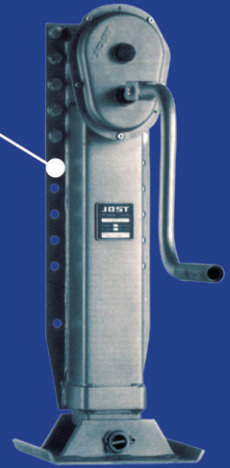

ALL KIND OF WINDSCREEN FOR TRUCKS & CARS



Hydraulic Tipping Hoists

Edbro

Leading the market with product developments ever since 1916

Member of **JOST**-World



HYDRAULIC PUMP

Bend-Axis Pump

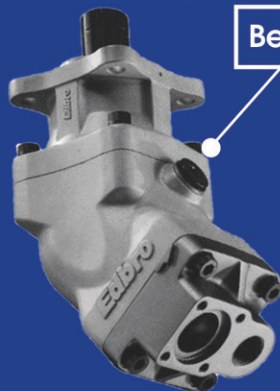

Iso Gear Pump

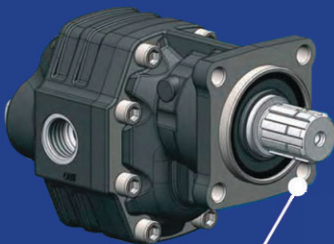

Buffulo Mobile Batching Plant Uses JOST Landing Gear & TKK Trailer Component



U-LI AUTO PARTS & SERVICE SDN.BHD

(350857-M)

NO. 54, JALAN BESI, BATU 3 1/2, OFF JALAN SUNGAI BESI, 57100 KUALA LUMPUR. W. MALAYSIA.

TEL: 603-7980 8429 / 7980 8430 / 7980 8431 / 7984 3428 / 7983 8428 FAX: 603-7980 8433 E-MAIL: uliauto@gmail.com



Continental talks about Trailer Tyres

Specifically designed for the use on trailers, these pneus carry the load.

As with the steer and drive axles, there are tyres that are specifically designed to be used on trailer axles. Continental sheds some light as to how to take care of them and how to get the most out of each tyre.

1) Why do we need tyres specially for trailers?

Every axle on a truck has different requirements. While steer tyres perform best in handling and changing the course of a heavy duty truck, drive tyres take up the utmost traction from various surfaces. The ribbed pattern on trailer tyres are designed to perform best on the trailer axle position, where they withstand strong lateral and braking forces with varying loads.

The slightly shallower tread depth in the trailer tyres as compared to the steer tyres reduces the swaying effect and rides cooler (less amount of rubber) which eventually leads to great tyre longevity.

2) What does the development process involve? How do you create new trailer tyre types?

A lot of the development process revolves around research and how the products are fairing in the market. Continental takes a lot of time to listen to the feedback from drivers, fleet managers and distributors whose personal accounts with the tyres provide the best insight on how to continuously improve.

Through the excellent performing HTR, CHT3 was developed by enhancing the key features to further be the benchmark in the market place.

Based on the ever growing demand of load conditions, CHT3 has the enhanced cord strength and a new compound in belt layers, which results in the improved casing durability and endurance.

CHT3 has stiffer and more robust sidewalls which enables the tyres to withstand the high load of trailers and lessen the risk of any premature failures,

As an example, CHT3 was also developed to better suit Asian road conditions. It features improved groove geometry for better stone ejection, hence enhanced pattern robustness, and optimum wear rate.

3) How to manage / maintain trailer tyres

It is absolutely essential for stability and safety that all tyres are correctly inflated according to the applied loading condition, and kept in the best condition at all times.

Overloading is a serious safety hazard and should be avoided at all costs. Overloading also causes uneven wear and reduces the longevity of the tyres.

4) Should there be different tyre-configurations for trailers with 1, 2 or 3 axles?

Yes, but this is a very meticulous topic which would weigh in many factors, some of which include the pay load and vehicle weight.

5) Are they (Trailer tyres) retreadable?

Yes, most definitely. Especially with the new CHT3, the tyre construction has been enhanced with features that enables the end user to optimize the tyre life, not only benefiting from the high mileage in the first life, but also in the lives thereafter.

Further retread information is available on the sidewall of the tyre for the retreading process.

CHT3 should be retreaded with Continental retread products to achieve the optimum tyre life.

6) What are the products Continental is planning to launch in the near future in Malaysia?

Continental is looking to launch the CHD3 in late 2016 and the ContiCrossTrac in 2017 after having just launched the CHS3 and CHT3 this past 2015. 



JOSAM Sweden

**With more than 40 years experience,
we offer Unrivalled Expertise in**

Truck Frame & Cabin Repair



All Wheels Alignment for Trucks, Buses, Trailers, Cranes ...



Induction Heating



Manbeni Machine Tools (M) Sdn Bhd (268550H)
No. 21, Jalan 5/118C, Desa Tun Razak, 56000 Kuala Lumpur, Malaysia
Tel : 603 - 9171 6323 Email : admin@manbeni.net
Fax : 603 - 9173 9323 Website : www.manbeni.net



Introducing APPs into logistics



As an innovative service, this online application harnesses the power of the internet and the idea that there can always be a better way of managing resources in logistics.

One definition of business by company owners would be: it is the process of problem solving. A business' purpose is not only to make money but also to figure out how to lessen the burden of others by offering a solution to problems. This is where creative thinking takes place, eventually improving our industry. We met two young men that managed to develop a fast growing business (now) from an idea that they had during a conversation during their lunch break.

Mr. Nadhir, and Mr. Goh, both 27 years old, are the founders of The Lorry Online Sdn Bhd (www.thelorry.com). Many of us are familiar with Uber. It is an application that operates as a medium to connect private vehicles to work as a public transport. The underlying principle of The Lorry.com is the same concept as Uber, but they connect owners of light duty trucks with people having a need to transport goods.

“We were both working in the logistics industry. One day we had a conversation over lunch about what seems to be the problem in the logistics industry, still. We came across one problem which was that it is still a difficulty for people to find a lorry to move things from one destination to another, especially if it is a short distance. For truck operators, one difficulty is to extend their services in certain areas” said Nadhir.

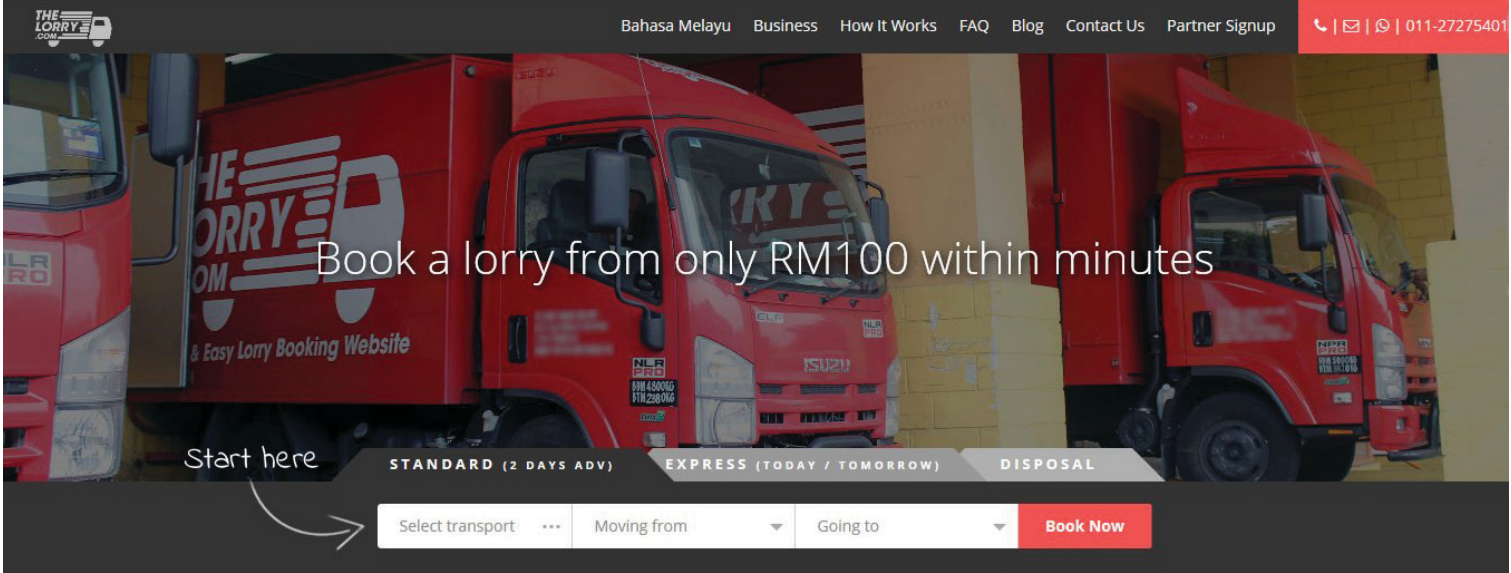

Book a lorry from only RM100 within minutes

Start here

STANDARD (2 DAYS ADV)

EXPRESS (TODAY / TOMORROW)

DISPOSAL

Select transport ...

Moving from

Going to

Book Now

“Our first step for the business was to set up a website and then collaborate with truck operators to build up a pool of vehicles available for bookings. It took us about five months preparation before we launched the website “TheLorry.com”. We now provide a service that connects trucks from one to five tonnes, with the lowest booking fee starting at RM100 for 10km,” he added.

The term “Logistics” obviously covers few areas such as air freight, sea freight etc. The founders of TheLorry.com decided to choose the business in road freight because there are less terms and regulations to start the business to adhere to. The business is more focused on individual customers and requires a lesser amount of investment. The beauty of the business is everything can be done online nowadays.

As a customer, you just need to fill in the end-points of the delivery (from where to where), and type of transport (a van or lorry). Within a few seconds you will receive a quotation of the price to match your need. You may then choose add-ons if you need manpower, boxes etc. If you only need to move goods once in a while, this is obviously making moving a hassle free and very efficient process.

“Our first booking was on the following day after we launched the website. Since then the business started to grow and we now receive bookings almost every day. Our vendors are mostly independent; they are owners of the lorry and typically also the driver” said Goh. After six months they got themselves a small office and eventually moved to a warehouse office.

How does TheLorry.com control the quality and safety?

When a business in our industry grows rapidly, quality and safety will be the main concern because you don’t want to lose customers’ trust. According to the two, they have created a system of stars merit and it is included in the application for customers to rate the services received. For example, if you, as the lorry operator keep receiving only one star, you will get notification of the job later than others who have received more stars. Those with more stars will be notified as fast as possible.

Currently, the platform has 250 contractors with over 1 000 trucks all over Malaysia. The portal is managed by 19 people in TheLorry.com team.

Feedback from the fleet

Sabri Salleh, 45, owner of three light duty trucks, is very happy with this innovative idea. “Before I joined TheLorry.com, I was

handling the offline marketing myself, and the business was still slow. I got to know about TheLorry.com in Kosmo newspaper and then I registered with zero fee. My business increased almost 60 percent and I have customers that need my lorry everyday. This kind of application is a good platform for the truck operators and it is also convenient for the customers. As there is a rating system, it gives more confidence for customers to use our service.”

Echoing this, Ahmad, 42, an owner and a driver of two light duty trucks said “I joined TheLorry.com in May 2015. This platform helped us a lot in developing our business and ourself. We no longer need to look for customers, customers find us. The 10 percent commission given to TheLorry.com is totally reasonable for us.”



JA Security and Innovations gives shippers peace of mind

New in the market, offering automated technology systems for remote GPS tracking, monitoring and management in Asia, this company may just offer what you need to further secure your goods in transit.

JA Security and Innovations Pte. Ltd. was spun off from JA International Group of Companies in 2013. Parent company JA International has been operating for over eight years, traditionally as a business consultancy in Singapore and the neighbouring countries.

JA Security and Innovations' solutions leverage on technology developments in ICT, Internet of Things and Big Data. The company offers products and services ranging from GPS tracking devices for vehicles, shipping containers and portable tracking devices to anti-counterfeit solutions for brand protection. With these solutions, the company offers live online tracking and its IOS and Android Apps are localized in 35 languages.

"Being in the security industry, I do realize that there are certain needs for security products, especially in the logistics industry. Our product is not a standard tracking product. It is unique and reduces hassle as it is a wireless product," said Mr Sanjay, Country Manager.

Introducing FreightCheck

Termed "FreightCheck", it is a secure monitoring solution for ensuring safe delivery of containers from origin to destination. It detects in real-time the container's GPS position, door open/close, break-in and impact. The installation takes 30seconds only. This container tracking solution, whilst patent pending, has been tested and approved by Lloyd's as satisfying a key policy condition of its high value cargo insurance.

"A Type Approval from Lloyd's Register demonstrates that your product conforms to recognized industry quality standards, international conventions and/or the LR Rules," he explains.



"I believe if a company is carrying high value goods, they would definitely prioritise on the security of the goods. The FreightCheck container tracking system serves and provides real time data to all parties interested in the delivery of the shipment. It allows all those involved to coordinate their efforts to ensure their shipment obligations are being met or in times of need, to take action immediately and in an orderly manner," said Mr. Sanjay. **F**

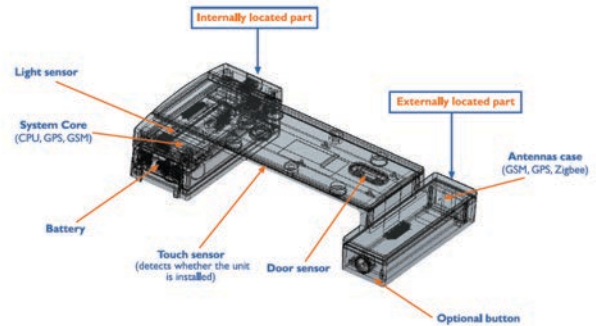
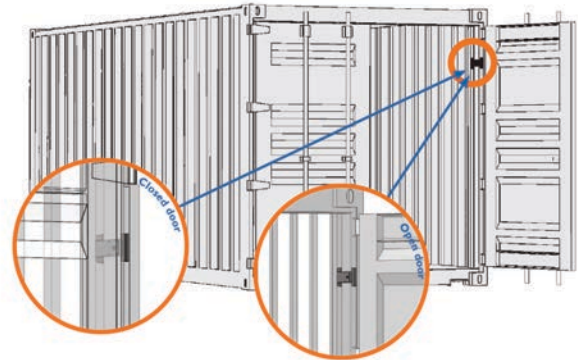

FreightCheck R for reefer containers offers the same function, but has a few additional features:

- Built-in temperature and humidity sensors
- Connection via RF to external temperature to humidity sensors
- Built in Light sensors: 360 degree
- USB connector: for initial setup and to collect data which have been logged
- Long battery life: over 3 months
- Installation and activation within 60 seconds



MAXIMISING TYRE PERFORMANCE



Cause and Effect Factors Affecting Tyre Life

Actively tracking



Since their debut in May 2015, Active Telematics has been true to its name and being busy in the background with the creation of new products and building a solid customer base.

activetelematics
www.activetelematics.com

While everyone agrees that the year 2015 has been slow and challenging for many, Hardev Singh, Sales Manager of Active Telematics, has a very positive outlook for this new year. According to him, the industry is actually booming. Certain sectors, like Oil and Gas, may be in decline, however, he states that this means that other industries will be on the up. "We see a lot of movement on the roads, people are interested in how to improve their business," he says during our exclusive interview.

The internet is also becoming a major tool in the transportation industry. Already known as IoT, or "Internet of Things", many aspects of this sector depend on, and are growing with, the internet. "While Active Telematics does not get involved in the

back- or front end of this, we can see a lot of benefits here. Once the installation of the devices is done, everything is done over the air," he explains. This means that the settings, controls and monitoring can be done from anywhere and by anyone with access. One key aspect of the use of the Internet is the fact that the data will be protected as IoT makes things tamper proof. Active Telematics sees a lot of potential in Malaysia as the users here currently don't use the full spectrum of functions available to them when installing a tracking device. For example many are still happy with accuracy of 5 meters whereby the latest technology can be as accurate as 2.5 meters with up to 10 second reporting intervals. Changing mindsets has been a challenge for the young company, which debuted at the 2015 instalment of our expo.

As a newcomer, Active Telematics is happy with their achievements for 2015. It has been a year of base-building and securing the first customers. Currently, some 500 units are installed and the company has ticked off their first milestones set. Asked about their strategy, Hardev explains that "This year was crucial for us as we needed to understand the needs of our

Mobility In Control

...by adopting KL Sigma Formula



target market. There are many out there that can give you GPS tracking. However, we work in a different way. We give our clients a customised solution, according to the specific requirements of each company". Therefore, the company aims at reducing costs, increasing productivity and to eliminate redundancies. Offerings from Active Telematics are to improve the service experience of customer's customers. "We can be proud of ourselves as we haven't had any major glitches in terms of service delivery," he beams. This is particularly interesting in view of the fact that they also offer cross border coverage.

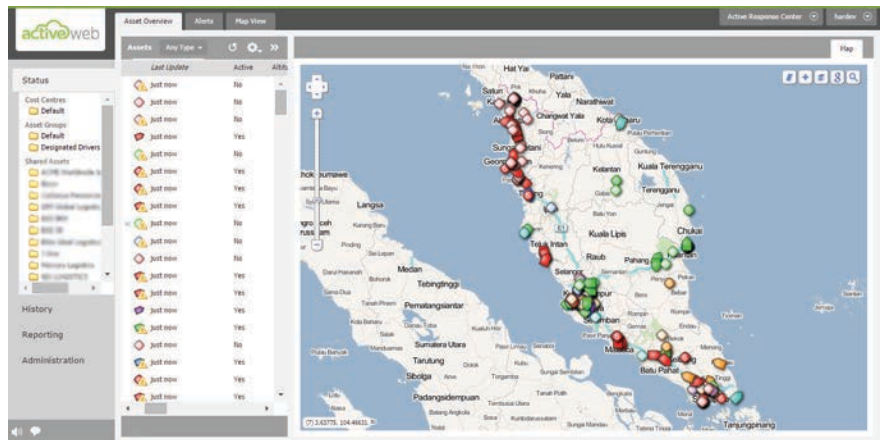

ActiveWeb

Starting the new year with the launch of a number of products, customers can look forward to seeing solutions that will exceed the mere provision of a location on a screen:

Active Tank

Although not a solution for trucks, this shows the versatility of what the platforms offered can do. Suitable for applications in tank farming, this module tracks the capacities of liquid bulk materials, such as Crude Palm Oil in fixed tanks in real time. This will give operators the edge as consolidation doesn't take hours as factories are able to measure their stock at any given time without manual measurements.

Active Trailer

Most systems are installed in the prime mover and allow for a number of functions related to the truck. However, in case of theft, typically, the trailer is decoupled and taken away while the prime mover is left behind. This system is independent, not using the power source of the truck, but its own and can stay active for up to 365 days. When stationary, the system provides a health report and when on the move relevant data will be transmitted. In case of separation of the trailer from the truck, the trailer can be tracked separately. Not only would this be suitable to track stolen trailers but also to manage inventories in companies renting out their trailers.

Active Container

This lock for containers is designed to mechanically lock the doors of a container and at the same time monitor the openings

/ closings of them. A tracker inside the lock captures the times when the doors were open, thus giving operators the possibility to counter theft. This gives an advantage over the commonly used seals as these can be tampered with. The system also works across borders.

Active Eye

Two cameras mounted in the cabin monitor the driver and the road ahead of the vehicle. These cameras record non-stop, sending the stream into a cloud. In case of strong G-Force alteration, a 14 second video will be send to the operator. The video will capture seven seconds before and seven after the incident to allow for an assessment. The exact location of the incident will also be recorded and shown on a map. As the system is using a cloud, no more SD cards are needed, which could get damaged. Also, the reporting is instantaneously and eliminates waiting for the vehicle to come back to the yard. Apparently, this system is already being used by all Black Cabs in London.

When asked about the year ahead, Hardev is very positive. Having achieved their first milestones and several key customers now with them, the company is looking at setting up local offices across Malaysia and eventually overseas, too. Given that all products are SIRIM approved, he sees no reason why the market wouldn't accept their solutions. "We see technology as a platform. There is a lot we can do for the industry in order to improve their businesses," he concludes. **T**





Q-TWO (M) SDN BHD



Trucking - Warehousing - Outsourcing

No. 110 & 112, Jalan Selat Selatan, Taman Perindustrian Pandamaran, 42000 Port Klang

Depot : Lot 15168 & 15169, Jalan Tengah Off Jalan Telok Gong, 42000 Port Klang

Ipoh Depot : Lot 301762 (Plot S227 Ipoh Country Park) Batu 3½, Jalan Kota Bharu, 31600 Gopeng

Enquiries : Tel 03-3168 1181 Fax 03-3168 1989

E-mail : biznes@q-two.com.my

Associated Companies

PERMAI DAMAI (M) SDN BHD

PHANG ENTERPRISE SDN BHD

GEMBALA MUTIARA SDN BHD



The way to make our roads safer is to change people's behaviour

What price for a life?

Malaysia has one of the highest rates of road accidents among the countries in the world.

From police statistics, 65 per cent of accident cases were caused by human factor. Accidents kill, maim, seriously injure and that is just the human cost. And then there is the cost of vehicles being destroyed, damaged or off the road.

It is claimed that 90% of all incidents and collisions are caused by driver actions. This is generally not a driver's actual ability to drive, but the result of their behaviour, attitude and personal choices.

It is all too easy to be lulled into a false sense of security in the relative comfort of the cab of a vehicle. Accidents happen to other people. But then that sense of security is shattered by a momentary lapse of judgement. You only have to take a look on the internet to see on YouTube horrific footage of road accidents and how it only takes a split second between leading a normal life and the prospect of death.

It is all too easy to blame others and maybe sometimes others are at fault. However looking after yourself and other participants on the road has to be your number one priority. Road safety is everyone's responsibility.

The only way to make our roads safer is to change people's behaviour, to focus on the defensive qualities of awareness, anticipation and alertness.

The challenge we face is not the acceptance of how important driver safety is. Most people agree that it is a major danger and problem. The real challenge is actually doing something about it. It is only when you face the prospect of losing something that you realise how valuable it is! You only get one life, so it would be a waste to lose it needlessly! To repeat, road safety is everyone's responsibility and the way to make our roads safer is to change people's behaviour.

If you put this in the context of work, driving a vehicle can be one of the most dangerous activities an employee will undertake in the workplace. In many countries, protecting employees on the road is a challenge. People who drive for business are up to 50% more likely to be killed on the job than construction or agriculture workers.

When you look at the global market trends, many companies and vehicle fleets are now moving towards web-based training to compliment traditional behind the wheel training. Companies are beginning to centralise training programmes instead of allowing individual countries or regions to conduct their own programmes, plus they are looking to leverage mobile devices to deliver training which is easily accessible for employees.

In partnership with driver safety solution provider FleetSafe Asia, Asian Trucker Drivers Club is offering an online e-learning driver safety training programme which is the most advanced system of its kind in the world.

The online programme, developed by AlertDriving, is used globally in over 70 countries in 108 different languages. It is not about trying to teach anyone to drive. Instead, the focus is on reinforcing the need to drive safely and to increase awareness and the programme has routinely seen a 30% reduction in collisions, coupled with a reduction in the severity of their collisions.

The programme identifies a driver's hazard perception profile based on their ability to identify dangerous situations that happen every day on the road. This includes real life traffic scenarios and multiple-choice questions regarding the safe operation of a motor vehicle. Based on this evaluation the system determines which training modules each driver will need to complete.

The training modules use real life video footage, which leads to better retention rates by drivers and they are individually

customised with local country footage and languages. The modules are designed to only take 15-20 minutes to complete, saving time and keeping employees productive with their daily activities. Modules can be undertaken on mobile phones or tablets and are spread over a period of time, not all at once and the system automatically corresponds via email with drivers that have overdue lessons and this subtle reminder significantly improves compliance.

The programme is used by many of the world's leading companies and specifically in the Asia Pacific region, one of FleetSafe's major clients is the multi-national dairy company Fonterra, who in Asia and the Middle East, have over 470 drivers participating in the programme across nine countries in six languages.

In Malaysia alone there are a total of 280 drivers in the language variations of Malay, English and Chinese. This is part of Fonterra's continued safety awareness programme to help its people reduce the risks of being involved in an accident whilst driving on the road and the programme fits their criteria to increase drivers driving safety awareness and to ensure that they go home safe every day.

FleetSafe Asia CEO Peter Burns commented: "We receive lots of positive feedback about how easy the programme is to use, how it gives a refresher driving course, making people aware of potential hazards that may be a threat in real life traffic, through providing situations for the drivers to experience and practice. The most important thing is that participants actually enjoy the experience, proving that learning can be fun, plus it could save your life!" 

AlertDriving is a Toronto-based software company specialising in driver risk management. Established in 1998, AlertDriving works with multinationals corporations as diverse and far ranging as Coca-Cola Hellenic, Philip Morris International, Novartis, W.R Grace, and more.

FleetSafe is a fleet vehicle solution provider, offering driver and fleet risk evaluation, education and road safety programmes. Pioneered in New Zealand, now with international regional expansion in Australia and Asia, working with companies who operate both light and heavy vehicle fleets, to improve driver safety, reduce costs, increase fuel efficiency and improve health and safety compliance.

Asian Trucker Drivers Club is a partner of AlertDriving and FleetSafe. Interested parties may request presentation meetings for the online training system by writing to info@asiatruckerclub.com.my

Malaysia Special Offer:

To start making the year 2016 a safer one for everybody on the roads, we are offering the following modules as introduction specials:

Hazard Perception Evaluation with prescribed Defensive Driver Training Modules = S\$ 190 per person

6 Targeted Defensive Driver Training Modules (2 & 4 wheel powered vehicles) = S\$ 120 per person

Malaysia Special 3 Targeted Defensive Driver Training Modules = S\$ 75 per person



[Halaman Utama Aktiviti Saya](#) | [Tetapan Bahasa](#) | [Meja Bantuan](#)

GANGGUAN TUMPUAN BERBAHAYA

Sila semak bahan yang ditemui dalam Langkah 1, 2 dan 3. Apabila sedia, teruskan dengan mengambil kuiz dalam Langkah 4.

LANGKAH 1: FAHAMI MASALAH

Gangguan Tumpuan Berbahaya



Dalam modul ini, peserta akan mempelajari:

1. Makna pemanduan dengan perhatian terganggu dan sebab ia berbahaya.
2. Sebab melakukan berbilang tugas semasa memandu adalah mitos.
3. Cara untuk kekal memfokus semasa memandu.

←
1
2
3
4
5
6
→

LANGKAH 2: KETAHUI STATISTIK

Setiap Saat Adalah Penting



Sehingga 80% nahas kenderaan melibatkan suatu faktor hilang tumpuan pemandu.

←
1
2
3
→

LANGKAH 3: TONTON VIDEO



LANGKAH 4: AMBIL KUIZ

Iveco Triumphs at Hotly Contested 2016 Dakar Rally



The new year is off to a superb start for Iveco after winning Eurocargo "International Truck of the Year 2016" and Magelys "International Coach of the Year 2016", Iveco has now triumphed in 2016 Dakar Rally.

Iveco has dominated one of the most competitive Dakar rallies ever with five different truck brands in the Top 10. Iveco's Gerard De Rooy, leader of 'Team PETRONAS De Rooy' mounted the podium after the 2016 edition of the most competitive rally race in the world. His performance over the 13 stages showed once again the pilot's outstanding driving and navigation skills and confirmed the Iveco Powerstar's qualities.

Reliability Demonstrated

"Iveco's vehicles triumph in the 2016 edition of the Dakar," stated Pierre Lahutte, Iveco Brand President, "with a resounding

success and recognition, after the Eurocargo "International Truck of the Year 2016" and Magelys "International Coach of the Year 2016" titles. Iveco puts the excellent reliability of its trucks on the trails of the Dakar rally, enabling the team's outstanding pilots to give their best performance in the race. I would like to thank Gerard De Rooy, Federico Villagra, Anton Van Genugten, Pep Vila and Ales Loprais and their remarkable teams for the determination and drive they have shown."

This is De Rooy's second victory in the Dakar's Truck category. At the end of the competition, the Dutch champion dedicated his victory to his Belgian navigator, Jurgen Damen, who passed away last year.

El Coyote Howls

On the podium in third place, Federico Villagra, "El Coyote", is the revelation of this edition. The Argentinean pilot, in his Iveco Powerstar, was followed by millions of local fans, in a market where Iveco is the leader.

Ton Van Genugten finished fifth in his Trakker. He is the other great surprise of the 2016 Dakar: while he was one of two quick service trucks supporting the Team's lead pilots – De Rooy, Villagra and Loprais – he succeeded in staying ahead of the other leading competitors and crossing the line in fifth place, missing a stage win only because he stopped to support his Team leaders, demonstrating the wonderful team spirit of the Iveco team.

Spaniard Pep Vila, behind the wheel of another Iveco Trakker, took tenth place. The expert Spanish pilot, now at his sixth Dakar with Iveco and fifth with Team De Rooy, fought until the end to finish in the Top Ten.

Iveco Engine Power

The Dakar race has also been a great opportunity for Iveco to highlight the performance of its engines: the Iveco Cursor



13 engines - manufactured in Bourbon Lancy, France and specifically prepared for the race by FPT Industrial at its R&D centre in Arbon, Switzerland – known for their performance and durability, powered Iveco's latest success in the rally.

The 2016 edition with its 9,000km South American route was perfect to showcase the Iveco trucks' versatility and strength.

Final Ranking – Trucks

1. Gerard De Rooy (NLD), Iveco
Co-Pilot: Moi Torrallardona (E)
Mechanic: Darek Rodewald (PI)
2. Mardeev (Rus), Kamaz
3. Federico Villagra (Arg), Iveco
Co-Pilot: Jorge Perez Companc (Arg)
Mechanic: Memi Andres (Arg)
4. Stacey (NLD), Man



5. Ton Van Genugten (NLD), Iveco
Co-Pilot: Anton Van Limpt (NLD)
Mechanic: Peter Van Eerd (NLD)
6. De Baar (NLD), Renault Trucks
7. Nikolaev (Rus), Kamaz
8. Valtr (Cze), Tatra
9. Versluis (NLD), Man
10. Pep Vila (E), Iveco
Co-Pilot: Xavi Colome Roqueta (E)
Mechanic: Marc Torres Sala (E)
11. Ardavichus (Kaz), Tatra
12. Van Del Heuvel (NLD), Scania

Dropped out in Stage 5:

- Ales Loprais (CZ)
Co-Pilot: Ferran Alcayna Marco (E)
Mechanic: Bernardus Der Kinderen (NI) 



Who is that woman behind this truck workshop?



“Your Truck - Our Best Mate” is the motto that makes LAAWRI workshop strive to bringing out the best service for your commercial vehicle.

LAAWRI Workshop held an opening ceremony recently in Shah Alam. There were even a few prime movers lining up in front of the workshop and a supportive cheer from friends and families underlined the great achievement it was.

Asian Trucker took the opportunity to interview the strong woman behind the success to learn more about the story of her long journey in this man’s industry: Siti Nurliyah, 32, known as Puan Liya. Everything started when she decided to work as a clerk in a truck workshop with United-Seino Transportation (M) after failing to get a job that matched her degree.

“Even though I was just a clerk back then, I can say that I managed everything in the workshop except for the actual truck repairs. I had to deal with suppliers, clients, and still needed to understand what were the problems with the trucks from my mechanics. That is how I gained knowledge in this field,” said Puan Liya.

After working for a year and a half as a clerk in the same workshop, the owner of the workshop finished his contract with United-Seino Transportation (M). That was when Liya decided to take over the contract. But at that point Puan Liya did not have any capital to run the workshop. She depended on the trust of people that she had known personally.

“I told my mechanics that I won’t be able to pay their salary for two months. I opened a credit account with my suppliers and I borrowed some amount from United-Seino Transportation (M). These people have put a lot of trust in me,” she said.

“I gained the confidence and the urge to manage this truck workshop when I knew that I had a strong team behind me. A team that is willing to be with me during my ups and downs. Even my family had no idea that I’m running a truck workshop,” she added.





Challenges

It won't be an easy deal to get a role in a male dominated industry especially in the key role. Competitors will always compete no matter who you are. Her biggest challenges at the start were capital, gaining people's trust and to compete for her first contract.

"Once I got the contract with United-Seino Transportation (M), I started the operation of the workshop with what I had: tools and manpower. One of the most important practices that we implement as a workshop principle is to be "transparent". We let our customer or the driver know in detail about the problem discovered. Later we show them "proof" of what my mechanics have changed in any part of the truck or they can as well wait and watch the mechanics," explained Puan Liya.

Even though she is not going to hold the spanner or change the oil, she is at her best in consultation and she knows what is going on with your truck. Today, some five years in the industry, she has dealt with 4 000 trucks coming to her with various problems. Some of her clients even call her "Dr. Truck".

The reason why she is so bold to open a "walk-in workshop" (LAAWRI workshop) is because she also managed to get another new contract from a Korean company. It took her only a month to get the land and

prepare for the launch. "For this year, I'm planning to open another workshop in Penang and Kuantan. As a long term plan, I'm hoping to have a LAAWRI workshop in every state," she smiled.

"My tips for women that want to be successful in a man's industry are, be "friend" with men as in you need to know how to get along with them and let them treat you equally. Always be humble and never shy to ask," she ends her story. 



Controlled traffic runs smoother

Modern technology is crucial when it comes to managing traffic flow.

Another home-grown brand is leading the way in order to give way to traffic, making our trips smoother.

None of us likes to wait at traffic lights. However, they are necessary in order to manage the flow of vehicles at intersections and turns. Many main roads, the arteries of our cities, experience high volumes of traffic during certain times (rush hour) while traffic may flow at lower density during the day. This is when controlled traffic would ease the burden.

TrafficSens Controller is an advanced version of actuated control that takes advantage of advance information about vehicle trajectories to achieve more effective and efficient signal timings. As a result, the vehicles spend less time passing through the network than they would if a fixed cycle-length control strategy were employed. Because the vehicle flows are observable, through field sensors, it is possible to generate traffic-responsive stage sequences and switching times that minimize delays. The distributed intelligence at the intersections is used in conjunction with shared information about vehicle movements. It is prepared to make use of either wired or wireless communications technologies.

The signal timing evolves in a traffic-dependant responsive, intelligent manner; where the signals talk to one another and share data about the vehicle



flows as well as the signal indications being provided (greens, stage sequences, etc.). By doing so, they individually and collectively find switching sequences and times that minimize the delay for all vehicles. By doing this, stopping is reduced as well as trip times. Vehicles are serviced at the intersections expeditiously when they arrive. The signals prepare to provide greens in a logical, traffic responsive sequence. Minimum delay trajectories are created by having greens be provided for the oncoming vehicles just before they arrive or as soon thereafter as possible.

TrafficSens System (M) Sdn. Bhd. is a fast growing Malaysian company with a mission towards providing intelligent and advanced traffic management systems. The company has been offering their system for some five years by now and close to 200 units of their controllers have been installed. Customers include DBKL, Johor Baru and Negeri Sembilan.

The system can be installed within two weeks, given that the civil side of the road construction is ready to take the system. To gather the data of the traffic volume,

induction loops or wireless sensors are used. Customers will have access to the control panel and can monitor the performance via smartphones. If the thought of a failure is a concern, then road users can be rest assured that safety is the prime concern of the programming. Should the controller malfunction, the traffic lights will go to their default setting of flashing yellow lights. **F**



automechanika

DUBAI

The largest international automotive aftermarket trade exhibition in the wider Middle East

Arriving faster:
8 – 10 May, 2016
ONE MONTH EARLIER

**Gear up for business growth
across the wider Middle East.**

Welcome to Automechanika Dubai.

A place to strike business deals, discover advanced technology and explore new markets, it's where supply and demand come together.

In 2015, **1,882** exhibitors and **30,365** visitors found out just how much difference attending Automechanika Dubai can make.

Make a difference to your own business. Register online today at www.automechanikaDubai.com/ATB



messe frankfurt

ASIAN TRUCKER DRIVERS CLUB

UPDATE



PREMIUM SPONSOR:



Shell
RIMULA
Heavy Duty Diesel Engine Oil



Supercool
Engineered For Safety
by GIB

KIT LOONG
COMMERCIAL TYRE

FleetSafe in Malaysia

The FleetSafe online driver safety programme is being used by Fonterra in Asia and the Middle East, with over 470 drivers participating across 9 countries in 6 languages.

In Malaysia alone there are a total of 280 drivers in the language variations of Malay, English and Chinese. This is part of Fonterra's continued safety awareness programme to help its people reduce the risks of being involved in an accident whilst driving on the road. The programme is designed to increase drivers driving safety awareness and to ensure that they go home safe every day.

The online e-learning driver safety training programme is the most advanced system of it's kind in the world. The programme is not trying to teach anyone to drive. Instead, the focus is on reinforcing the need to drive safely and to increase awareness. The modules are designed to only take 15-20 minutes to complete, saving time and keeping employees productive with their daily activities. Modules can be undertaken on mobile phones or tablets and are spread over a period of time, not all at once.

The programme routinely sees a 30% reduction in collisions coupled with a reduction in the severity of their collisions. All modules utilise real life video footage, which leads to better retention rates by drivers and are individually customised with local content, footage and languages. The system automatically corresponds via email with drivers that have overdue lessons and this subtle reminder significantly improves compliance.

Malaysia Special Offer

To start making the year 2016 a safer one for everybody on the roads, Asian Trucker Drivers Club is offering the following modules as introduction specials:

Hazard Perception Evaluation with prescribed Defensive Driver Training Modules = S\$ 190 per person

6 Targeted Defensive Driver Training Modules (2 & 4 wheel powered vehicles) = S\$ 200 per person

Malaysia Special 3 Targeted Defensive Driver Training Modules = S\$ 75 per person

Club activities start with a record attendance

Fulfilling the request from truckers that missed our previous workshop, we organised the highly insightful workshop on tyre safety and management again and saw a record number of attendees.



This was our fourth time organizing the tyre safety and management workshop, collaborating with Goodway Rubber Industries Sdn. Bhd in Nilai. We had around 28 participants including seven new members that registered on the workshop day itself.

It is the same workshop as what we have done previously. The half day meeting comprised two sessions which are the theory session and the factory tour. For events like this, we are more than happy to welcome anyone even if you are not a member of Asian Trucker Driver Club and we encourage you to send your colleagues or attend yourself.

We will have more events lining up for this year. Like our Facebook account for more updates or register to become a member of Asian Trucker Driver Club.

Warm up first before the day gets productive!

It is more than just driving to the destination when you are driving a rental truck for relocations.



Brunch with a trucker, why not? Asian Trucker is more than happy to sit with Mr Saiful Kamal, 36, for an informal interview about his trucking adventures.

AT: Maybe you can tell us briefly about your experience as a truck driver?

SK: My first trucking career started in courier service back in 2007. In 2009, I had the desire to drive the so called "big trucks", therefore I got a job to drive a cargo truck for a logistic company for six years. I have my own moments, driving long haul, outstation, and I basically know how it felt to live on the road, in a truck.

AT: Why do you decide to return to driving a light duty truck, which is your current job now?

SK: Well, it was all fun at first to travel. But I realised that when you got the long haul trips you may reach the point where you spent too much time on the road and forgot to spend time with your family and friends. I missed a lot of important occasions too. I have come to my sense where I thought of how should I balance it and still do the work that I love. Thus, from the long haul trucker, I changed yet again to be daily trucker, a driver for truck rental.

AT: How can you describe working as a rental truck driver?

SK: I would say a productive day is a promise and it requires more skills. Usually most of my customers need to rent a truck for relocation. To do relocation, my job is not only to focus on

driving the truck, but I also need to carry the goods in and out of the truck. Extra work and care is needed when the job involves stairs, carrying heavy goods and valuable goods.

AT: What are your daily good practice in order to deliver your job completely?

SK: Getting your job done is not enough for me, but getting the job done with customer satisfaction is my main concern. My main focus is doing my job are time, with zero complaints and I try to keep a high level of communication. I always make sure to give notification half an hour before reaching the destination or to inform the customer earlier if there is traffic issue. Handling all the goods with care and safety either while driving the truck or carrying the items is crucial as these goods are valuable, either in terms of money or sentimental value. Being a rental truck driver involves more communication. First things first, you should always greet customers with a smile and make sure you receive all the information clearly to avoid any miscommunication. Never complain if you get an unexpected work load.

Mr Saiful was together with his boss, Mr Sahbri Salleh during the interview. According to Mr Sahbri, he did a test on all his drivers to ensure the service that they deliver is in accordance to the guidelines that he has taught. He believes that, if he nourishes and cares towards all drivers, they will eventually take good care of customers. **f**



Bersedia untuk hari yang lebih produktif!

*Pemandu lori sewa
bertanggungjawab lebih
dari sekadar memandu*

Kali ini, sarapan pagi saya ditemani oleh seorang pemandu lori, kenapa tidak? Asian Trucker berbesar hati dapat meluangkan sedikit masa bersama Encik Saiful, 36 untuk temubual yang agak santai berkenaan tugas harian beliau.

AT: Mungkin Encik Saiful boleh ceritakan serba sedikit tentang pengalaman memandu trak.

SK : Kerjaya saya bermula pada tahun 2007 dengan menjadi pemandu untuk perkhidmatan kurier. Pada tahun 2009, saya berkecimpung di dalam industri logistik sebagai pemandu trak kargo selama enam tahun. Tidak dinafikan, memandu trak kargo sangat membolehkan terutamanya apabila mendapat penghantaran luar Malaysia. Selama enam tahun, jalan raya dan trak adalah rumah kedua saya.

AT: Apakah yang membuatkan Encik Saiful beralih kepada lori sewa?

SK: Pengalaman yang baru memang menyeronokkan pada awalnya tetapi pada satu tahap, saya menyedari, masa saya terlalu banyak dihabiskan di atas jalan raya. Saya tiada masa untuk keluarga dan kawan-kawan. Terlepas beberapa majlis penting atas alasan kerja. Kini, dengan bekerja sebagai pemandu lori sewa, saya masih boleh memandu lori dan membahagi masa dengan secukupnya bersama keluarga.

AT: Boleh Encik Saiful terangkan secara ringkas tentang pekerjaan sebagai pemandu lori sewa.

SK: Apa yang saya boleh katakan, menjadi seorang pemandu lori sewa adalah satu pekerjaan yang sangat aktif dan

memerlukan lebih kemahiran. Kebanyakan pelanggan saya yang ingin menggunakan perkhidmatan lori sewa, adalah untuk tujuan memindah barang dari satu destinasi ke satu destinasi yang lain. Bagi kerja pemindahan barang, saya bukan hanya perlu fokus kepada pemanduan lori tetapi juga apabila saya perlu mengangkat barang keluar masuk lori. Kerja mengangkat barang perlu dilakukan dengan berhati-hati terutama jika melibatkan tangga, barang yang berat dan berharga.

AT: Bagaimanakah Encik Saiful memastikan tanggungjawab yang diberi dijalankan dengan sempurna?

SK: Memastikan setiap tugas selesai adalah tidak cukup bagi saya, tetapi setiap tugas perlu selesai dengan kepuasan dari pelanggan. Perkara yang sentiasa saya utamakan ialah menepati masa, tiada rungutan dari pelanggan dan saya akan cuba berkomunikasi secara jelas. Saya akan sentiasa memaklumkan kepada pelanggan setengah jam sebelum tiba ke destinasi atau jika ada masalah kesesakan jalan raya. Barang yang dipindahkan adalah tanggungjawab kita untuk menjaganya dengan cermat. Biasanya saya akan memberikan salam mesra terlebih dahulu kepada pelanggan dan memastikan maklumat berkaitan pindahan adalah tepat.

Encik Saiful bersama bos beliau, Encik Sahbri ketika ditemubual. Menurut Encik Sahbri, dia pernah menguji kesemua pemandu lorinya supaya mereka member perkhidmatan seperti garis panduan yang beliau berikan. Beliau percaya bahawa jika kita menjaga para pekerja kita, mereka secara tidak langsung akan menjaga perniagaan kita. **F**



HAPPY CHINESE
NEW YEAR

恭喜
发财





One-Stop-Shopping!



Spare parts for commercial vehicles



DT® Spare Parts – Genuine Quality. Durable Trust.

www.dt-spareparts.com

DT® Spare Parts offers a complete product range for commercial vehicles with all required spare parts in guaranteed quality. Ask your local dealer for DT® Spare Parts products and catalogues.

The latest news about DT® Spare Parts brand products is available in the regularly "Parts info" newsletters.

Get more information and subscribe to the newsletter:
<http://newsletter.dt-spareparts.com>

dt® – a trademark of DIESEL TECHNIC AG, Germany – www.dieselitechnik.com

Subscribe to the Newsletter
and stay up-to-date



www.dt-web.tv



Year manufactured	1924
Manufacturer	Tokyo Ishikawajima Shipbuilding and Engineering
Vehicle name / Manufacture	Vehicle name: Wolseley Truck
	Model name: Wolseley Model CP
	Company name: Tokyo Ishikawajima Shipbuilding & Engineering Co., Ltd.
	Year manufactured: 1924
	Designed by: Wolseley Motor Company (UK)
	Vehicle type/usage: Truck
	Location of actual vehicle/replica: Isuzu Motors Limited
Model / Weight	Style: Bonnet type truck
	Number of doors: 2
	Passenger capacity: 2
Body / Size	Structure: Wooden cab
	Bumpers: None
	Step: Provided
	Overall length: 5410 mm
	Overall width: 1830 mm
	Overall height: 2250 mm

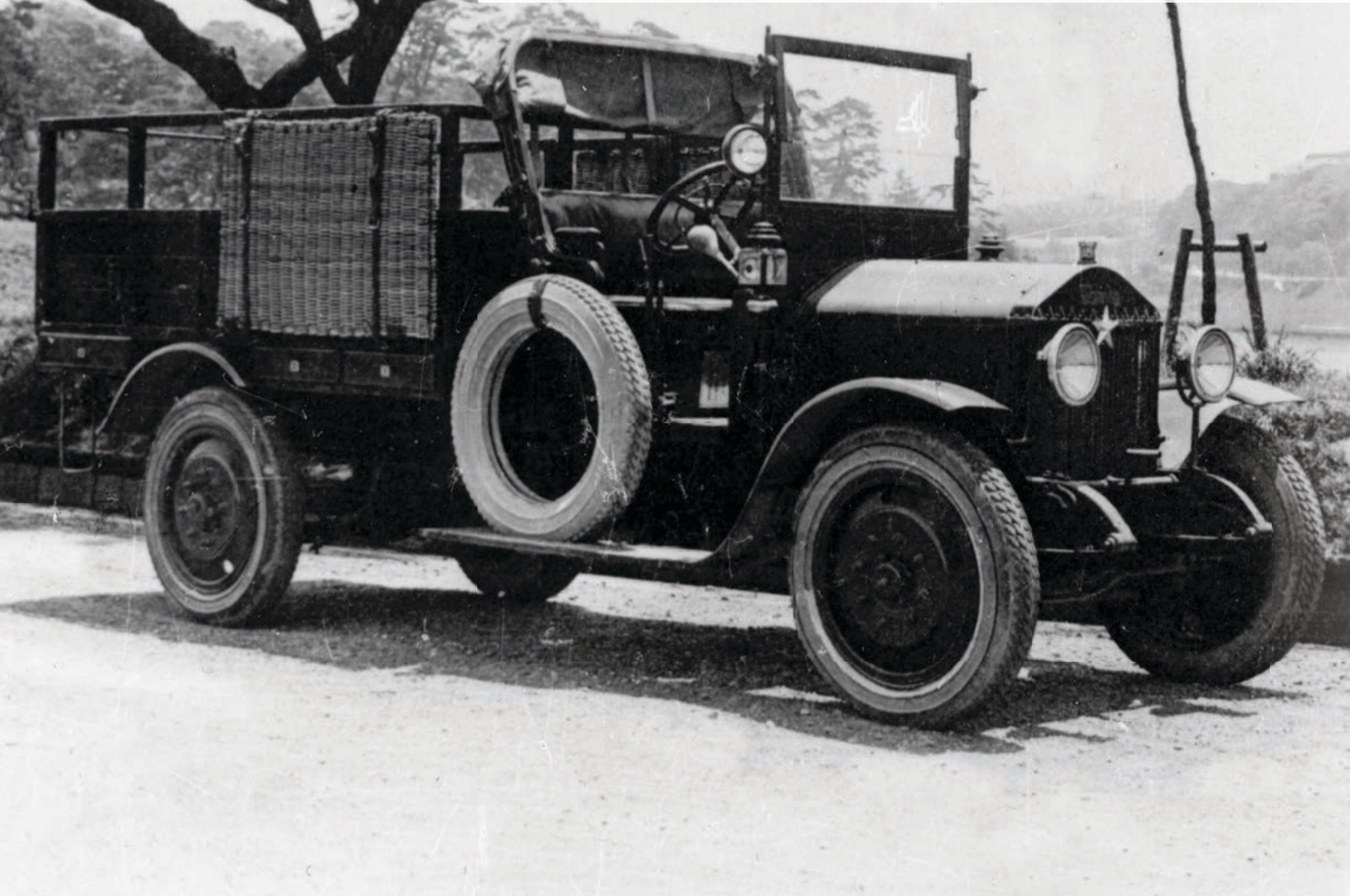

Bringing back Memories - Isuzu celebrates 100 years

In 1924, Tokyo Ishikawajima Shipbuilding and Engineering, a forerunner of Isuzu Motors, produced the 1.5-ton CP truck in Japan through a tie-up with Britain's Wolseley Motors. The vehicle played a pioneering role in the establishment of a domestic automobile industry in Japan in the mid-1920s.

The preserved vehicle was returned to Isuzu from the National Science Museum in 1991 and was completely restored. It is now maintained in full operating order and is on display in the entrance hall of the Isuzu headquarters. 

Body / Axle / Driving / Others	Tire size: 36x6
	Frame: U-type section steel sheet ladder type
	Front axle: I type reverse Elliot, 1/2 leaf
	Rear axle: 3/4 floating type, 1/2 leaf
	Wheelbase: 3660 mm
	Front tread x rear tread: 1560x1560 mm
	Vehicle height adjustment: None
	Steering: Worm and sector type
	Dampers: None
	Stabilizer: None
Driving stability devices: None	
Engine / Size / Power	Engine name: CP type gasoline engine
	Cooling/cylinder arrangement: Water-cooled/inline 4-cylinder
	Valve train: SV
	Carburetor: Stromberg type
	Bore x stroke: 90x121 mm
	Displacement: 3100 cc
	Ignition system: magneto type
	Max. power/r.p.m: 26 hp
	Supercharger: None
	Variable ignition system: Manual ignition timing
Fuel tank capacity: 75 L	
Hybrid	Hybrid System type: None
Drive-train	Transmission: MT4
	Drive system: FR 4x2



WABCO Signs Long-Term Agreement with Dongfeng in China

JBTC EXPO 2016

JBTC EXPO (Johor Bus, Truck & Components Exhibition) is formed by the Johor Sand & Granite Lorry Operators' Association. It is to provide another type of service and platform to serve the members as well as to create networking opportunities with the transportation and logistics industries. It is ideal for market players who would like to penetrate into Southern Malaysia's market, especially in the recent booming projects such as Melaka Second Islands Development and Johor Iskandar Development.

With the great support from government agencies, trade and industry associations, organisers believe that JBTC EXPO will be able to enhance the logistic supplies chain with better networking and connection with the local industry authorities, trade organizations and associations of southern Malaysia - MELAKA and Johor Bahru, Johor. JBTC EXPO will also promote road safety awareness during the three days event, especially during the Safety and Charity Annual Dinner which will be held on 13th August 2016 (Saturday). Ministry of Transport Malaysia (MOT), Land Public Transport Commission (SPAD), Jabatan Keselamatan Jalan Raya Malaysia (JKJR), Malaysia Institute of Road Research (MIROS), Malaysia Automotive Institute (MAI) & PUSPAKOM Sdn. Bhd. will be invited to this event for the conference, dialogue and opinion sharing with the industries' operators and associations and members.

Through this event, the organisers hope to contribute to the promotion of road safety for Malaysia in order to reduce the high accident ratio through meaningful activities and events.

EXPO@Danga City Mall, Johor Bahru
12th - 14th August (Friday - Sunday)

Safety & Charity Annual Dinner
Restoran Pekin Sutera
No.1, lalan Sutera Tanjung 8/4,
Sutera Utama Biz Centre,
Taman Sutera Utama,
81300 Skudai, Johor
13th August 2016 (Saturday, 7:00 pm)



WABCO has entered into a new long-term supply agreement with Dongfeng Liuzhou Motor Company (DFLQ), an existing customer and one of the largest truck manufacturers in China.

WABCO's new business involves braking solutions, including anti-lock braking (ABS) and electronic braking systems (EBS); as well as ESCsmart™ electronic stability control (ESC) and OptiRide™ electronically controlled air suspension (ECAS), among other advanced vehicle safety and efficiency technologies. WABCO begins series delivery immediately to supply DFLQ's current medium- and heavy-duty truck platforms. DFLQ produces trucks for the Chinese market and for the export market, including South East Asia, Africa, Middle East and South America.

"We are strategically transforming our range of medium- and heavy-duty trucks to be more competitive for long-haul transport and logistics," said Cheng Daoran, General Manager, Dongfeng Liuzhou Motor Company. "We are leveraging WABCO's leadership in safety and efficiency technologies to improve vehicle performance. We also benefit from WABCO's advanced maturity in globalization that results in unmatched

local connectivity and service, including local engineering and manufacturing at world-class levels."

In addition, WABCO has recently received three prestigious supplier awards from DFLQ, marking unprecedented recognition for WABCO's outstanding performance. DFLQ granted WABCO awards for superlative contributions and commitment during 2015 in three categories, including best quality, supplier excellence and strategic supplier. DFLQ honored WABCO among a distinguished group of around 1,000 suppliers.

"Winning this new business further demonstrates how WABCO creates a world of difference for customers through technology leadership, global engineering and manufacturing, and excellence in execution," said Yu. "WABCO's locally minded connectivity with customers makes a big difference in successfully anticipating and creatively seizing market opportunities.

DHL Extends TAPA Certification Stronghold in Asia Pacific

DHL Express has recorded a new milestone in its continuous drive to offer superior security and service levels in end-to-end supply chain solutions in Asia Pacific. The Transported Asset Protection Association (TAPA) Asia recognized DHL Express for having the most Freight Security Requirement (FSR) sites in Asia Pacific.

The company's North Operating Center in Beijing is the 100th facility within the DHL Express network in Asia Pacific to be awarded the prestigious TAPA 'FSR' security certification. It is also the company's 22nd facility in China to be TAPA 'A' certified.

The internationally-recognized TAPA certification is a highly sought-after logistics security accreditation and certification, and considered to be one of the industry's most rigorous independent certification. Facilities are certified after a detailed audit conducted by independent TAPA-trained auditors on areas such as the way high value goods are handled, warehoused and transported as they move throughout the global supply chain.

"Obtaining TAPA certification for our facilities is critical to ensuring the safety and security of our facilities and shipments as this is an increasing concern of our customers. With Asia Pacific accounting for 25% of total international express traffic, the second largest after Europe, it is critical that we have a robust system to safeguard the integrity of shipments that we handle. This achievement fortifies our position as the industry leader in Asia Pacific," said Ken Lee, CEO, Asia Pacific, DHL Express.

Tony Lugg, Chairman of TAPA Asia, said, "DHL has consistently and effectively demonstrated their efforts to integrate TAPA standards in their global network. Their commendable resolve echoes TAPA's mission of enhancing the security and integrity of the global supply chain by protecting high value goods from risks and contributing to sustainable economic growth."



Mercedes-Benz Malaysia Commercial Vehicles post sales of 2,623 units



Mercedes-Benz Malaysia continues its successful run, recording sales of 2,623 commercial vehicles in 2015, a 5.5 per cent increase from 2014.

In 2015, as the producer of Mercedes-Benz Commercial Vehicles and FUSO trucks, Mercedes-Benz Malaysia delivered to customers a respective total of 193 units and 2,430 units. In doing so, Mercedes-Benz Malaysia has effectively increased its market share in Malaysia for both European and Asian truck segments.

Reviewing its 2015 performance, Mercedes-Benz Malaysia Commercial Vehicles, Vice President, Albert Yee said, "Amidst challenging market conditions, Mercedes-Benz Malaysia Commercial Vehicles has increased sales, market share, launched a new truck series, and simultaneously achieved significant milestones at our Pekan production plant. We concluded 2015 on a high note, securing several fleet deals with long-standing customers. Their belief in Mercedes-Benz Commercial Vehicles and FUSO Trucks are a testament to the hallmark quality and service that we deliver. Customers are at the heart of our business and as a producer of leading commercial vehicle brands, we aim to meet their need for quality vehicles."

In 2015, Mercedes-Benz Malaysia extended its FUSO product portfolio with the launch of new variants, the FM and FN series, in October. The FM and FN series is a succession to its predecessors which was launched in 2009. The new variants feature a complete new cabin design and new engine with more safety features such as ABS.



The cold truth about Knorr-Bremse: Testing Brakes in Arjeplog

Each November, some of the brightest minds in the automotive world set up tent in the far north of Europe to push the envelope of modern vehicle design during the grueling winter season.

At a first glance, Arjeplog, a small town in the north of Sweden just shy of the Arctic Circle, may not be the ideal candidate for a winter destination. While there is plenty of snow and ice, there is hardly any skiing; and with less than 3,000 people spread over almost 15,000km², the nightlife is negligible too. But if you plan on testing classified technology in peaceful seclusion, away from a curious crowd, it may be just the right place to settle. And, that's exactly what Europe's automotive elite did.

Since a first 'reconnaissance party' arrived here in the 1970s – searching for a quiet and sedate place to put technology to the test that wasn't even officially invented yet – Arjeplog has become the mecca of European automotive testing. Many a prototype has since been spotted on the snowy Silvervägen, Arjeplog's main arterial road, and the town developed a whole industry catering to the annual incursion from the south. One of the first businesses to settle in Arjeplog, following the likes of Bosch and Daimler, was German braking specialist Knorr-Bremse. Dr Eduard Gerum, the company's retired head of engineering has some comments to share.

"We started with hardly anything but have since built a highly sophisticated, company owned test lab up here. It's amazing to see how far we've come in such a short amount of time, and I am sure many of the technologies we now take for granted in the heavy vehicle sphere, like ABS, would not be as efficient as they are if it wasn't for Arjeplog," he says. From a simple corrugated iron shed in the 1970s, the Knorr-Bremse test center has grown into a high-tech facility with an integrated heavy vehicle workshop, offices with high-speed Internet connection and, most importantly, a company-owned test track. As an internationally acclaimed OES, it is here where the company does much of the finetuning for new truck and trailer braking technology before it goes into serial production.

"From ABS to more complex technology like EBS and ESP/RSP, we lay much of the development groundwork during those three or four months we spend up here," says Dr Gerum, struggling to hide his excitement about the opportunities Knorr-Bremse's northernmost outpost has opened up for the brand. "Most of the work we do here is adjusting our equipment to a new truck and trailer model that is about to be released, so we do a lot of driving here to cover all our bases." The Knorr-Bremse test facility comprises of a land test track just next to the actual workshop, as well as a second area on a frozen lake down the road. At the heart of the land test track is a long straight, one half of which is heated concrete and one polished ice. "It's here where we separate the wheat from the chaff," says Dr. Gerum.

75 Years of MANN+HUMMEL

From a small filter plant to a global market leader in filtration: Ludwigsburg-based automotive supplier MANN+HUMMEL will celebrate its 75th anniversary in 2016. Founded under difficult conditions during the Second World War, the family-led company has grown to become the world's biggest manufacturer of oil, air, and gasoline filters, employing around 16,000 people at 60 locations on five continents.

DT Spare Parts - Gear shift knobs for trucks and buses



Guaranteed quality has made the brand DT Spare Parts the leading brand in the international Independent Aftermarket for commercial vehicles. The complete range includes all required spare parts for trucks, trailers and buses, including all standard gear shift knobs.

Gear shift knobs are used to operate the manual or automatic gears in vehicles of all kinds. They are composed of an abrasion-resistant plastic, pleasant to the touch.

Models for modern vehicles can include an integrated switching function for additional gear reduction of the primary gear and the range gear. This switching function can be electrical by means of switches or hydraulic with valves.

In modern trucks and buses, the conventional gear shift lever is replaced by a joystick on the transmission tunnel. There are different systems. Electronics which record the various driving parameters, such as speed and engine rotational speed, give the driver a shift recommendation via the display on the instrument panel.

If the driver accepts the recommended gear, he only needs to press the clutch. The result is a measurable fuel saving.

A further version is the electro-pneumatic shift. The choice of gear without shift recommendation is always performed by tapping the knob forwards or backwards.

Special functions, such as the rocking free or maneuvering programme, can be accessed directly via the shift paddles on the instrument panel.

These modern gear shifts are installed in both mechanical as well as automatic gearboxes. They facilitate shifting considerably and lead to a fuel-saving driving style.



HARDOX[®]
WEAR PLATE

NOT ALL BODIES ARE CREATED EQUAL



Equipment and wear parts made with HARDOX wear plate is your guarantee of outstanding resistance to impact and extreme abrasion. That translates to maximum service life, less risk of breakdowns and enhanced productivity.

Because you ask a lot of your equipment, get the wear plate preferred around the world - HARDOX, the number one choice in abrasion resistant steels.

Its hardness, strength and toughness make it unlike any other steel on earth. It's the highest industry standard for applications such as excavators, tipper bodies, conveyors, crushers, mixers, barges and more.

SSAB

Office & Stocks

Singapore : +65 6863 1622

Malaysia : +6019 754 3928

E-mail: Singapore@ssab.com

www.ssab.com

www.hardox.com

SSAB

SSAB is a Nordic and US-based steel company. SSAB offers value added products and services developed in close cooperation with its customers to create a stronger, lighter and more sustainable world. SSAB has employees in over 50 countries. SSAB has production facilities in Sweden, Finland and the US. SSAB is listed on the NASDAQ OMX Nordic Exchange in Stockholm and has a secondary listing on the NASDAQ OMX in Helsinki.



Driverless Dreams

Recently Singapore announced that the Island state will make a push to introduce driverless vehicles. Starting with smaller buses in tourist attractions, the purpose is to gather data in order to scale the project up. Tests with truck platooning have also seen some very interesting results in Europe. Should all truckers now be in a panic over the prospect of losing their jobs?

The Eye in the Truck

I think not. For a start, there is still a lot of work to be done before the truly driverless truck can be deployed. Even though the technology has come a long way, the vehicles on trial in Singapore are still having a “driver” on board to be able to intervene in case something happens. And while the truck might be driverless, the vehicle will still need supporting infrastructure. Depending on how the vehicle is being guided, one would need either fantastic GPS coverage and accuracy or clearly marked lanes for the “eye in the truck” to be able to pilot along the street.

So, while all this is being set up, the need for the traditional driver is still there and growing. Even when the technology is ready, there would still be a transition period as it would be unlikely that fleet owners would switch to driverless vehicles overnight. At least not those who have more than a handful of trucks as the investment needs to be carefully planned and executed over time. And if you think about the effort needed for a small place like Singapore, then imagine what it would take to get a country like Thailand or Vietnam prepared for this step.

Not Fool Proof

Another aspect yet to be fully addressed is that of the insurance for the vehicles. While the driverless tractor is reducing or eliminating the possibility of human error, there is always the possibility that electronics

or software might fail. Please put your hands up if you are using a PC and have seen a “blue screen”. Who will be responsible in such a case when a driverless truck has a systems melt down and causes an accident? Do we need to have maintenance protocols for software too in order to shift the responsibility from the OEM to the vehicle operator?

Long distance transportation is another issue that needs to be addressed. Now that we have the ASEAN Economic Community in place, it is possible to ply through many countries without restrictions. At least in theory. Here again there will be obstacles to overcome before the truly driverless truck can be used. For example countries will need to agree on providing the same infrastructure for driverless trucks. Currently, paperwork is still needed for the passage between countries. Certainly, that too could be done online with a system that would render the pilot unemployed, but again, this may also be a long way to go. Meanwhile, we still have issues to address when it comes to long haul operations. Issues that might be best solved by humans as they may be more responsive and pragmatic.

More Opportunities

Ultimately, we will see a shift to driverless trucks. This may be a trend that cannot be stopped. However, there will still be people needed around them. Maybe not as drivers, but as software developers, test drivers and mechanics. The driverless truck may also be an opportunity for more people to start their own business. While the truck is driving, the owner can ride along and handle paperwork, making the cab his rolling office. It may be premature to start retraining your drivers now, but someday the future vision of the automated vehicle will be reality. And I am sure that many of us will still be around to see it. **F**



SHELL FUELSAVE DIESEL EURO 5 **DESIGNED TO LAST LONGER PER TANK***

At Shell, we understand Malaysian motorists' need for high quality fuels. That's why we're introducing Shell FuelSave Diesel Euro 5. Our efficient diesel with Active Efficiency Ingredients and ultra low sulphur is specially designed to help improve fuel economy from the first tank.*

*Comparison between a standard diesel and that same standard diesel (of the same bio-content) containing our fuel economy formula. Savings may vary according to vehicle, driving conditions, and driving style. Suitable for all diesel engines including modern diesel engines which require low sulphur diesel. Available at selected Shell stations. Visit www.shell.com.my/dieseuro5 for more details.

Shell
FuelSave
Diesel Euro 5



All New FUSO FM/FN Series

The perfect combination of power & efficiency



Model	Engine Output	Drive Configuration
FM65FJ	240ps - Common Rail System	4 x 2
FM65FN	270ps - Common Rail System	4 x 2
FNG2FM	270ps - Common Rail System	6 x 4



For Enquiry,
Scan This

▶ **Durable Chassis**
▶ **Full Air Brake**

Distributor of:



Mercedes-Benz



FUSO

*Please visit www.mitsubishi-fuso.com.my for more information and terms & conditions.

CUSTOMER CARE
1-800-88-1133

Mercedes-Benz Malaysia